


# Installation, Operation, and Maintenance manual for the EMT 10T F1, 10/4, and 10/4T embroidery peripherals



- Single- and four-head tubular embroidery peripherals
- 

Part Number 15338, Revision D

**Melco**   
Embroidery Systems  
A Saurer Group Company

1575 West 124th Avenue  
Denver, Colorado 80234  
United States of America  
E-mail: editor@melco.com  
Please visit our website at:  
www.melco.com

© Copyright 2000 by Melco Embroidery Systems

ALL RIGHTS RESERVED No part of this publication may be reproduced, stored in a retrieval system, or transmitted in any form or by any means (electronic, mechanical, photocopying, recording, or otherwise) without prior written approval of Melco Embroidery Systems. Melco reserves the right to revise this publication and to make changes in it at any time without obligation of Melco to notify any person or organization of such revisions or changes.

All precautions have been taken to avoid errors or misrepresentations of facts, equipment, or products. However, Melco does not assume any liability to any party for loss or damage caused by errors or omissions.

All trademarks and trade names contained within this publication are the property of their respective owners.

Printed in the United States of America

Revision A, April 2000  
Revision B, August 2000  
Revision C, October 2000  
Revision D, November 2000

# Table of Contents

---

## General

---

EMT 10T F1 Specifications	iv
EMT 10/4 and 10/4T Specifications	v
Explanation of Symbols	vi

## 1. Installation

---

Unpacking	1-1
Moving the Peripheral	1-4
Cart Assembly (EMT 10T F1 only)	1-6
Installing the Tabletop (EMT 10/4 and 10/4T only)	1-8
Connecting cables	1-10
First Powerup	1-13
Support Brackets (EMT 10/4 and 10/4T only)	1-15

## 2. Operation

---

Hazards of Operation	2-2
Threading	2-4
Tensions	2-5
Keypad	2-6
The Menus	2-8
Main Operator Menu	2-8
Disk Directory Menu	2-8
Design Menu	2-8
Color Menu	2-8
Run Design Menu	2-8
Function Menu	2-9
Options Menu	2-10
Frame Menu	2-12
Reset Menu	2-12
Service/Maintenance Menu	2-12
Head Timing Menu	2-13
4 Hr Lubrication Menu	2-14
8 Hr Lubrication Menu	2-14
40 Hr Lubrication Menu	2-14
80 Hr Lubrication Menu	2-14
480 Hr Lubrication Menu	2-14
2100 Hr Lubrication Menu	2-14

Configuration Menu	2-15
Move Function Menu	2-17
Define Custom Hoop	2-18
Test Mode	2-18
Diagnostics Menu	2-19
Disk Drive	2-20
Loading a Design	2-21
Hooping	2-22
Quick Start	2-23
Set Home	2-23
Select Hoop	2-23
Select Orientation	2-23
Center Hoop	2-23
Attach Hoop	2-24
Select a Design	2-26
Color Menu	2-26
Run Menu	2-26
Trace the Design	2-26
Start Embroidering	2-27
Embroidery Speed	2-27
Idle Display	2-27

### **3. Accessories**

---

Standard Cap Frame	3-1
Wide-Angle Cap Frame	3-6
Sash Frame	3-17
Spider Hoops	3-18
Lamps	3-20
Bobbin Winder	3-21

### **4. Operator Maintenance**

---

Installing a Needle	4-1
Cleaning	4-2
Lubrication	4-3
Time to oil hook	4-3
8 Hr Maintenance	4-4
40 Hr Lubrication Menu	4-5
80 Hr Maintenance	4-5
480 Hr Maintenance	4-9
2100 Hr Maintenance	4-10
Replacement Parts	4-12

## **5. Troubleshooting Guide**

---

Thread Breakage	5-1
Skipped Stitches	5-2
Needle Breaks	5-2
Loose Stitches	5-3

## **6. Error Messages**

---

## **7. Glossary of Embroidery Terms**

---

## **Index**

---

## **Quick Reference Guides**

---

# Single-Head Embroidery Peripheral EMT 10T F1 Specifications

---

## Maximum embroidery speed

1200 stitches per minute

## Number of heads

1

## Needles per head

10

## Dimensions

114cm W x 92cm H x 89cm D  
45" W x 36" H x 35" D

## Weight

97.7kg  
215 lbs

## Shipping weight

136.4kg  
300 lbs

## Power consumption

100 W

## Noise level and test conditions

Equivalent continuous A weighted sound pressure level at 1 meter from the floor is 78db.

The peak C weighted instantaneous sound pressure level is 77db.

The noise level was measured sewing a test design at 800 spm.

## Recommended power conditioning equipment

LC 1800 Line stabilizer (available from Accessory Resource Corporation)

## Embroidering field size

28 x 50cm (11 x 19.7") with the Sash Frame  
26 x 41cm (10.25 x 16.15") with a tubular frame

## Options

Cap frame option  
Wide-angle cap frame option  
Sash frame option  
Bobbin winder option  
Cart option

## Compatibility

EDS III and EDS IV

## Intended use

The EMT 10T F1 is designed to embroider on textile products which are placed easily in a Melco embroidery hoop. The machine should not be used on thick leather, wood, plastic, or other dense material.

For heavier goods it is recommended to decrease the maximum sewing speed by at least 200 spm (switch the turbo mode off in the "Options Menu").

The EMT 10T is designed to embroider using tubular and flat hoops, cap frames, and the sash frame.

# Multi-Head Embroidery Peripheral EMT 10/4 and 10/4T Specifications

---

## Maximum embroidery speed

1000 stitches per minute

## Number of Heads

4

## Number of needles

10 per sewing head

## Dimensions

244cm W x 152cm H x 88cm D  
96" W x 60" H x 34.5" D

## Weight

332kg  
730 lbs

## Shipping weight

355kg  
780 lbs

## Power consumption

400 W

## Noise level and test conditions

Equivalent continuous A weighted sound pressure level at 1 meter from the floor is 84db.

The peak C weighted instantaneous sound pressure level is 84db.

The noise level was measured sewing a test design at 850 spm.

## Recommended power conditioning equipment

LC 1800 Line stabilizer (available from Accessory Resource Corporation)

## Embroidering field size

28 x 40.6cm (11.02 x 16.0") with the Sash Frame  
26 x 41cm (10.25 x 16.15") with a tubular frame

## Options

Cap frame option  
Wide-angle cap frame option  
Sash frame option

## Compatibility

EDS III and EDS IV

## Intended use

The EMT 10/4 and 10/4T are designed to embroider on textile products which are placed easily in a Melco embroidery hoop. The machine should not be used on thick leather, wood, plastic, or other dense material.

The EMT 10/4 and 10/4T are designed to embroider using tubular and flat hoops, cap frames, and the sash frame.

## Explanation of Symbols

---



Caution!



Indicates a machine component will move. Keep clear!



Shock hazard. No user replaceable parts behind this label. Do not open!



Pinch point, Keep clear!



Pinch point, Keep clear!



Pinch points, Keep clear!



Needle pinch point, Keep clear!



Use a forklift.



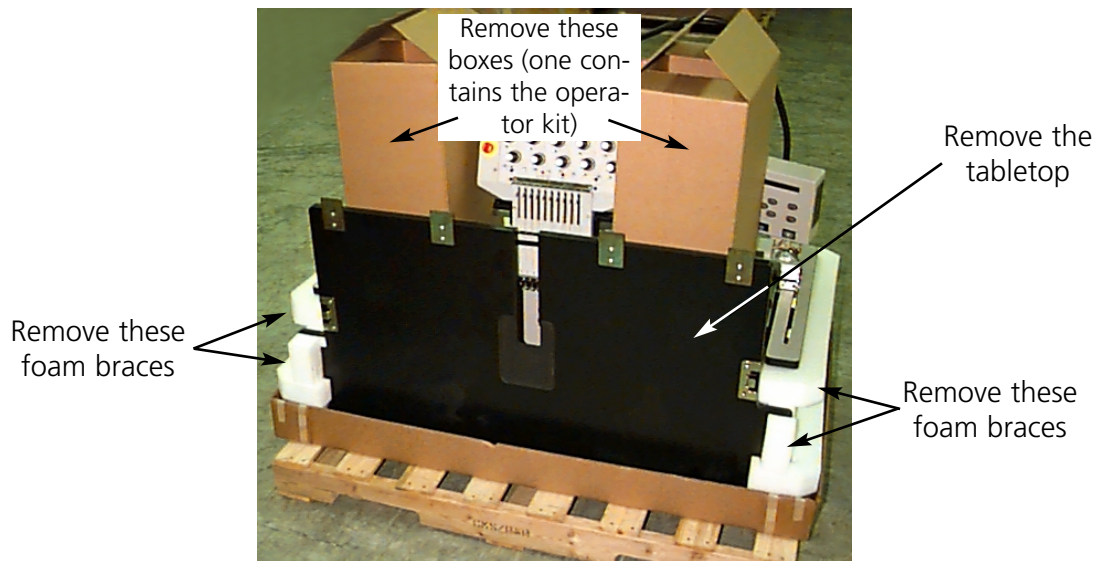
# 1. Installation

Read the entire manual before operating the machine. Save all packing material; if you ever need to move the peripheral, use the original packing material.

## Unpacking

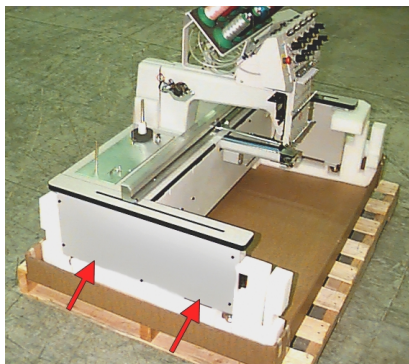
### EMT 10T F1

Remove the packing straps holding the box together using a knife. Lift off the top of the box, and then remove the sides of the carton. Remove the plastic bag enclosing the equipment. When the plastic is off, refer to Figure 1-1 for further instructions.



**Figure 1-1**

Prepare the designated area for the peripheral. If you have purchased the cart option, you must clear a temporary location for the machine (until you have assembled the cart). If you purchased the foot option, install the 4 feet before removing the machine from the box. Two people are required to lift the EMT 10T. Refer to Figure 1-2 to locate the hand-holds, and lift as shown in Figure 1-3.



**Figure 1-2**



**Figure 1-3**

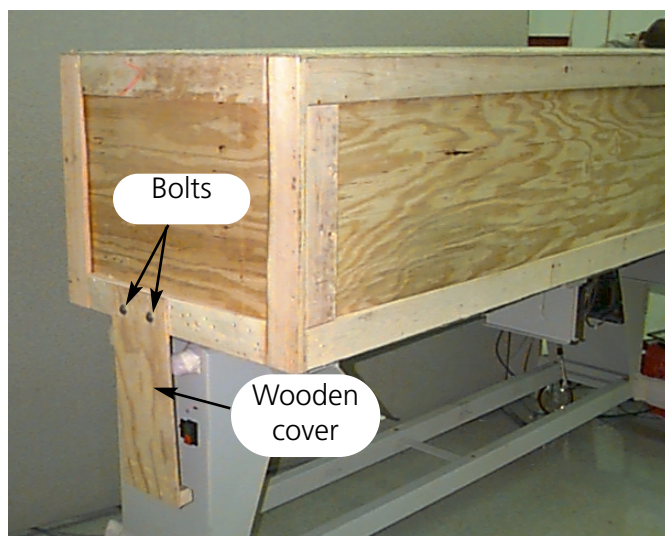
## EMT 10/4 and 10/4T

There are two versions of the EMT 10/4 and 10/4T machines, and each are shipped in a different way. Domestic models are shipped with a “coffin-style” crate surrounding the heads. International models are shipped in a full crate and are packed on a pallet within the crate. Determine which style you have, and refer to the pertinent section.

### Domestic models

Two people are required to unpack the EMT 10/4 or 10/4T. Be careful when unpacking your new peripheral. On one end of the “coffin-style” crate is a wooden cover that protects the power switches during shipment (refer to Figure 1-4). 2 bolts secure this cover to the crate. remove both bolts, and remove the cover. Along the back of the crate are 2 “L” shaped brackets; these brackets hold the crate to the frame, protecting the heads. Remove the bolts holding the bracket to the crate, then remove the bolts holding the bracket to the frame. When the bolts have been removed, remove the bracket.

The crate weighs 115lbs (52.3kg) and is very awkward, so use caution. With one person standing at each end of the crate, **carefully** lift the crate until it is clear of the heads. Remove the crate. Store all packing materials and hardware in a safe place. Reuse the packing materials if you ever relocate the peripheral.



**Figure 1-4**

### International models

Two people and a forklift are required to unpack the EMT 10/4 or 10/4T. Be careful when unpacking your new peripheral. On one end of the crate is a "window" of wood. This end is the door. Open the door by removing the nails from around the perimeter. Next, remove the nails from around the bottom perimeter of the box. Slide the crate off the pallet. Use a forklift to lift the peripheral off the pallet. Place the forks in the locations shown below.

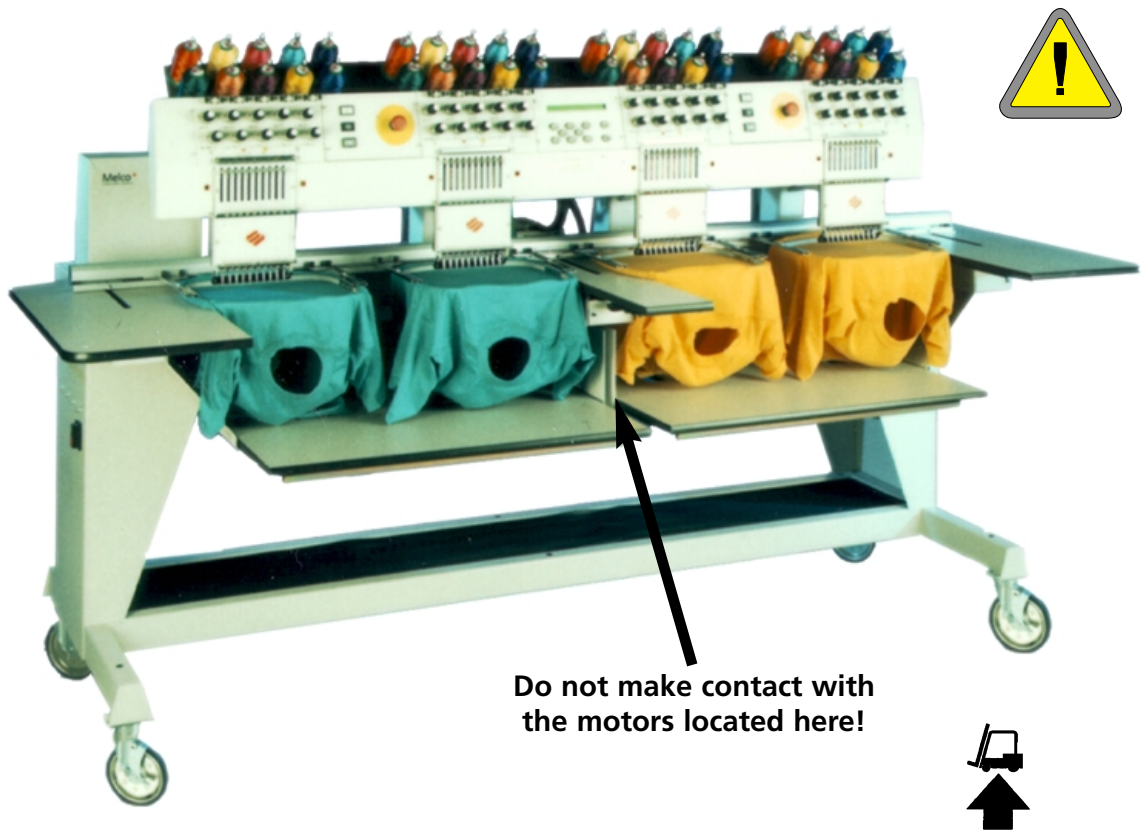


Figure 1-5

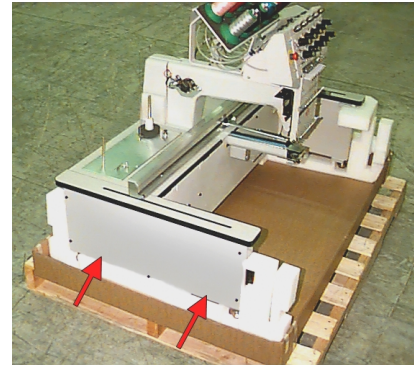
## Moving the Peripheral

Make sure you leave enough room around your peripheral to have easy access to all sides.

### EMT 10T F1

Use two people to lift the machine; use the hand-holds shown in Figure 1-6.

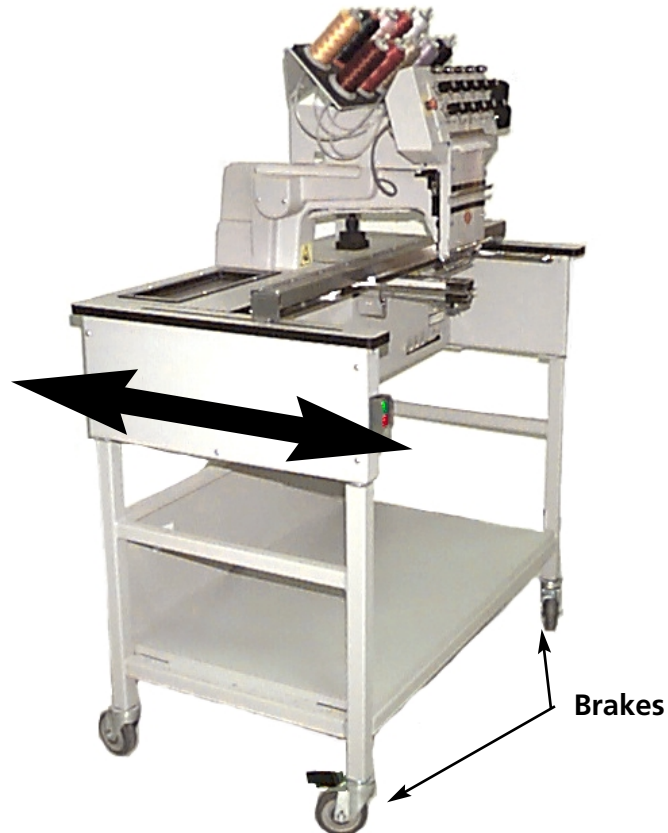
If the machine is on a cart, disengage the brakes on the indicated wheels before attempting to move the machine. Engage the brakes when the machine is in the desired location. Observe the precautions below. You cannot remove the machine from the cart without first removing the 4 bolts securing the machine to the cart.



**Figure 1-6**



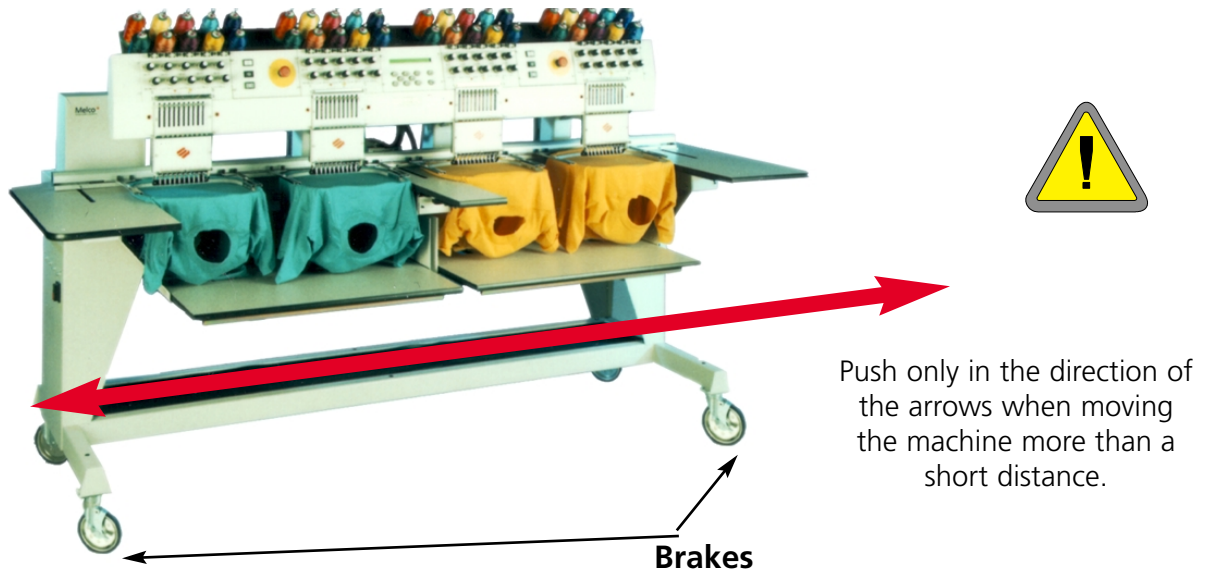
Push carefully in the directions shown or the cart may tip.



**Figure 1-7**

**EMT 10/4 and 10/4T**

Move the machine as indicated below. Disengage the brakes on the indicated wheels before attempting to move the machine. Engage the brakes when the machine is in the desired location.

**Figure 1-8**

### Cart Assembly (EMT 10T F1 Only)

If you purchased the optional cart with the EMT 10TF1, you must assemble the cart and mount the peripheral on the cart. The following section describes how to assemble the cart and attach the EMT 10TF1. To dismantle, reverse these steps.

The cart has 5 pieces. They attach as shown in Figure 1-11. Use the enclosed hardware to build the cart. Pieces **1**, **4**, and **5** are identical to each other. Pieces **2** and **3** are also identical to each other.

Referring to Figure 1-9 and 1-10, lay piece **1** on top of the existing cardboard packaging with the straight flange pointing down. Attach piece **2** with wheels on the same end as the straight flange on piece **1** (see Figure 1-10). The wheels with the brakes on them should be on the ground as shown in Figure 1-9. Insert the necessary screws (M5 phillips head screw with a flat washer between the screw and the cart piece) securing them tightly. Attach piece **3** the same way. While standing in area indicated in Figure 1-9, grasp and carefully lift cart off of cardboard and place all four wheels onto floor.

Referring to Figure 1-11, place pieces **4** and **5** resting on top of the cross bars of pieces **2** and **3** and piece **4** resting on the straight flange of piece **1**. The straight flange of pieces **4** and **5** will be placed together in the middle of the cart assembly. Insert the necessary screws (M5 phillips head screw with a flat washer between the screw and the cart piece) securing them tightly.

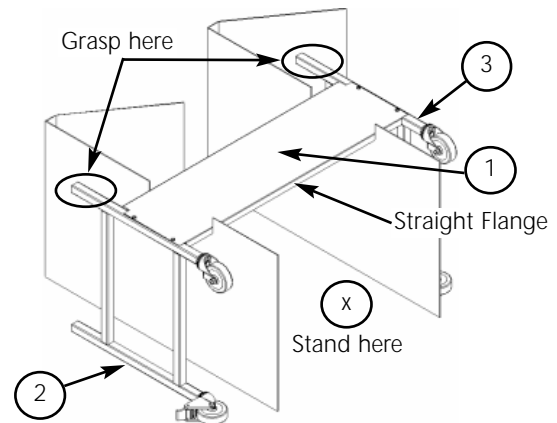


Figure 1-9

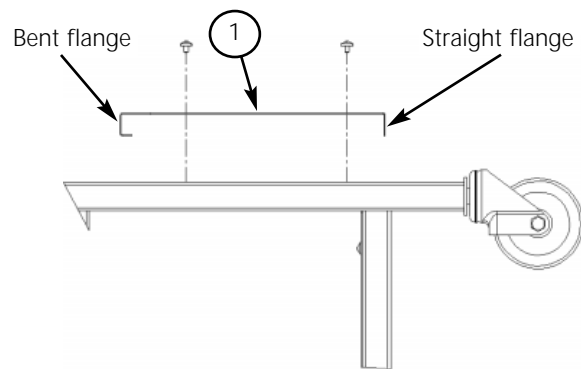


Figure 1-10

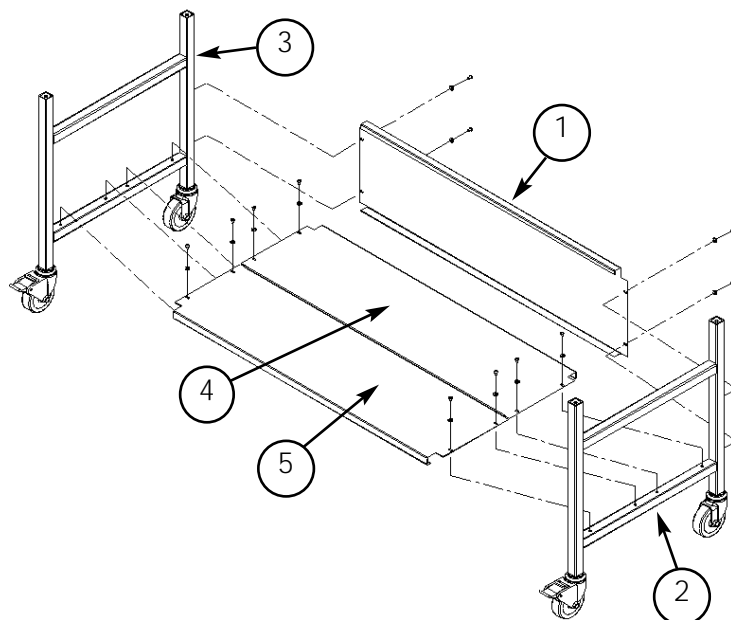


Figure 1-11

### Mounting the EMT 10T F1 on the cart

1. Remove the main tabletop.
2. Remove the side covers; there are 5 screws holding each side cover in place (see Figure 1-12). Use the #2 Phillips head driver included in the operator kit to remove the screws.

**Caution! The side panels are heavy; if dropped, damage may occur.**

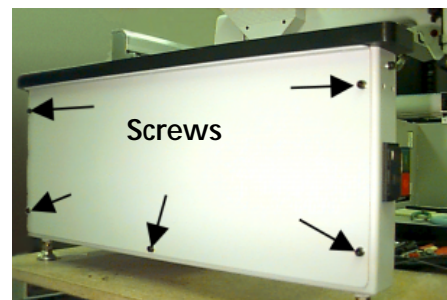


Figure 1-12

3. Lift the EMT 10T F1 (2 people are required) and carefully place the machine on the “pillars” of the cart. The 4 holes where the feet attach should be aligned with the 4 holes on the cart’s pillars. If the holes do not match up then slightly loosen all of the cart screws for flexibility.
4. Secure the machine to the cart using the M6 socket-head cap screws, a flat washer, and a lock washer (provided with the cart). Refer to Figure 1-13. Install the flat washer, then the lock washer, then the bolt.
5. Make sure the cart is standing straight, tighten all screws.
6. Replace the side covers.
7. Replace the tabletop (if desired).



Figure 1-13

### Installing the feet

If you have purchased the Foot option with your EMT 10TF1, refer to these steps to install the feet.

1. Remove the main tabletop.
2. Remove the side covers; there are 5 screws holding each side cover in place (see Figure 1-12). Use the #2 Phillips head driver included in the operator kit to remove the screws.

**Caution! The side panels are heavy; if dropped, damage may occur.**

3. Working on one side at a time, raise the machine and support it securely. The machine should be lifted approximately 4" (10cm).
4. Install the 4 “feet” on the peripheral (see Figure 1-13b). Turn the indicated flat section of the stem with an adjustable wrench to install or remove the foot on to the peripheral.
5. Place the machine on the surface where you intend to use it, and level the machine. Adjust the appropriate feet by turning the stem up or down and secure with the lock nut against the peripheral.

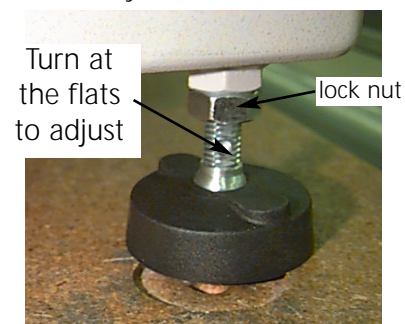


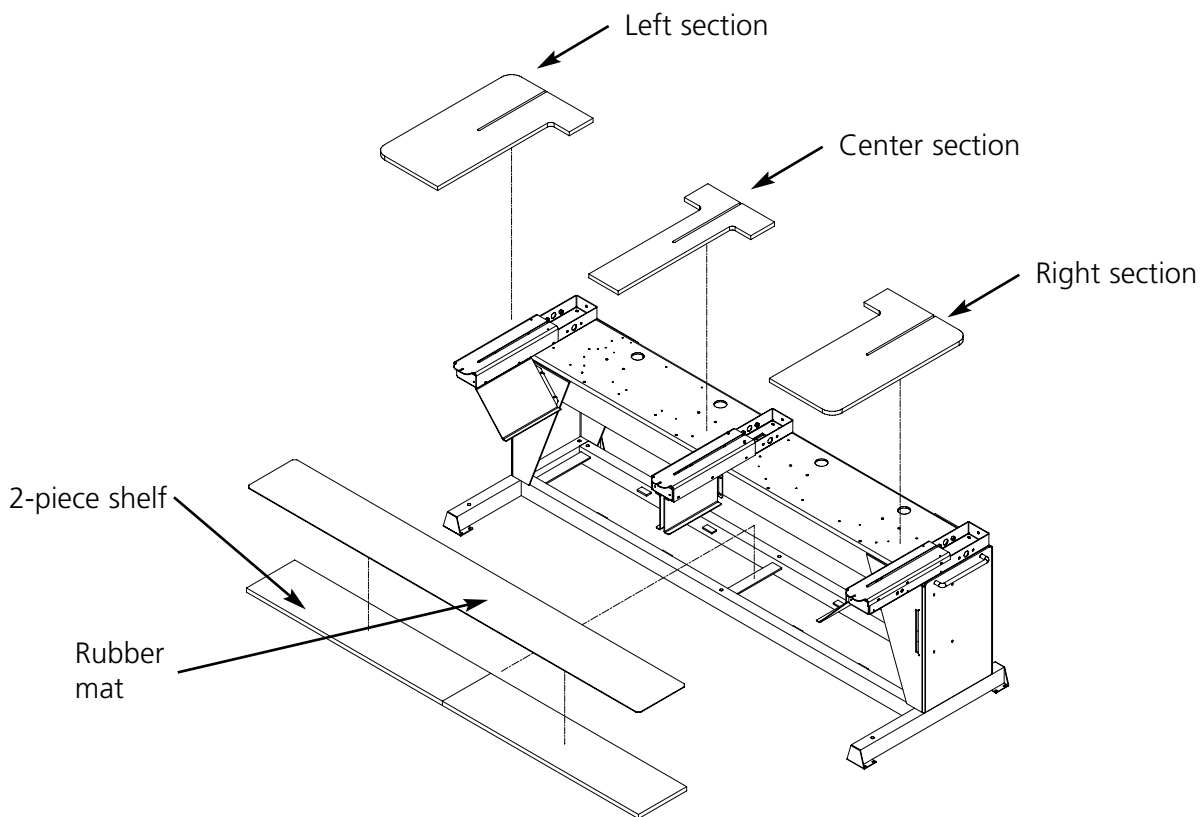
Figure 1-13b

## Installing the tabletop (EMT 10/4 Only)

You only need to install the tabletop on the EMT 10/4 if you are going to embroider flat goods or use the sash frame. To install the tabletop, refer to the instructions below.

The tabletop is shipped in five parts (see Figure 1-14). The two ends and the center section slide into place in the positions shown in Figure 1-14. The remaining two sections slide into place as shown in Figure 1-15. This design makes it easy to remove the tabletop to embroider tubular goods, to embroider with a cap frame, or to perform routine maintenance.

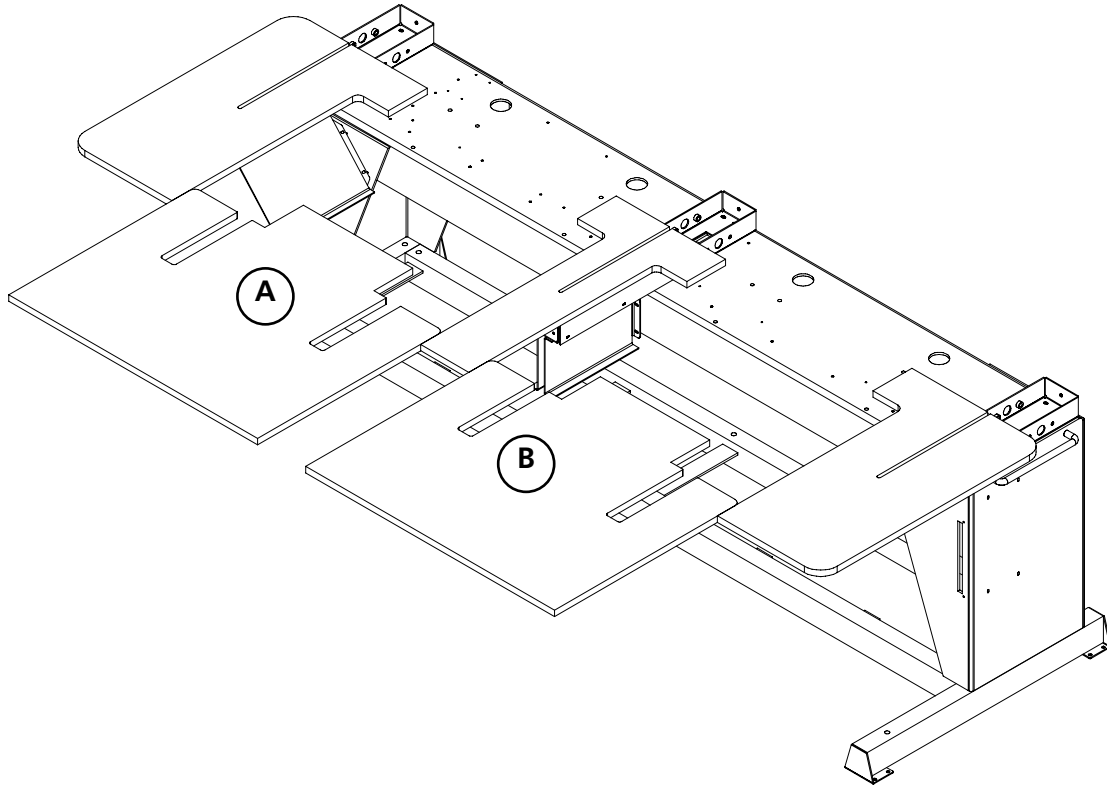
1. Using four thumb screws for each section, slide the right, left, and center sections into the metal channels on the table. The screws are inserted from the underside of each piece.
2. There is a 2-section shelf and a covering mat that comes with the table top assembly (see Figure 1-14). Place the shelf pieces on top of the brackets located in the base of the machine and lay the mat on top of the shelf pieces.



**Figure 1-14**



- Slide the last two pieces into place (see Figure 1-15). They fit on the table support tabs on the end and center sections.
- Tighten the thumb screws under the table to secure the pieces.



**Figure 1-15**

**Special note on the tabletops**



You **MUST remove all 5 tabletop inserts** before embroidering tubular goods or caps on the EMT 10/4 or 10/4T. Failure to do so may result in damage to the equipment or bodily injury. You may use parts **A** and **B** of the tabletop (in Figure 1-15) in the **LOW-ERED POSITION** to support heavy garments during tubular embroidery only.

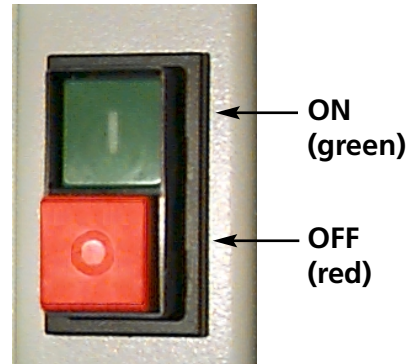
## Connecting cables

### Power requirements

Melco suggests using a dedicated line with a line conditioner (available from Accessory Resource Corporation). Do not use any power cable that appears to be damaged. If your power cable appears to be damaged, order a new power cable from your Melco representative.

#### EMT 10T F1

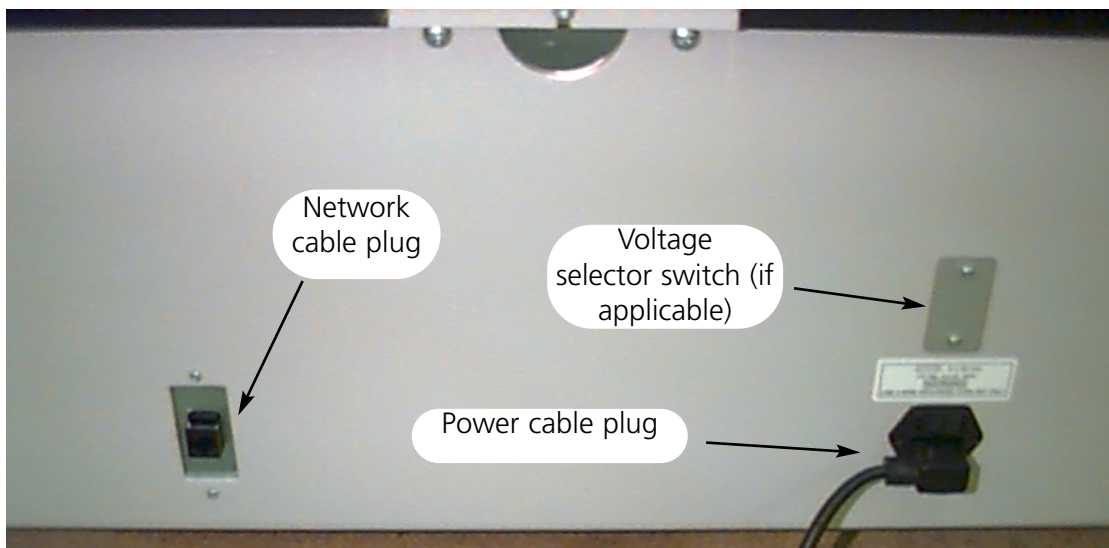
1. Figure 1-16 shows the power in the ON position. Turn the power OFF before connecting ANY cables.
2. If your peripheral is equipped with a voltage selector switch, set it to the correct position for your area.
3. Plug the power cable to the rear of the unit as shown in Figure 1-17.
4. Plug the other end of the cable into the line conditioner.
5. Connect the line conditioner to the power source.



**Figure 1-16**

Note: The fuses have been installed for the voltage in your area; if you use a voltage other than the factory preset, make sure you replace the factory fuses with appropriately rated fuses. Refer to Chapter 4 for more information about fuses.

#### Rear of peripheral

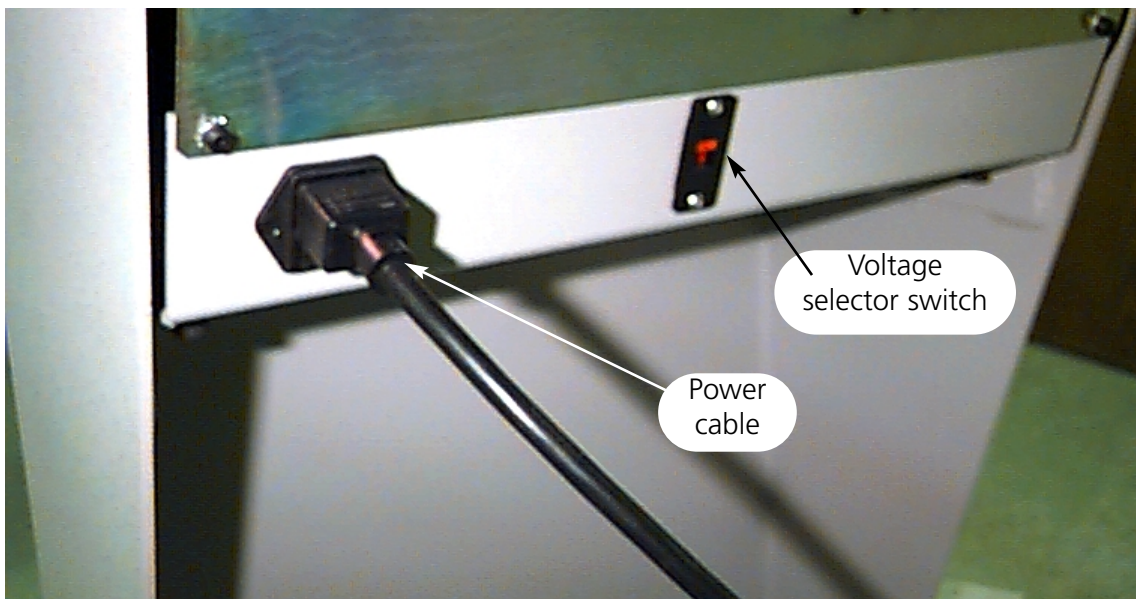


**Figure 1-17**

**EMT 10/4**

1. Figure 1-16 shows the power in the ON position. Turn the power OFF before connecting ANY cables.
2. If your peripheral is equipped with a voltage selector switch, set it to the correct position (115VAC or 220VAC) for your area.
3. Plug the power cable to the leg of the unit as shown in Figure 1-18.
4. Plug the other end of the cable into the line conditioner.
5. Connect the line conditioner to the power source.

Note: The fuses have been installed for the voltage in your area; if you use a voltage other than the factory preset, make sure you replace the factory fuses with appropriately rated fuses. Refer to Chapter 4 for more information about fuses.

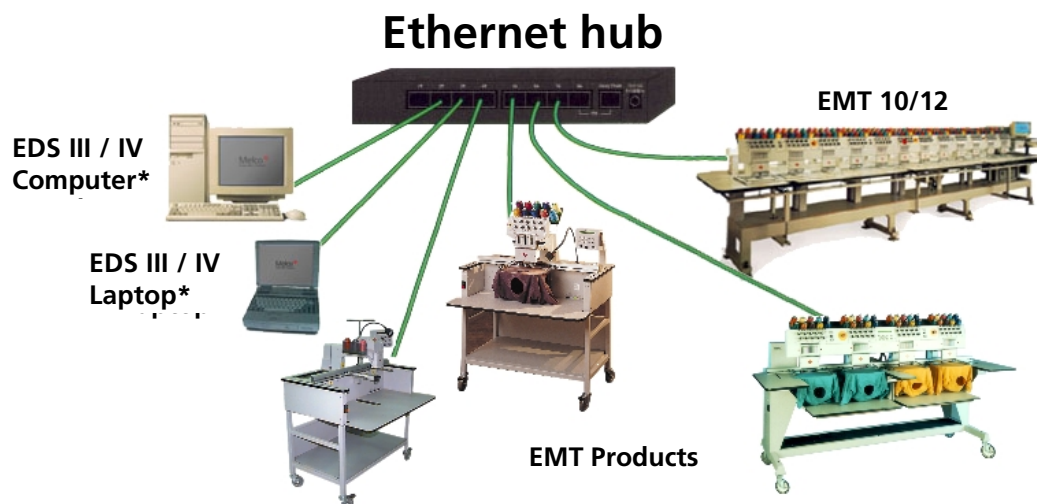


**Figure 1-18**

### Attaching the peripheral to a network

The EMT product line is compatible with Ethernet network technology. With Ethernet, peripherals connect to a wiring hub, and the hub connects to an EDS III or EDS IV computer. The hub is a small electronic device that contains a number of cable jacks and diagnostic lights. The peripherals, EDS III computers, and EDS IV computers can plug into any port on the hub. You can connect as many peripherals or computers as your hub can hold. If you have more peripherals or computers than your hub has ports, you can daisy-chain 2 (or more) hubs together.

Refer to Figure 1-19 for a sample Ethernet network.



**Each cable may be up to 100 meters (327 feet) long. Hubs may be daisy-chained for more capacity or distance.**

**Figure 1-19**

*\*Note: You may have as many licensed EDS III / IV systems operating on an Ethernet network as you choose. Each computer running EDS III / IV on the network must have a licensed EDS System (including the dongle) installed to operate properly.*

## First powerup Installation Note

**Important Note:** Please follow this procedure immediately after unpacking.

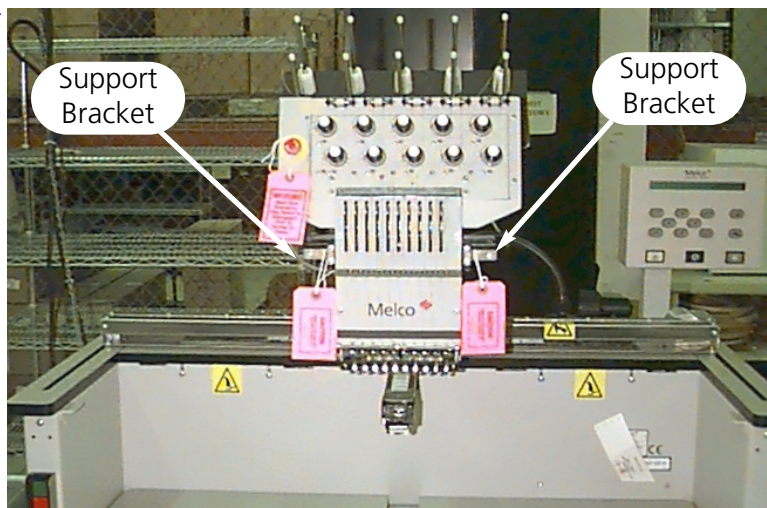
There are two support brackets, one on the right side of the needle case and one on the left side of the needle case to stabilize the needle case during shipping.

1. Your machine must be on a stable surface or mounted to the cart.

2. Locate the power cord in your operator's kit and plug your machine into a stable power source.

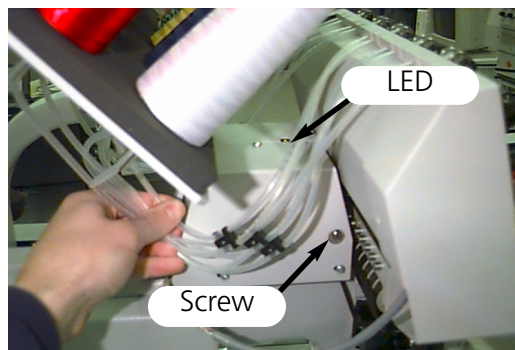
3. Remove the two supports (a caution tag is attached to each). Refer to figure 1-20

4. Turn ON the power and boot machine up (refer to page 2-20 for booting). You will get a NOT AT HEADUP error, this is normal. The following instructions will allow you to proceed with the installation.



**Figure 1-20**

5. Locate the Color Change screw (it is the recessed slotted screw). On the EMT 10T, it is on the left side of the head (as you are facing the machine), behind the needle case. On the EMT 10/4 and 10/4T it is on the right side of the head #1 (as you are facing the machine), behind the needle case. Figure 1-21 shows the location on the EMT 10T F1. The LED and screw are in the same locations behind head #1 on an EMT 10/4 or 10/4T.



**Figure 1-21**

6. There is an LED light behind the main tensioner assembly on top of the sewing head casting. Refer to figure 1-21. When the light is on, the needle case is OFF COLOR INDEX.

Turn the screw, left or right, using a standard screw driver until the light goes off.

7. Using your keypad (refer to page 2-6 for keypad definitions), press your Menu key until you reach the FUNCTION MENU. Press your Enter key. Using your down arrow key, scroll down to GOTO HEAD UP. Then press the Start button, this will take it to HEAD UP. Turn machine off.

- Please refer to the installation section of the Installation, Operation, and Maintenance manual to continue setting up your machine.

### Diagnostic tests

Every time the peripheral powers up, it goes through a series of diagnostic tests. A series of messages will flash on the display. These diagnostic tests verify the proper function of the peripheral's CPU and the network card (if present). After the tests, the BIOS revision level will be displayed; if you are running an Ethernet network and no EDS computer is on-line, the display may read: Insert Boot Disk.












If any of the diagnostics fail, the CPU will halt and the machine will not boot. This indicates a problem with the CPU. Contact your Melco Service Representative.

### Configuring the peripheral

The first time the machine is turned on, it must be configured with a peripheral program and unit name. This information is stored in memory and retrieved during each power up. **If the peripheral is not configured correctly, it will not operate properly and may be damaged.**

The unit name is a unique address for each machine. The machine uses the unique EtherNet address as a default. You may change this to any 16 (or less) character name. Use a unique name for each machine if you have more than one machine on your network.

#### To configure the peripheral:







- Turn ON the power.
- Ignore any message flashing on the LCD.
- Press and hold    at the same time within 12 seconds after you turn on the power.
- Continue to hold the keys until the machine beeps, then release.
- The LCD should display the model name; press  or  to scroll to the correct model name for your machine.
- Press  and the peripheral program is set.
- Press  or  to change the characters in the name and press  or  to move to the next or previous character.
- Press  to set the unit name.

The machine should now be properly configured.

## Language selection

All Melco products use English as the default language. If you wish to change the display to a different language, follow these steps to select the machine language:

Note: The machine must be configured before you can change the display language.

1. Press   to enter Language Selection
2. Press  or  to scroll through the available language selections.
3. When the desired language is selected, press   to return to the Main Menu.

Note: You can only change the language after the machine has downloaded the RSA files.





# 2. Operation

This chapter outlines machine operation; in addition, operators must attend a Melco approved training course prior to operating the machine.



Figure 2-1

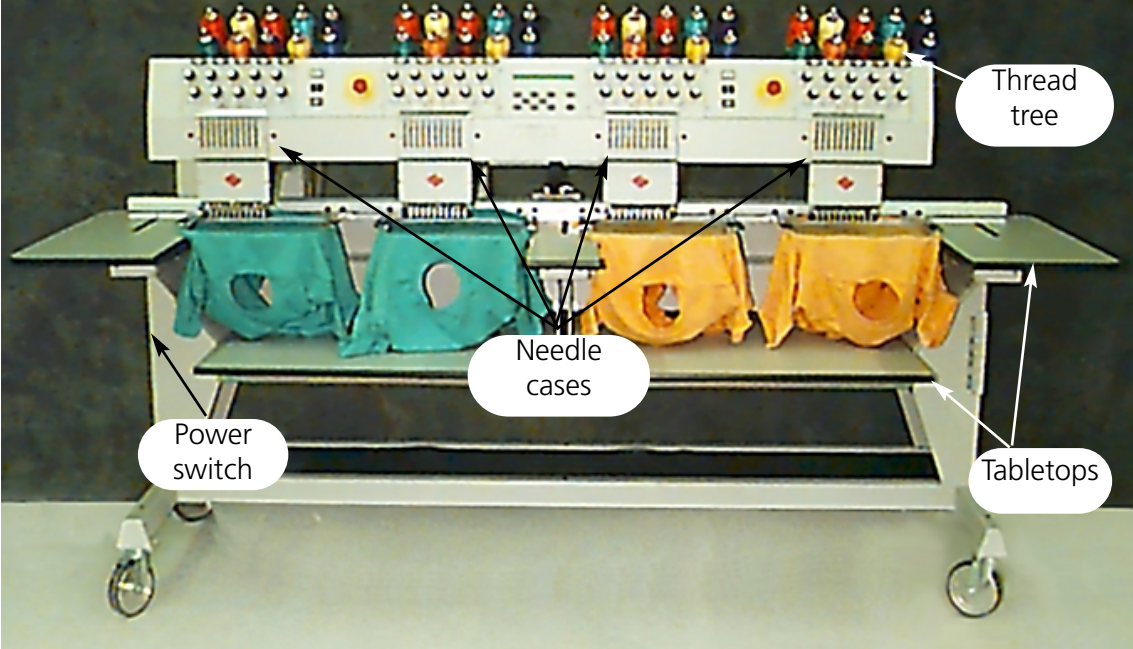
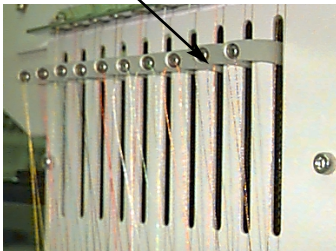


Figure 2-2

### Hazards of operation



**Caution! Below are risk areas or danger points encountered during operation. Always wear eye protection while operating the machine to prevent injury in the event of a needle break. Do not wear loose or baggy clothing when operating the machine.**



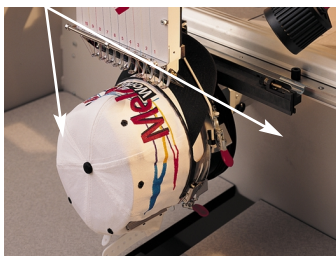
#### Take-up Lever Oscillation

Do not touch the take-up levers during operation



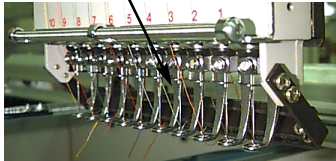
#### Needle Case Movements

Do not place hands or other objects on or around the needle case during operation.



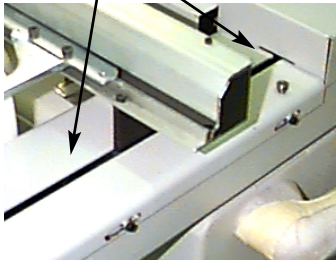
#### Cap Frame Pinch Points

Do not touch the cap frame, driver, or driver bar during operation.



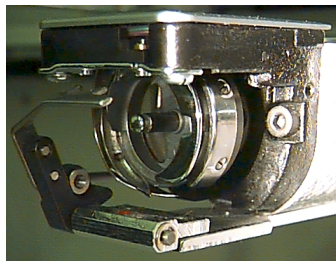
### Exposed Needles During Operation

Do not place body parts or other foreign objects under the needles during operation.



### Pinch Points

Do not rest hands or other objects on the table top during operation. Do not reach behind the x-carriage during operation with or without table top in place.



### Rotary Hook Rotation

Do not attempt to change bobbin thread during operation. Do not place hands or other objects in the rotary hook area during operation. Do not operate the machine without the hook guards in place.

### Threading

Push the metal thread tubes up from behind the head, and remove the magnetic strips from the front of the heads. Place a cone of thread onto the stand and push the first few inches of thread into the supply tube. Use a can of compressed air to blow the thread through the supply tube.

If you do not have compressed air, use the clear monofilament (approximately 24" or 70cm long) provided in the operator's kit. There is a small hole behind the pretensioners; Push the monofilament into this hole and up through the supply tube, then "hook" the thread on the cut and pull the thread through the tube.

The thread tube should extend approximately 0.5" above the thread cone

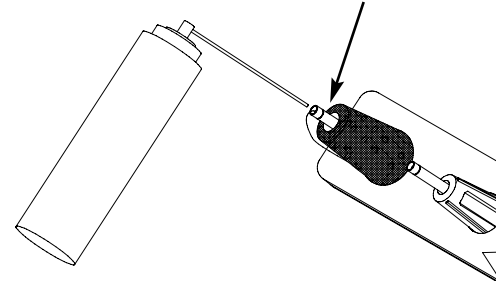
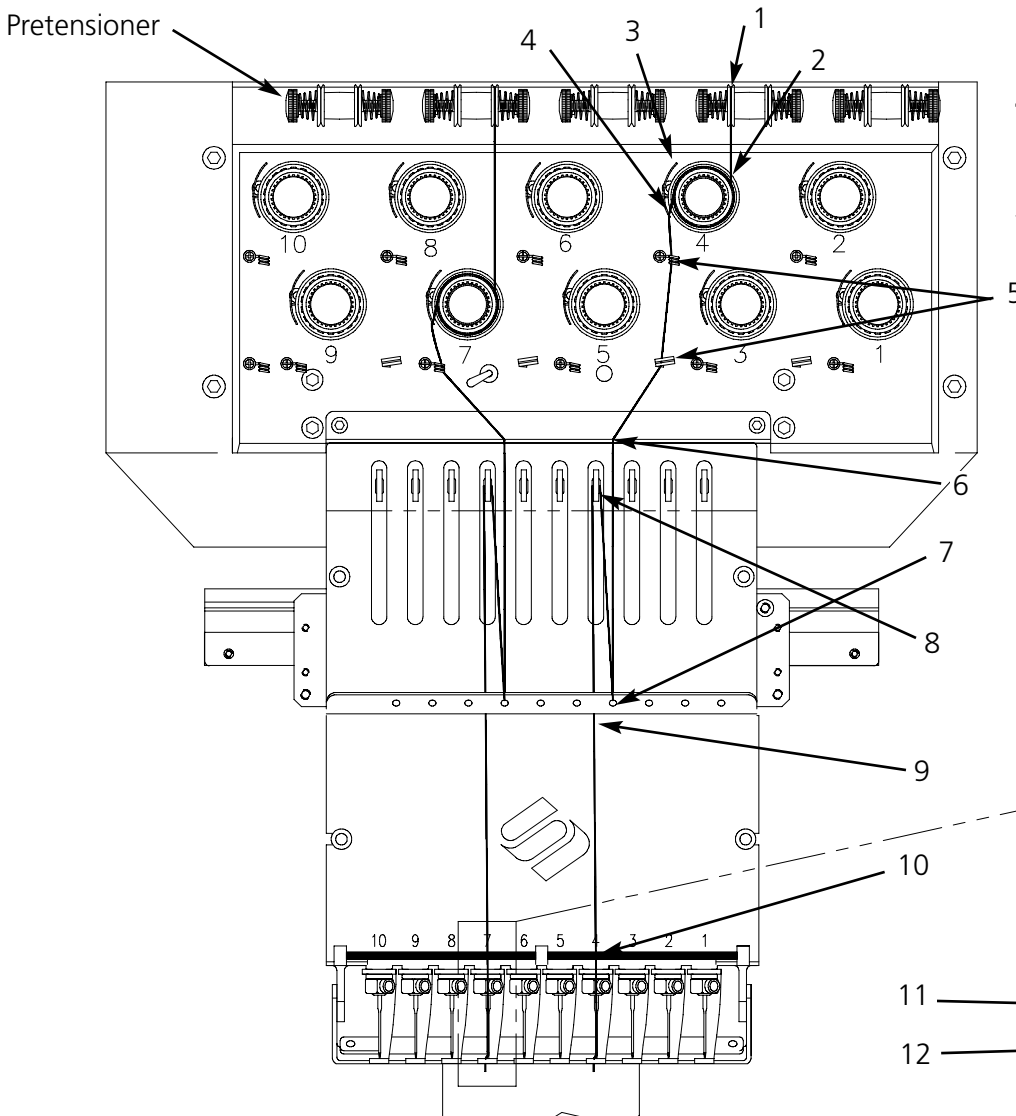


Figure 2-3



**THE THREAD PATH**  
Numbers here represent numbered steps from the following page.

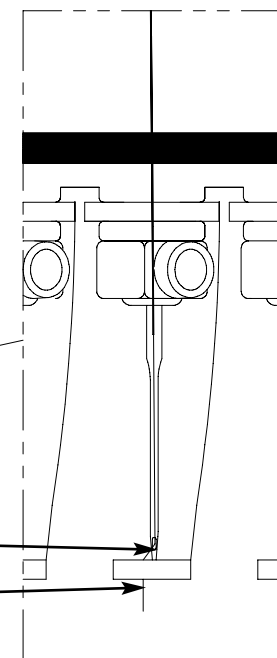


Figure 2-4

1. Pull the thread from the guide hole down between the pretensioner disks.
2. Route the thread down through the pretensioner, between the two metal wheels.
3. Pull the thread down to the main tensioner and wrap the thread around the disk clockwise 1½ times.
4. Route the thread through the tension take-up spring. When you tug on the thread, the take-up spring should move and break contact with the thread break sensor post.
5. Route the thread down through the thread guide post(s). Threads using the top tensioners have two posts, threads using the bottom tensioners have one post.
6. The upper thread guide is just above the the take-up levers. Route the thread through it.
7. The middle thread guide is just below the take-up levers. Route the thread though the hole facing outward, from back to front.
8. Bring the thread through the take-up lever eye, from right to left.
9. Route the thread straight down to the middle thread guide, through the hole facing downward.
10. Drop the thread through the lower guide, just above the presser foot.
11. Run the thread through the eye of the needle, from front to back.
12. Pass the thread through the center of the presser foot.
13. Pull on the thread until you feel tensioner pressure.
14. Set the tension to equal 80-120 grams required to pull the thread at the needle end.
15. Fasten the thread to the retainer spring and trim the end to about an inch in length.

### Tensions

Embroidery tensions are controlled on both the upper and bobbin thread. To set the tension, sew a column (satin stitch), or embroider a capital letter "I". You should have bobbin thread across approximately ⅓ of the total column width on the back. If you do not, refer to the following table to adjust tensions.

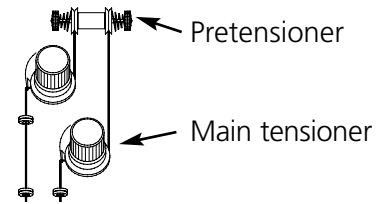
Note: Do not attempt to judge tension by looking at the back of a fill stitch.

<b>Problem</b>	<b>Solution</b>
Bobbin thread showing on top of garment	Top tension too tight and/or bobbin tension too loose
More than 1/3 of column showing bobbin thread on back of garment	Bobbin tension too loose and/or top tension too tight
Less than 1/3 of column showing bobbin thread on back of garment	Bobbin tension too tight and/or top tension too loose
Design puckering	Top and/or bobbin tension too tight
Top thread in design loose (looping)	Top tension too loose

**Top tensions**

**Pretensioners**

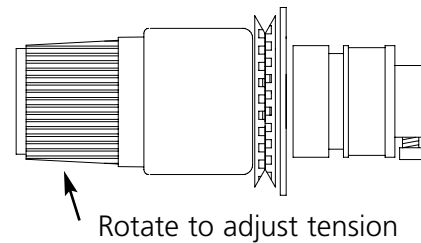
The purpose of the pretensioner is to hold the thread taut for the main tensioner. The thread should pull easily through the pretensioners.



**Figure 2-5**

**Main tensioners**

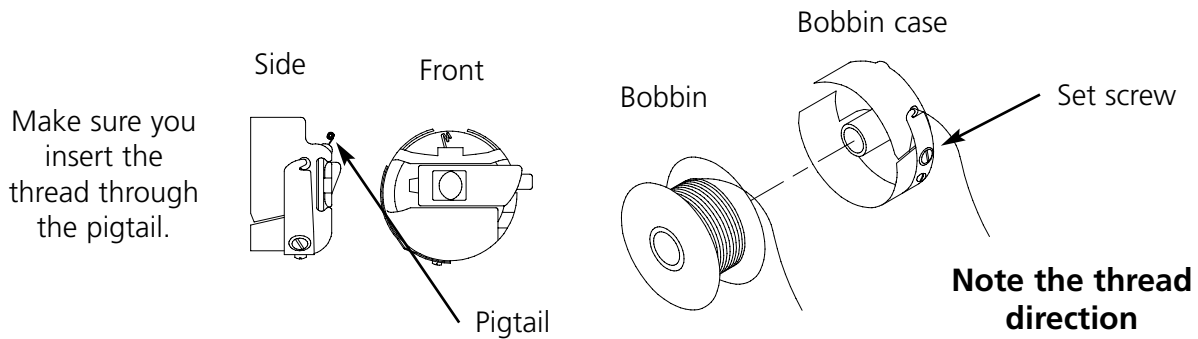
Sets the upper tension. Tighten tension by turning the knob clockwise. Loosen by turning counterclockwise.



**Figure 2-6**

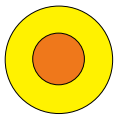
**Bottom tensions**

Leave 2-3 inches (5-7.5cm) of thread hanging free. Insert the bobbin and case with the pigtail facing up. Set the tension at approximately 7-14 ounces (20-40 grams) required to pull thread from the bobbin.



**Figure 2-7**

**Keypad**



Emergency Stop (Bright yellow with a red center); stops all sewing motion immediately. To reset, pull or twist slightly and the button snaps back into place.




Starts embroidering (sometimes referred to as the start button). It is also used to execute selected functions in the Function menu.













Stops machine motion. Press twice to enable manual jogs of the rack when you are in the middle of a design.















Used to "frame forward" or "frame backward" in idle or in the FRAME menu. Holding the key will cause the machine to frame one stitch at a time; release the key to stop framing. Holding the key for 10 seconds starts the auto-frame function; once the auto-frame function has started, you must press  to stop framing.




The framing direction can be changed in the FRAME menu of the Main Operator Menu.

-  Moves from one menu to the next. After the last menu displays, it wraps back to the first menu.
-  Never used alone. It is held down while pressing an additional key, allowing the other key to take on an alternate function.
-  Moves the needle position to the right in the embroidery field (hoop moves left). It is also used to select values for sub-menu options and for manual color changes.
-  Moves the needle position to the left in the embroidery field (hoop moves right). It is also used to select values for sub-menu options and for manual color changes.
-  Moves the needle position back in the embroidery field. It also scrolls up a menu list. It is also used to change sub-menu values.
-  Moves the needle position forward in the embroidery field. It also scrolls down a menu list. It is also used to change sub-menu values.
-  A color change enable switch; hold down and use the left and right arrow keys to manually.
-  A rack enable switch; hold down and use the arrow keys to manually jog the rack.
-  Makes a selection. It is similar to clicking the OK button in Windows or pressing the [ENTER] key on your keyboard.
-  Toggles the hoop carriage speed fast or slow when manually jogging the rack.



### Hotkeys

-   When pressed simultaneously, displays the previous menu.
-   When pressed simultaneously, exits any sub-menu and displays one of the idle menus, even when the machine is embroidering.
-   Toggles between the **Main menu** and the **Service/maintenance menu**.
-   Increases sewing speed by 50 spm (while machine is in operation).
-   Decreases sewing speed by 50 spm (while machine is in operation).
-   Toggles to Language Selection from current menu.

## The Menus

The menu structure is divided into two top-level menus, the **Main Operator menu** and the **Service/Maintenance menu**. To toggle between these top-level menus press  . To enter any submenu under one of the two top-level menus, press . Following is a list of all the menus available in each and what commands are available. If your machine is not equipped with trimmers, you may not see all the menus and commands listed here.




### Main Operator Menu

The Main operator menu is the menu the machine defaults to when powered up. All functions required for embroidering are found in this menu. Eight submenus are in the Main operator menu. Press   to toggle between the **Main** menu and the **Service/Maintenance** menu.

### Disk Directory Menu

Lists designs on the floppy disk in the EMT Disk Drive. Use  or  to scroll through design names. Press  to load the design into machine memory.

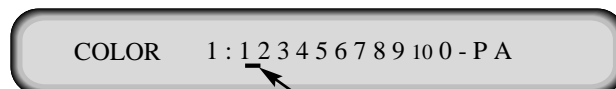
### Design Menu

Lists designs stored in machine memory. Use  or  to scroll through the design names. Press  to select a design to be sewn. Up to 16 designs (or up to 500K) may be queued.

### Color Menu

Used to setup the color/needle sequence. The following characters are allowed:



- 1-10** needle number
- 0** pause at this color change only (does not move to next color)
- skip this color change
- P** pause after all color changes
- A** stop for applique



Needle position



For more information on these characters, turn to page 2-26

### Run Design Menu

Confirms the selected design and color sequence is ready to be embroidered. Press  to load the design into the job queue (up to 16 designs may be queued—or up to 500K). Press  (the machine will emit several beeps) to start embroidering the design.




### Function Menu

All the commands in this menu result in machine motion and multiple beeps. The commands are described below. Press  or  to view selections.



#### Go to hoop center?

Forces an X/Y move to the center of the selected hoop. Only allowed if you are not in the middle of a design. Press  to perform function.


#### Trace design outline?

Traces the outline of the queued design. Press  to perform function. Refer to the **Trace** part of the Quick Start section for more information.

#### Trim immediate?











Forces a trim. Press  to perform function.

#### Set home?

Causes the X and Y axis motors to move to home, then return to their starting positions. This position is defined as home. Press  to perform function. Unless an error condition occurs, this function is performed automatically every time the machine is powered up.


#### Power Fail rescue?

Power Fail rescue allows you to resume embroidering a design after the machine has a power loss. A power loss might occur if an error requires turning the power switch OFF and then back ON for recovery or if a power failure occurs. Follow these steps to regain your position in the design and continue embroidering.

1. If large garments are installed, remove them from all heads while the power is OFF; if you are booting from the disk drive, insert the Boot Disk..
2. Turn the power ON. Wait for the machine to download and power up.
3. Scroll through the menus until the display reads FUNCTION MENU.
4. Press . The display reads GOTO HOOP CENTER?.
5. Press  or  until the display reads GO TO HEADUP.
6. Press ; if you are loading a design from the disk drive, remove the Boot Disk and insert the Design Disk now.
7. Press  or  until the display reads POWER FAIL RESCUE.
8. Press . The beam and carriage assemblies will move to find home, then return to the next to last stitch embroidered before the power failure. This may take a minute or so if it is a large design.
9. Press   to return to the top level menu.
10. Reinstall any large garments that you removed in step 1.
11. Press . **The peripheral will resume embroidering.**











### Return to origin?

Returns to the start position of a design that has been partially embroidered. Press  to perform function.











### Return to last stitching position?

Returns to the last stitched position before continuing if manual jog X/Y was used to view the design. You may use this function if you have manually moved the x or y axis in the middle of a design. this function will return you to the last position a stitch was sewn.

1. When the machine is stopped (but still in the middle of a design), press  along with any arrow key to move the hoop.
2. Scroll to the Function Menu and press .
3. Press  or  until the display reads **Return to last stitching position?**
4. Press ; the machine will return to the last stitched position in the design.
5. Press   to return to the top-level menu.
6. Press  to resume embroidering.









### Go to stitch?





Allows you to move to a specified stitch number within a design. For example, you may use this function to move to a certain position in a design that may not have sewn well.

1. From the Function Menu, press  or  until the display reads: **Go to Stitch?**, then press .
2. Use the arrow keys to enter the desired stitch number (see illustration).  

3. Press ; the machine moves to that stitch.  
 Press  or  to change the cursor position
4. If you were in the middle of a design when you performed this function, press   to return to the top-level menu, and press  to resume embroidering.


### Go to color change?

Allows you to move to a specified color change number within a design. For example, you may use this function to move to a certain color in a design that may not have sewn well.





1. From the Function Menu, press  or  until the display reads: **Go to Color Change?**, then press .
2. Use the arrow keys to enter the desired color change number (see illustration).  

- Press  or  to change a character
- Press  or  to change the cursor position

3. Press  ; the machine moves to that color change.
4. If you were in the middle of a design when you performed this function, press   to return to the top-level menu, and press  to resume embroidering.

### Go to headup?

Forces a move to the headup position, ready to sew. Press  to perform function.

### Options Menu

Used to set all machine options. Press  or  to view the selections. Use  or  to select submenu options. All options are stored in machine memory until changed manually or until a hard reset is performed.

### Select hoop:

Lists all defined hoops. The hoops will appear in the units you select during configuration (i.e., English or Metric). The list of defined hoops follows:

- 11.8" X 17.3" (30 X 44cm) Tube
- 11.8" X 14.2" (30 X 36cm) Tube
- 8.3" (21cm) Tube
- 7.1" (18cm) Tube
- 5.9" (15cm) Tube
- 4.7" (12cm) Tube
- 3.5" (9cm) Tube
- 8.3" (21cm) Round
- 7.1" (18cm) Spider
- 5.9" (15cm) Spider
- 4.7" (12cm) Spider
- 3.5" (9cm) Spider
- Sock hoop
- 2.8" X 5.6" (7 X 14.2cm) Large cap frame
- 2.5" X 5.6" (6.3 X 14.2cm) Small cap frame
- 2.8" X 14.3" (7 X 36.2cm) Wide-angle cap frame
- 2.8" X 5.9" (7 x 15.2cm) CCFWAD Cap Frame
- Sash Frame

**Orientation option:**

Select from eight different design orientations represented by the letter **F** (illustrated at right). Used to turn a design within a hoop (e.g., for caps, you would change the orientation).

**Trim jump count:**

Forces a trim function when consecutive jump stitches or needle ups equal or exceed the number entered here. The range is 0-20, with 0 disabling the option. The default value is 8. If you enter a trim value of 1 or 2, the peripheral will trim between letters of an alphabet.

**Turbo mode:**

When disabled, the machine uses a reduced speed-to-stitch table (minus 200 spm on the EMT 10T F1 and minus 100 spm on the EMT 10/4T, which is recommended for heavier goods). This results in higher embroidery quality, but slower embroidery speed. Enabled is the default. The maximum embroidery speed is fastest when Turbo mode is enabled.

**Center design:**

Allows the design to be centered with respect to the start point. Enabled is the default.


**Disk design format:**

Selects the format of a floppy disk when loading designs from a disk. Options are DOS, TAJIMA, BARUDAN FMC, BARUDAN FDR, ZSK, and NO FORMAT. You must choose the format in order to load a design. The NO FORMAT option will remove the Directory menu from the menu tree. This saves keystrokes if you never load designs from the disk drive. Select a format **other** than NO FORMAT to make the Directory menu re-appear.

**Frame Menu**


Selects the frame forward or frame backward function. Change by pressing  or .

**Reset Menu****Clear design**

Clears the current design from the queue (does not delete the design from memory). Press  to perform function.

Note: If you started to perform a Move Command, but decided not to move, you must perform a Clear Design command to continue.

**Hard reset**

Resets all operator selectable options to the default values, clears the current design from the queue. Press  to perform function.

**Service/Maintenance Menu**

Contains all service and maintenance functions. Eleven submenus are in the Service/maintenance menu. Press   to toggle between the **Service/Maintenance** menu and the **Main** menu.

### Head Timing Menu

Use the keystroke guide below to move to each position. Refer to the Hook timing section of Chapter 4 for more information. The Z position (in degrees) will be displayed after each function.



#### Go to headup

Forces the z axis to make one plus rotation and stop with needle in up position.

#### One revolution

Forces z axis to move to headup position with needle in down position.

#### Needle depth

Must be done after One revolution command to insure the z axis is at its proper position.

#### Hook timing

Must be done after Needle depth command to insure the z axis is in its proper position.

#### Top dead center

Must be done after Needle depth command to insure the z axis is in its proper position. Used to set upper dead stop position.

#### 1 degree forward

Forces z axis to move forward one degree.

#### 10 degrees forward

Forces z axis to move forward ten degrees.


#### 1 degree back

Forces z axis to move back one degrees.

#### 10 degrees back

Forces z axis to move backwards ten degrees.

#### Z position

Releases the z axis to allow manual rotation with current z position display in degrees. Press  twice to exit Z position and lock Z axis.

#### **4 Hr Lubrication Menu**

Go to this menu when the message ***time to oil hook*** appears. This menu forces the machine to move the hook to its proper position for oiling. Refer to the Lubrication section of Chapter 4 for the proper place to apply lubricant.

#### **8 Hr Lubrication Menu**

Go to this menu when the message ***8hr maintenance due*** appears. This menu forces the machine to move to the proper positions for oiling. Refer to the Lubrication section of Chapter 4 for the proper place to apply lubricant.

#### **40 Hr Lubrication Menu**

Go to this menu when the message ***40hr maintenance due*** appears. This menu forces the machine to move to the proper position for oiling. Refer to the Lubrication section of Chapter 4 for the proper place to apply lubricant.

#### **80 Hr Lubrication Menu**

Go to this menu when the message ***80hr maintenance due*** appears. This menu forces the machine to move to the proper positions for oiling. Refer to the Lubrication section of Chapter 4 for the proper place to apply lubricant.

#### **480 Hr Lubrication Menu**

Go to this menu when the message ***480hr maintenance due*** appears. This menu forces the machine to move to the proper positions for oiling. Refer to the Lubrication section of Chapter 4 for the proper place to apply lubricant.



#### **2100 Hr Lubrication Menu**

Go to this menu when the message ***2100hr maintenance due*** appears. This menu forces the machine to move to the proper positions for oiling. Refer to the Lubrication section of Chapter 4 for the proper place to apply lubricant.



## Configuration Menu

This menu allows you to configure certain options. Normally these options are only configured once, but you may set them as often as you wish. If a hard reset is performed, all these values will return to their default values. If your peripheral is not equipped with trimmers, some of these menus may not appear. The options follow:



### Thread trimmer:

Disables or enables the trimmers. Enabled is the default. Press  or  to change.



### Trimmer tail length:

Allows a short or long tail length after a trim. Short is the default. Press  or  to change.

### Trim on stitch length:

The stitch length defined here forces a trim when the next stitch is equal to or greater than the selected length. The allowable range is 0-127. 0 disables the option. 127 is the default. Press  or  to change.

### Bobbin detect:

Turns ON or OFF the Under Thread Control (UTC). ON is the default. On the EMT 10T F1, press   to change.



On the EMT 10/4 or 10/4T, refer to the illustration to the right to turn it on or off on individual heads. A **0** means the bobbin detect is turned on for that head, a **-** means it is turned off.

Press  or  to change a character





Press   or   to change the cursor position



### Bobbin detect count:

Allows for selection of consecutive bobbin breaks before machine stops. The allowable range is 0-50. 0 disables the option. 8 is the default. Press  or  to change.



### Lock stitch:

Forces a lock stitch to be inserted at the beginning of every design and on every restart after a trim. Enabled is the default. Press  or  to change.



### Accumulate needle ups:

Accumulates consecutive needle ups and converts them into one motion. Enabled is the default. Press  or  to change.

### Return to design origin at EOD (end of design):

Forces an XY motion back to the position at the start of the design if the end point is not the same. Enabled is the default. Press  or  to change.



**Start rack motion offset:**

Allows a delayed start time of the X/Y rack motion in 5 degree increments depending on different types of material used. Range is 0-20. 0 is normal movement, and the default. This delayed start time may produce better embroidery results on delicate fabrics by allowing the needle to come out of the fabric completely before rack motion occurs. Does not affect sewing speed, instead the rack moves more quickly. Press  or  to change.



**Unit of measure:**

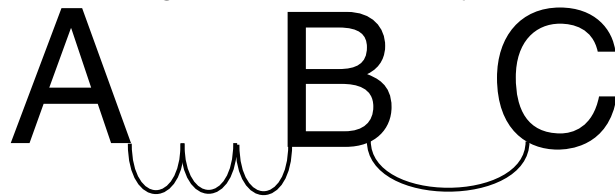
Allows selection of all operator prompts to be in **IN** (English) or **CM** (Metric). English is the default. Press  or  to change.



**Hoop limits:**

Turns ON or OFF hoop limits. Default is ON. If you turn the hoop limits OFF, the machine will **NOT** beep when it encounters a rack limit during a trace. You are at risk to hit the hoop when Hoop Limits are turned OFF. Press  or  to change.

**Design filter:**

Filters a design when it is downloaded to the machine. Filtering removes all stitches equal to or less than the selected short stitch length. Jump stitches and needle ups are changed to normal stitches if their sum is less than 12.7mm. If their sum is longer than 12.7mm, they will be divided into equal jump stitches less than 12.7mm. Refer to the example illustration to the right. 3 jump stitches (20 points each) are converted into 1 normal movement. Enabled is the default. Press  or  to change.

**Design filter stitch length:**

Determines what short stitch length to use for filtering up to 0.9mm. The allowable range is 0-9 points. It accumulates stitches that are shorter than this value and adds them to the next stitch. The default is 4 points. Press  or  to change.



**Language selection:**

Allows for different languages. Several languages are available.

**Inching count:**





Selects number of inching stitches (the slow stitches at the beginning of a design and on restart after a trim or color change) sewn before the machine begins to speed up. These stitches allow the top thread to catch and hold the bobbin thread. The allowable range is 0-9. Default is 3.

**Max Jump Stitch Speed**

Selects the maximum speed that jump stitches can be sewn. The range is 400-900 spm; default is 700 spm.

**Move Function Menu****Move function**

X+00.00 in Y+00.00 in

Forces an X/Y move to a selected distance from the present position. Press   or  to toggle between the X and Y axis. Press  to perform the move.

This is useful to select a position in a hoop that is not the hoop center.

The X and Y coordinates you enter are relative to your current position, NOT to the center of the hoop.





Press  or  to change a character







Press  or  to change the cursor position


## Define custom hoop

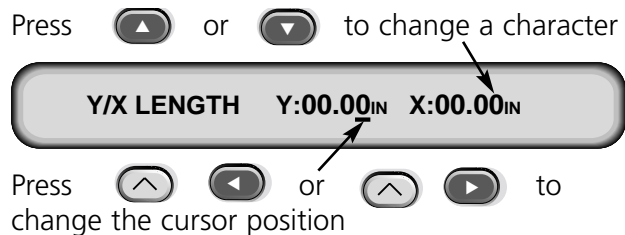
Note: **Before you attempt to define a new custom hoop, center the 11.8" X 17.3" (30 X 44cm) Tube hoop.**




Defines custom hoop sizes based on type of hoop, X/Y dimensions, and hoop center. Press  to start the process. You will be prompted to enter a hoop name (available names are Custom Hoop 1-8). Use  or  to change the hoop name. Press  to go on.

You will be prompted to choose the type of hoop (available choices are rectangle, cap, oval, and circle). Press  or  to select the hoop type. Press  to continue.


You will be prompted to choose the X and Y dimensions (or diameter); refer to the illustration to the right. Press  to go on.

Next you must define your custom hoop's center. To do this, measure from the center of the needle plate to the center of the hoop in the **Y** direction. Enter this value to define the new hoop's center. Press  to go on.



You will be prompted to save the hoop; press  for Yes or  for No. Then press  to save the hoop. Your custom hoop will appear in the hoop list in the Options Menu. You can overwrite a custom hoop, but once you have saved a custom hoop, it will remain in memory until you reconfigure the peripheral.

## Test Mode

Places the machine in test mode, where thread breaks are ignored and the queued design continues to run until  is pressed. Must be disabled to return to normal embroidery. This is primarily a service function.

## Diagnostics Menu

The following service diagnostic test are available to run or view:

### RSA rev level

Displays the current revision level of the RSA files and the selected machine type.

### BIOS rev level

Displays the current revision level of the ROM BIOS.

### Motion Controller rev level

Displays the current revision level of the DSP chip set.

### FPGA rev level

Displays the FPGA (Field Programmable Gate Array) rev level.



### +5 Volt Current

Displays the current supplied by the +5V power supply.



### Sew timers

Displays the total accumulated CPU time, and total sew time. The CPU time accumulates when the machine is turned on, and the sew time accumulates when the machine is embroidering.

### Bobbin Control Test

Allows manual testing of the UTC assembly. A beep will sound every time the bobbin sensor is tripped. Press  to start the test; press  to stop the test.

### Grabber Test

Allows manual testing of the grabber assembly. Press  to extend the grabber, and  to retract the grabber.

## Disk Drive

The EMT Disk Drive is a read only disk system allowing the user to embroider EXPANDED designs in the following formats: DOS 1.44MB, DOS 720K, Tajima, Barudan FMC, Barudan FDR, and ZSK. The drive does NOT support condensed format designs. The disk drive replaces the need for the EDS System Controller, thus converting a peripheral into a single embroidery device.

### Installing .RSA Files

If the peripheral is part of an EDS System and the network will boot the peripheral, you must install the .RSA files into the EDS III / IV computer. To install the .RSA files, start Microsoft® Windows®, put the RSA disk into the disk drive, and follow these steps:

1. Click on **Start→Run** from the Windows 95/98 taskbar (or **File→Run** from the Windows 3.x Program Manager) to display the Run dialog box.
2. Type **a:\setup.exe** and click **Open** (or **OK** if you are using Windows 3.x).
3. Follow the on-screen instructions to install the RSA files.

The operating program or .RSA file for each of the embroidery peripherals that supports the disk drive will automatically load into the computer.

Note: If you upgrade your RSA files, all parameters are automatically set to their default values.

### Configuring The EMT Disk Drive Controlled Unit


If you are operating from an EDS network as well as using the disk drive, install the correct .RSA files as previously indicated and follow the rules of the network when assigning Unit names to peripheral devices. Specifically, after setting the Peripheral Program, the Unit name must be set differently for each peripheral attached to a single EDS System Controller.

If no network is attached to the EMT Disk Drive controlled embroidery peripheral, the Unit name may be set to any name with 1-16 characters.

## Operation

### Booting The Peripheral

You may boot one of two ways. If the embroidery peripheral is properly configured and attached to an EDS System containing the .RSA files, the peripheral will boot from the network when the peripheral is powered up.

If the peripheral is not connected to an EDS System, or if the system is not turned on and operating in EDS, the peripheral will boot from the disk drive. A boot disk must be in the disk drive. If a boot disk is not located in the disk drive, the message: INSERT BOOT DISK will show on the display. Insert the boot disk and press . After the machine boots correctly, it will display the model name.

## Loading a Design



### Through the Network

After the embroidery peripheral is booted, you may load designs into the embroidery peripheral buffer. If you are loading designs through the network, please refer to the EDS III Basic/ EDS IV User manual for a detailed explanation of sending designs from the computer to the peripheral.





### Through the Disk Drive


Once the embroidery peripheral is booted, you may load designs.

#### Directory Menu

1. Press  to display the Directory Menu. If the design format setting in the Options Menu is correct, proceed to the next step. If the format is not correct, see the "Selecting the Format" section below before you proceed.
2. Place the diskette with the design to be loaded in the disk drive, then press  .

The name of the first design in the directory will show on the peripheral display.



3. To load the design showing on the display, press  . If the design name showing on the display is not the design you wish to load, press  or  until the desired design name is showing on the display, then press  .




When  is pressed, the disk drive light comes on as the design is loaded into the embroidery peripheral design buffer. While the design is being loaded, the display shows the name of the design and that it is loading. When loading is complete, the display will show DESIGN MENU.

#### Selecting The Format

Options are DOS, TAJIMA, BARUDAN FMC, BARUDAN FDR, ZSK, and NO FORMAT. You must choose the format in order to load a design. The NO FORMAT option will remove the Directory menu from the menu tree. This saves keystrokes if you never load designs from the disk drive. Select a format **other** than NO FORMAT to make the Directory menu re-appear.

#### Format Selection

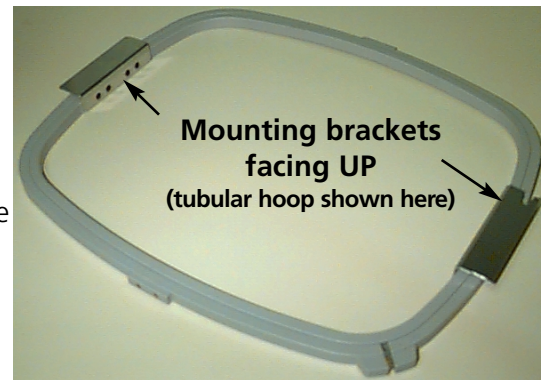
If you need to change the format selection, go into the Options Menu, then press  or  to display **Floppy disk format**. Follow these steps to select a new format:

1. The currently selected format will show on the display. To change the selected format, press  or  until the correct format is displayed.
2. When the desired format is displayed, press  .

## Hooping

Proper hooping is essential for quality embroidery. The garment or fabric must be taut and flat, and the weave or knit must be aligned. Follow these basic hooping guidelines to ensure proper hooping:

- Always hoop on a flat surface
- Use the correct backing
- Use the smallest hoop possible that will accommodate the design within the rack limits (see the Trace menu for more information).
- Smooth the garment as much as possible before hooping, including any lining or backing
- Always check the back of the garment after hooping to make sure there are no wrinkles or parts which will be inadvertently sewn.
- Do not over-tighten or over-stretch the material in the hoop
- Be sure the inner hoop does not extend past the outer hoop on the bottom; both rings of the hoop should be evenly aligned
- Practice



**Figure 2-8**

To hoop with a tubular or flat hoop, place the outer hoop on a clean, flat surface. Place the backing down, then the fabric, and then place the inner hoop inside the outer hoop with the mounting brackets facing UP (see Figure 2-8).

## Quick Start

The following section outlines the required steps to embroider a design.

### Set home






This is normally done on power-up; if the machine detects an error during its test sequence on power-up, you must correct the error condition (e.g., if the machine is not at HEADUP, you must GO TO HEADUP), then Set Home.

Press  until the display reads FUNCTION MENU, then press . Press  or  until the display reads SET HOME. Press . 





### Select hoop

In the Options Menu, press  or  until the display reads SELECT HOOP. Press  or  to scroll to the proper hoop option. Press  to continue.

### Select orientation

In the Options Menu, Press  or  until the display reads Orientation Option. Press  or  to scroll through the orientation options. When the desired orientation is displayed, press  to continue.

### Center hoop

In the Function Menu, press  or  until the display reads GO TO HOOP CENTER?. Press  to center the hoop. 

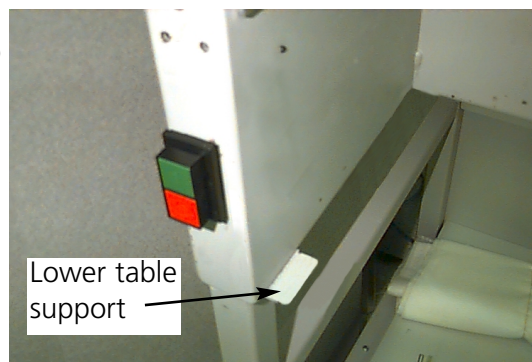
## Attach hoop

Tubular hoops attach to the peripheral via the inner frame (see Figure 2-11). This allows the material to hang down around the frame without being sewn together during embroidery. Flat hoops attach to the peripheral via the outer frame.

### Tubular hoops

Refer to the following steps to attach the tubular hoop to the peripheral:

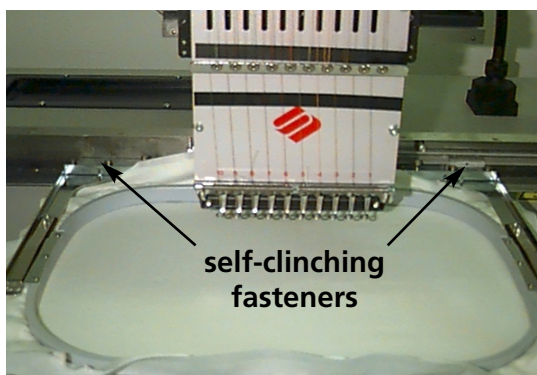
1. Lower the sewing table by lifting the front of the table and pulling it towards you. Place the table top on the lower table supports (Figure 2-9) and push the table top towards the rear of the machine. The table top will snap into place.
2. Attach the tubular frame support arms to the proper self-clinching fasteners on the x-carriage located under the cover (Figure 2-10). The fasteners are accessible through holes in the cover. If the carriage is not in the home position, it may need to be moved to gain access to the fasteners. Make sure the clips (on the ends where the tubular frame will attach) face UP.
3. Insert the hoop frames by sliding the side brackets underneath the spring clips on the support arms. Make sure the slotted bracket (see Figure 2-11) is to the right (as you are facing the machine). Slide the hoop towards the rear of the machine until it snaps into place.



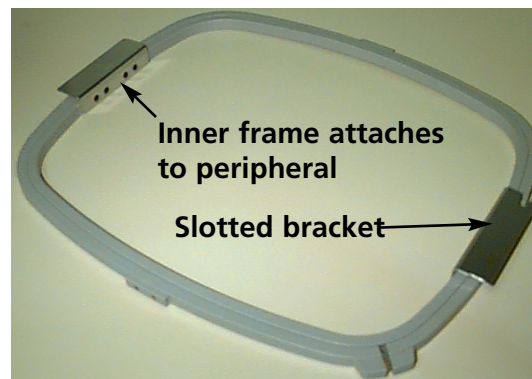
**Figure 2-9**

### Special note for the EMT 10/4 and 10/4T

You **MUST** remove all 5 tabletop inserts before embroidering tubular goods on the EMT 10/4 or 10/4T. Failure to do so may result in damage to the equipment or bodily injury. Refer to Chapter 1 for more information.



**Figure 2-10**



**Figure 2-11**

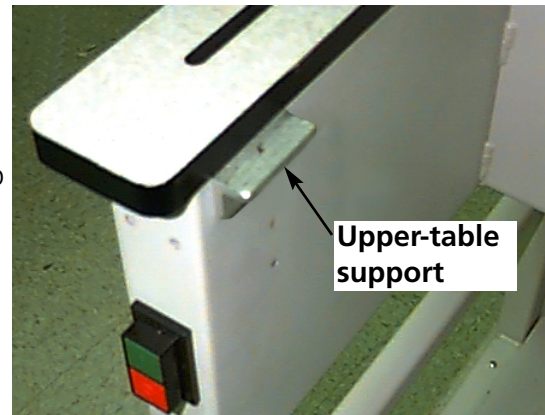


### Flat hoops

You can purchase an optional kit to embroider using flat hoops. Flat hoops attach to the peripheral via the outer frame and attach to the peripheral differently than tubular hoops.

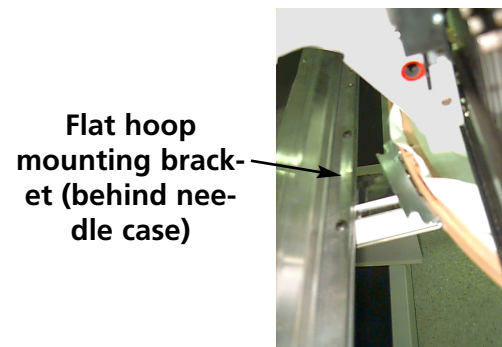
Refer to the following steps to attach the flat hoop to the peripheral:

1. Raise the sewing table by lifting the front of the table and pulling it towards you. Place the table top on the upper table supports (Figure 2-12) and push the table top towards the rear of the machine. The table top will snap into place.



**Figure 2-12**

2. Remove the tubular frame support arms from the front of the X-carriage.



**Figure 2-13**






3. Attach the flat hoop adapter bracket to the x-carriage using the proper fasteners. Make sure the slotted end of the adapter is facing to the right.
4. Along the x-carriage (behind the needle case) are the mounting locations for the flat hoops. The mounting brackets on the peripheral are spring-loaded, so insert the right side (as you are facing the machine) of the hoop's bracket first, then push slightly to the right (to move the spring-loaded bracket). Insert the left side of the hoop's bracket next. Refer to Figures 2-13 and 2-14.










**Push the hoop to the right (as you are facing the machine) then insert the left side of the hoop**

**Figure 2-14**




## Select a design

To select a design after it has been sent to the peripheral, press  until the display scrolls to DESIGN MENU. Press  and the first design is displayed. Use  to scroll forward or  to scroll backward through the designs in the buffer. Scroll through the menu until you reach the design you want. The LCD displays the name of the design, the stitch count, the number of colors in the design, and the current orientation that is selected. Press  to select the design; the LCD displays the next menu.

## Color Menu

To set the color sequence press  until the display shows COLOR MENU, then press . Press  to move to the next number and  to move back. Press  or  to change the needle position. Press  to select the color sequence; the LCD displays the next menu.




Press   to insert a color sequence and   to delete a color sequence.

### Available color choices:








- **1-10** = needle number - used to select needle order when sewing the design.
- **0** = pause for this color change only - the machine will stop sewing and continue on the same needle after the start button is pressed. Needle will change at the next color change in the design.
- **-** = skip this color change - used when the design has a color change in it, but the operator does not want to change needles. The machine will perform a trim and continue on the same needle.
- **P** = pause at this color change and all color changes thereafter. Used when running a design that has more color changes than needles. The machine will pause to allow the user to re-thread with a new color. Press start to continue sewing after each pause.
- **A** = stop for applique. The machine will perform a color change, then move the rack forward so the user can apply an applique. Press start to continue sewing.

## Run Menu

Press  to queue the design; the LCD displays the next idle menu.








## Trace the Design

Note: Do **NOT** pull the needle or presser foot down to trace.

Press  until the display reads: FUNCTION MENU, then press . Press  or  until the display shows **Trace design outline?**, then press . The LCD will display **Calculating design outline**. When the outline is calculated, it will display **Trace Design name** and show you the needle number. Press  to initiate the trace 

function and the pantograph will begin to move. The hoop moves along the outline of the design without embroidering. The machine beeps and displays **Rack Limit** if a rack limit is encountered. **The beep means the needle will strike the hoop if sewn.** To correct this, re-center the hoop, select and use a larger hoop, or manually jog the hoop into position. Perform another trace after you have corrected the problem.

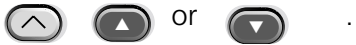
### Start Embroidering

After the tracing function is finished, press   to return to the idle menu again. Press  and the machine will move to the beginning of the design. Press  again and the peripheral will embroider the design selected (you may have to press  an additional time if the design began with a Needle Ups command). The embroidery will stop when the job is complete and the display reads: END OF DESIGN. To stop the embroidery process before the design is complete, press  on the keypad. To continue after a stop or thread break repair, press  again.






### Embroidery Speed

While the design is being embroidered you may change the speed of the machine by pressing



### Idle Display

While the machine is operating, you may press   at any time to see the Idle display. There are two screens available in the Idle display; press  to toggle between them.

The first display (Figure 2-15) shows the design name, the current sewing speed, the current orientation, and the current needle number.



Figure 2-15

The second display (Figure 2-16) shows the stitch count, the selected sewing speed, the needle number, and the percent complete.



Figure 2-16



**Important Tip:** If Machine sits idle or is not used for a longer period of time, the x-carriage should be “parked” outside of the sewing field. Move the rack to either side until it hits the mechanical stop. Before starting the machine or resuming sewing, move the x-carriage back to the center.



## 3. Accessories

### Conventional Cap Frames with Wide Angle Driver (Optional)

See addendum (part number 12160) shipped with the option.

#### Wide-angle cap frame

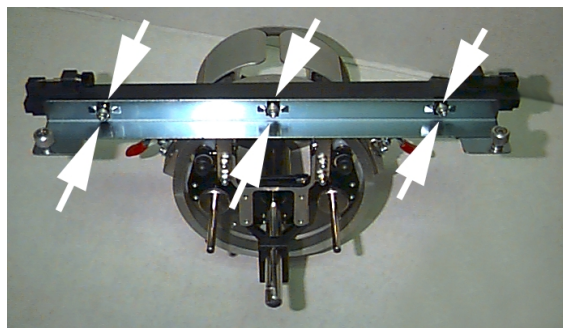
The Wide-angle cap frame option allows you to embroider on nearly 270° of a cap's crown and includes:

- The cap hoop(s)
- The cap frame driver(s)
- The cap frame gauge

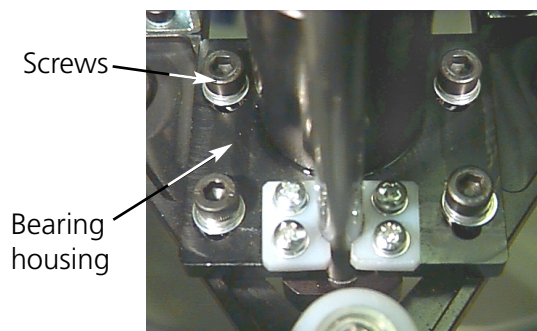
#### First time installation and adjustment

The first time you install the wide-angle cap frame driver on an EMT peripheral, you must perform the following adjustment; failure to do so will result in an excessive wear to the cap frame driver and reduced embroidery quality.

1. Remove or lower tabletop inserts. On the EMT 10/4 or 10/4T, you only need to remove or lower the 2 large tabletop sections.
2. Make sure that the cap supports are extended; if they are not, extend them (refer to the Technical manual for more information).
3. Make sure that the 3 socket-head cap screws along the interface bracket (Figure 3-1) and 4 socket-head cap screws which hold the bearing housing (Figure 3-2) are slightly loose.
4. Move the beam all the way back (towards the rear of the peripheral) using the peripheral keypad.

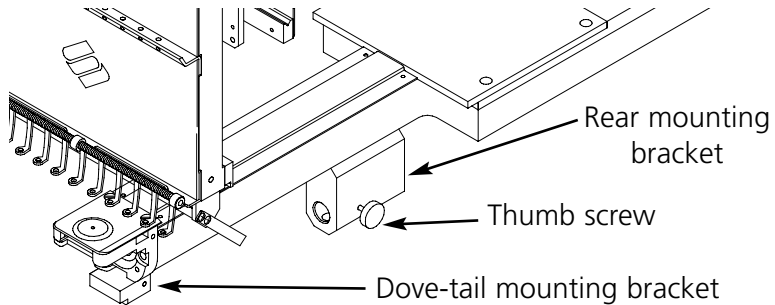


**Figure 3-1**



**Figure 3-2**

5. Install the driver; guide the cap driver shaft into the hole in the rear mounting bracket. At the same time, insert the driver dove-tail support bracket into the female dove-tail mounting bracket. Refer to Figure 3-3.



6. Push the cap driver shaft into the hole in the rear mounting bracket until it reaches the positive stop.

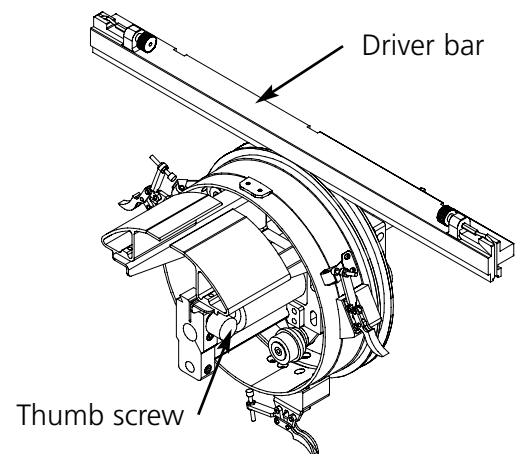
Note: When pushing the driver shaft into the hole in the rear mounting bracket, make sure the cap supports are positioned over the needle plate. This prevents the shaft from binding.

7. Tighten the thumb screws on the rear mounting bracket and on driver dove-tail support bracket (see Figure 3-4).

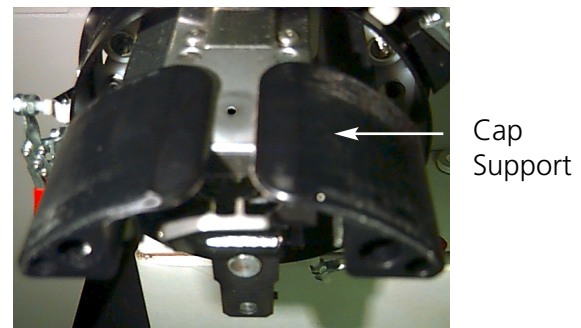
8. Position the driver cap supports on the needle plate (see Figure 3-5), center them to the needle plate hole and in the same time adjust their position in up-down direction by moving driver up-down on the slots in the bearing housing and slightly tighten at least one socket cap screw on the bearing housing using 4mm hex allen wrench. The cap supports should touch the needle plate lightly and the driver should slide freely from front to back without any restriction; the cap supports should not have any visible side to side movement.

9. Push on the driver bar to move the driver from front to back several times, making sure the driver moves freely. Tighten all 4 screws on the bearing housing.

**Figure 3-3**



**Figure 3-4**



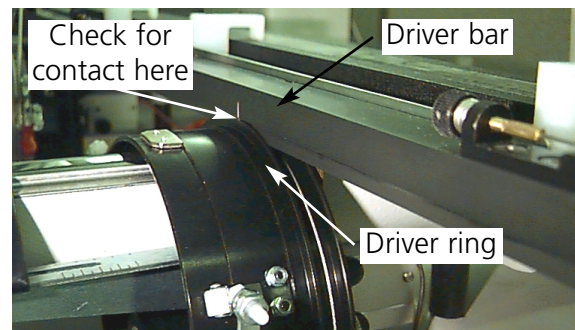
**Figure 3-5**

#### **Special note for the EMT 10/4 and 10/4T**





Apply the number sticker that is provided to the driver bar and to the head if it wasn't marked at the factory. The drivers should always be installed on the same head of the same peripheral they are adjusted on; when you install the drivers on the peripheral at a later date, make sure the numbers correspond. Repeat steps 2 through 9 for the remaining drivers.

10. Select Cap Frame Sewing and center the hoop.
11. Using the peripheral keypad, move the beam to the front of machine and connect the cap driver to the beam using the 2 proper fasteners on the x-carriage.
12. Tighten the 3 socket-head cap screws along the interface bracket until they barely contact the bracket using provided 3mm short arm hex allen wrench. The interface bracket should still be able to move in up-down direction. Refer to Figure 3-1 for screw locations.

13. Level the interface bracket. To do this, first move the beam all the way to the left, by pushing on the X-carriage. Make sure that there is no gap between the driver bar and driver ring (see Figure 3-6). If needed, press down lightly on the bar and tighten the corresponding socket-head cap screw on the interface bracket slightly. Then, by pushing on the X-carriage, move the beam all the way to the right and repeat the procedure.



**Figure 3-6**

14. Repeat moving the driver all the way to right and left, watching closely to ensure that the driver bar firmly contacts the driver ring and moves with no visible restriction. If the driver bar does not firmly contact the drive ring, loosen the 3 socket-head cap screws and repeat step 14.
15. Carefully and firmly tighten all 3 socket-head cap screws along the interface bracket without allowing the bracket to move.
16. Repeat steps 11 through 14 for the remaining drivers if necessary.
17. Press   to go to the Function menu then press  ; select **Go to Hoop Center?** and press .

Your wide-angle cap frame driver(s) are fully adjusted and ready for use.

### **IMPORTANT**

If you wish to use the adjusted cap frame option on a different peripheral, check the adjustment on the new peripheral to ensure proper sew quality.

This adjustment only needs to be performed the first time the cap frame driver is installed on a machine. **The Wide-angle cap frame does NOT require the use of raised needle plates.**





### Installing the wide-angle cap frame driver

The steps in this section describe how to install the driver after it has been previously installed and adjusted. If you have not installed the driver previously, refer to the First Time Installation and Adjustment section. To install the cap frame driver on an EMT peripheral, follow these steps:

1. Lower the table top to gain access to the cap frame driver mounting brackets under the head.

#### Special note for the EMT 10/4 and 10/4T

You **MUST** lower or remove the 2 large tabletop inserts before embroidering caps on the EMT 10/4 or 10/4T. Failure to do so may result in damage to the equipment or bodily injury. Refer to Chapter 1 for more information. Also, correlate the number on the driver with the number on the head to ensure sew quality.

2. The **Wide-angle cap frame** hoop size will be automatically selected.
3. Press   to go to the Function menu then press  ; select **Go to Hoop Center?** and press .

4. Under the cylinder arm, locate the cap frame mounting brackets (see Figure 3-7):

- The female dove-tail mounting bracket under the needle area
- The rear mounting bracket (with a round hole at the rear of the head)

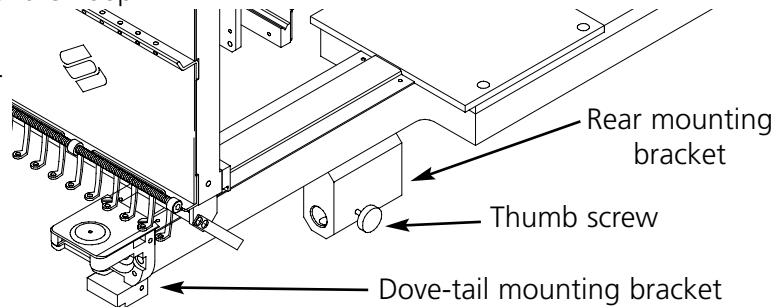


Figure 3-7

5. Loosen the thumb screw on the rear mounting bracket.
6. Loosen the thumb screw on the male dove tail bracket on cap frame driver (Figure 3-8).

Note: When pushing the driver shaft into the hole in the rear mounting bracket, make sure the cap supports are positioned over the needle plate. This prevents the shaft from binding.

7. Guide the cap driver shaft into the hole in the rear mounting bracket. At the same time, insert the male dove-tail bracket into the female dove-tail mounting bracket.

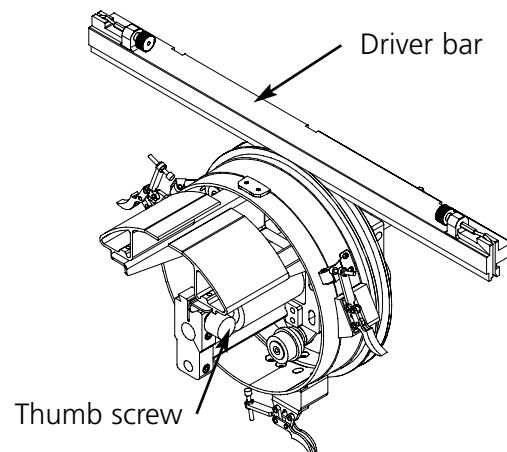


Figure 3-8



8. Connect the wide-angle cap frame driver to the x-carriage using the hoop interface proper fasteners on the x-carriage.
9. Push the cap frame driver shaft into the bracket hole as far as possible.
10. Tighten the thumb screw on the rear bracket.
11. Tighten the thumb screw on the male dove-tail bracket.

Note: The first time you install the wide-angle cap frame driver on the peripheral, perform the adjustment procedure in the previous section.

12. Repeat this procedure for each head on the EMT 10/4 or 10/4T.



Always install the driver on the mounting brackets first, and then attach the driver to the beam. This will improve the quality of your embroidery.

### The tensioner disk (optional)

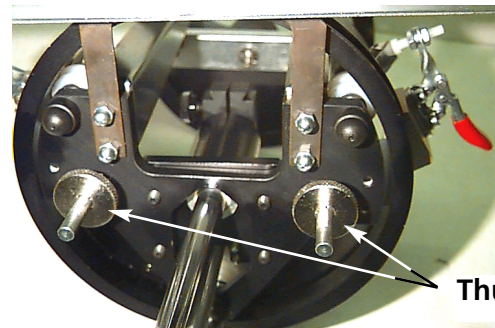
To install the tensioner disk, follow these steps:

1. Loosen the two thumb nuts on the back of the wide-angle cap frame driver (see Figure 3-9).
2. Insert the tensioner guides into the two holes in the front of the wide-angle cap frame driver (through the two thumb nuts on the rear).
3. Tighten the two thumb nuts.

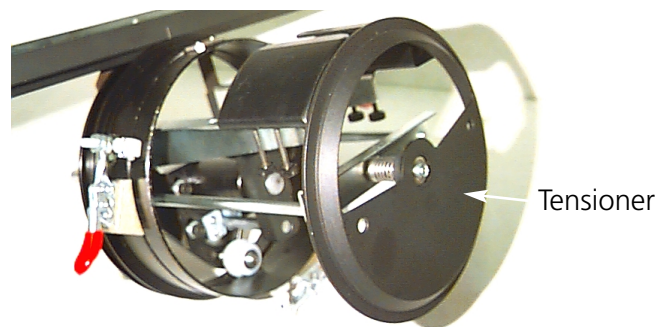
Figure 3-10 shows an installed tensioner.

Note: You may need to adjust the tensioner slightly to provide optimal tension for caps with different crown heights. Simply loosen the thumb nuts and slide the tensioner to its appropriate location, then retighten the thumb nuts.

Reverse these steps to remove the tensioner.



**Figure 3-9**



**Figure 3-10**

### The cap frame gauge

To install the cap frame gauge, tighten the clamp until the gauge is held firmly. Figure 3-11 shows a mounted cap frame gauge.

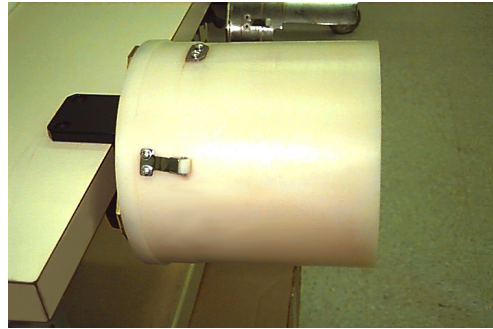


Figure 3-11

### Hooping with the wide-angle cap frame

Hooping on a wide-angle cap frame should be as straight-forward and simple as hooping on a regular cap frame. Follow the steps outlined below to hoop on your wide-angle cap frame:

1

First, attach the cap gauge to a stable surface.

2



The cap frame has a metal strap, with a buckle at its end. Make sure this buckle is attached by screws in its **OUTSIDE** two holes, **NOT** the inside two holes.

3



Now, slide the cap frame onto the gauge, making sure the locating element on the cap gauge fits into the cap frame's notch, and the cap frame slips firmly under the two roller clips.

4



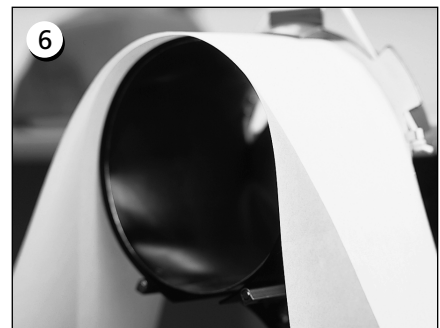
For the best sew quality, use the rubber strip; it provides appropriate spacing and hoop tension. Drape the strip over the gauge...

5



...placing the ends **BETWEEN** these clip posts and the cap gauge.

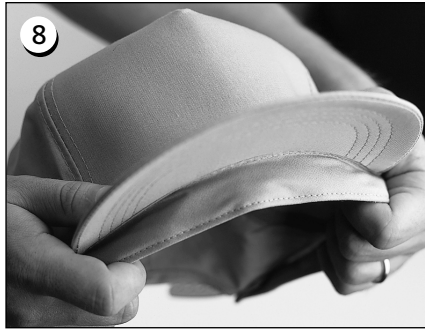
6



Appropriate backing can now be placed around the rubber strip. The backing stays **OUTSIDE** the posts and is pushed **BENEATH** the locator. You may use several layers of backing.



Next, prepare the cap for sewing. Open the back fastener.



Lower the sweatband completely.



If the cap has a braid, move it around the cap to the inside and under the brim as shown.



If the braid has a tail on the inside, trim it short to keep it clear of embroidery. Leave only about 1/4" of braid from where it's sewn to the cap.



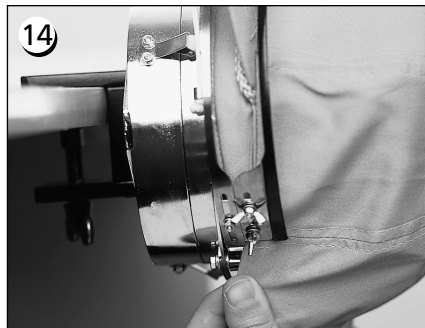
Now place the cap on the cap frame. The sweatband should be under the locator, and the brim should be centered and pointing up.



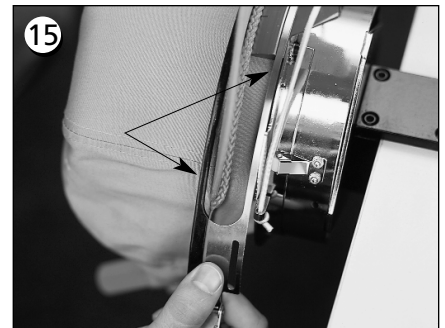
Pull the side of the sweatband toward the cap frame and down.



Flatten any "bunching" of the sweatband by folding it over and toward the hoop.



To secure the sweatband, swing the metal strap up and over the sweatband and the cap's brim.



Close the metal strap, making sure one band of the strap fits in the groove on the locator...and the other band lies cleanly along the brim edge.

16

To achieve a snug fit of the cap frame's metal straps, perform step 17 whenever you change cap styles.

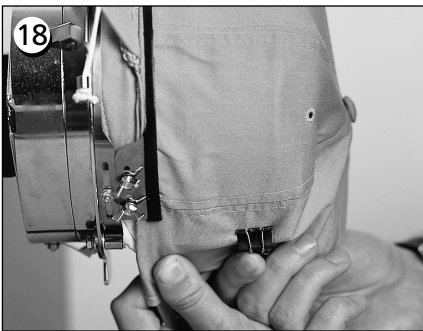
Step 17 does not need to be performed if the cap style has not changed. In this case, simply latch and close the buckle.

17



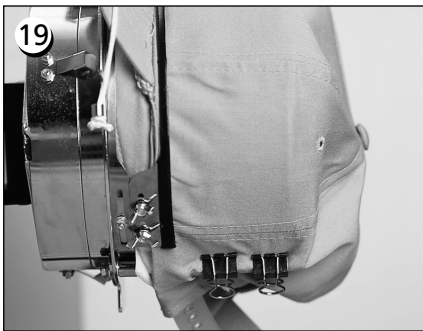
Loosen the wing nuts on the strap, latch and close the buckle...then push down on the strap above the wing nuts with a hard tool. Use MODERATE pressure when doing this. Retighten the wing nuts.

18



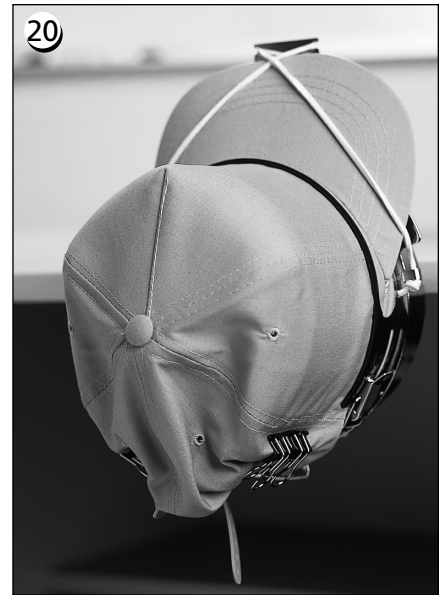
Pull the elastic brim holders over the cap's brim to the front. Pull the wrinkles out of the cap using light tension. To secure the cap fabric, attach two clips...

19



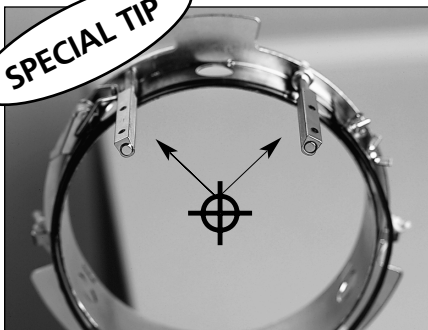
...to each post. The clips are applied with the handles angled down and toward the center of the cap.

20

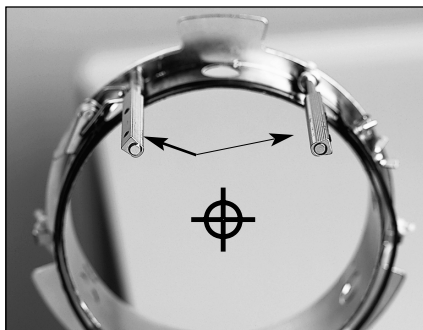


You may now remove the cap hoop from the gauge. Remember to also remove the rubber strip. Your cap is now properly hooped.

**SPECIAL TIP**



Make sure the posts are aligned properly with the center of the cap frame.



If they look like this, readjust them.



If the posts are bent and touching the cap gauge, bend them back into position.

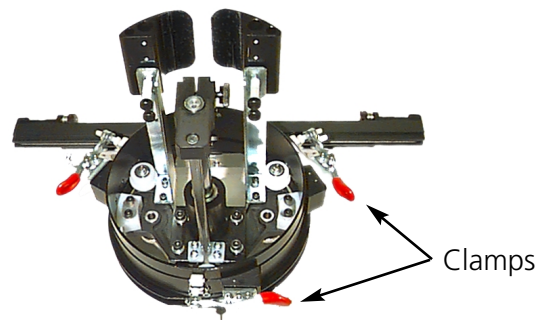
This is how they should look!

### Place the hooped cap on the driver

Unclip the 3 clamps on the cap frame driver (see Figure 3-12). Slide the frame onto the driver, snapping it into place. Secure the 3 clamps on the driver.



Check the bobbin thread before you install the frame with a cap attached; if you run out of bobbin thread you must remove the cap frame in order to change the bobbin. This may result in lost registration.



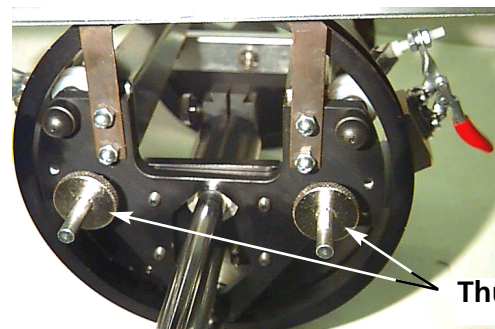
**Figure 3-12**

### Using the tensioner disk (optional)

The tensioner disk attaches to the cap frame driver and increases tension in the crown of the cap during embroidery. This additional tension helps improve embroidery quality, particularly on non-structured caps. The tensioner disk also increases embroidery quality on slouch and short-crowned caps, but because the tensioner disk reduces the embroidery field's height by approximately 0.23in (6mm) you may not be able to use the tensioner disk without modifying the design to reduce overall height.

If you try to use the tensioner disk without compensating for the height of the design, you will see reduced embroidery quality near the top of the design. The tensioner disk will contact the needle plate and prevent the beam from moving as far as is needed for the design height.

The tensioner disk needs to be adjusted differently for each type of cap used on your peripheral. To adjust the tensioner disk, simply loosen the thumb nuts and slide the tensioner disk in or out, then retighten the thumb nuts (see Figure 3-13). The disk should push the crown of the cap out slightly (increasing the tension). There is not a "rule of adjustment" because of the variety of caps available today.



**Figure 3-13**

Do not adjust the tensioner disk to fit so tightly that the spring (pushing the disk out) is completely compressed. If you do, the tensioner disk may restrict the cap's movement during embroidery, resulting in a loss of registration and reduced embroidery quality.

### Sewing field

The height of the sewing field varies on caps because of the variation in crown sizes. You can use the following formulas to calculate the height of the sewing field for different crown sizes:

$$Y=A - 1.18$$

$$X=14.25"$$

Where:

**Y**= height of the sewing field in inches

**A**=height of the crown in inches

$$Y=A - 30$$

$$X=362\text{mm}$$

Where:

**Y**= height of the sewing field in millimeters

**A**=height of the crown in millimeters



Remember, if you are planning to use the tensioner it reduces the embroidery field's height by approximately 0.23in (6mm).

**Tip**

## Cap designs

Designs that embroider well on flats may not embroider as well on caps because of the uneven tension a cap frame provides. Here are some ideas to help improve embroidery quality on your wide-angle cap frame:

- To help eliminate slippage, digitize from the center out; start in the center of the design and embroider one side of the cap then return to the center and embroider the other.
- Complete entire design elements as you go around the side; for example, if you have lettering with shading, embroider a letter, then its shading, then move on. This helps to eliminate the push-pull tendency of the fabric of the cap. Underlays should follow this rule, too.
- If you have a lot of running stitches in a design, consider converting them to satin stitches. Running stitches have a tendency to lose registration.
- With large designs, try to alternate the direction of the stitches. This helps to eliminate the push-pull tendency of the fabric of the cap.
- Use more underlay stitches to help stabilize the design and prevent distortion. Six panel caps need more underlay in the center where the seam is.
- Using a fusible non-woven backing on six panel caps helps hold the two front panels firmly together.

Modifying your designs to embroider on caps may give you more trims and color changes, but it will also provide you with much better embroidery quality.

## The Sash Frame

The sash frame is an aluminum rectangle that attaches across the full length of the x-carriage, using the table tops for support. The material is held in place by fabric clips included with the sash frame. The sash frame has a maximum embroidery field per head of 11.02" x 16" (28cm x 40.6cm) for the EMT 10/4 or 10/4T and 11.02" x 19.69" (28cm x 50cm) for the EMT 10T F1.

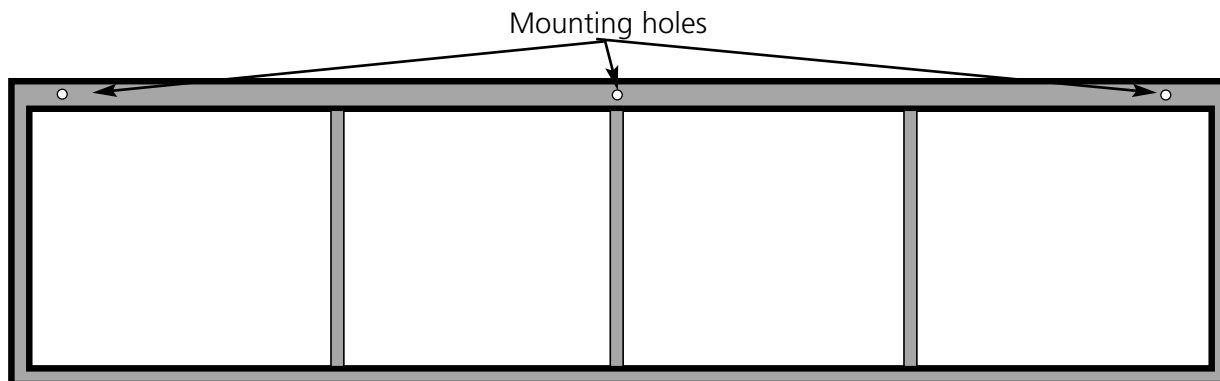
Often, only the backing material is hooped in the sash frame, and several smaller pieces of fabric are fixed on top of the backing with a non-permanent fabric adhesive. This procedure reduces hooping time and permits a high rate of production on parts of preassembled garments like labels, patches, collars, and pockets.

## Installing the Sash Frame

Follow these instructions and see Figure 3-14.

1. Before installing the sash frame, **make sure the table tops are in place**. Without the support of the table tops, the sash frame may be damaged.
2. Guide the sash frame under the head(s) with the mounting holes toward the x-carriage.
3. Match the sash frame mounting holes with the proper fasteners on the x-carriage. On the EMT 10T F1 start with either the left or right fastener, tighten both of them. Next, move the sash frame to the left or right in order to gain access to the center fastener.
4. Tighten the screws when they are all in place.

(Sash Frame for the EMT 10/4 shown)



**Figure 3-14**



### Storing the Sash Frame

The sash frame will not operate properly if it is bent. Suspend the frame lengthwise when not in use.

### Hoop Selection

Before embroidering with the sash frame, **Select Hoop** in the Options Menu to either the sash frame or a spider hoop (if appropriate). Failure to do so may damage the peripheral.

### Hooping on the Sash Frame

The same hooping guidelines apply to the sash frame as to regular hooping.

1. Lay the fabric over the sash frame as flat as possible.
2. Attach the first clip on the x-carriage side of the frame near a corner. The thumb rail should be facing away from the embroidery field.
3. Attach 6 of the 300cm clips along the **back** of the frame on the EMT 10/4 or 10/4T; use 1-220cm clip and 1-300cm clip along the **back** of the frame on the EMT 10T F1.
4. Pull the fabric taut and attach the same number of clips at the **front** of the frame.
5. Attach one 220cm clip to **each end** of the frame on the EMT 10/4 or 10/4T and one 220cm clip to **each end** of the frame on the EMT 10T F1.

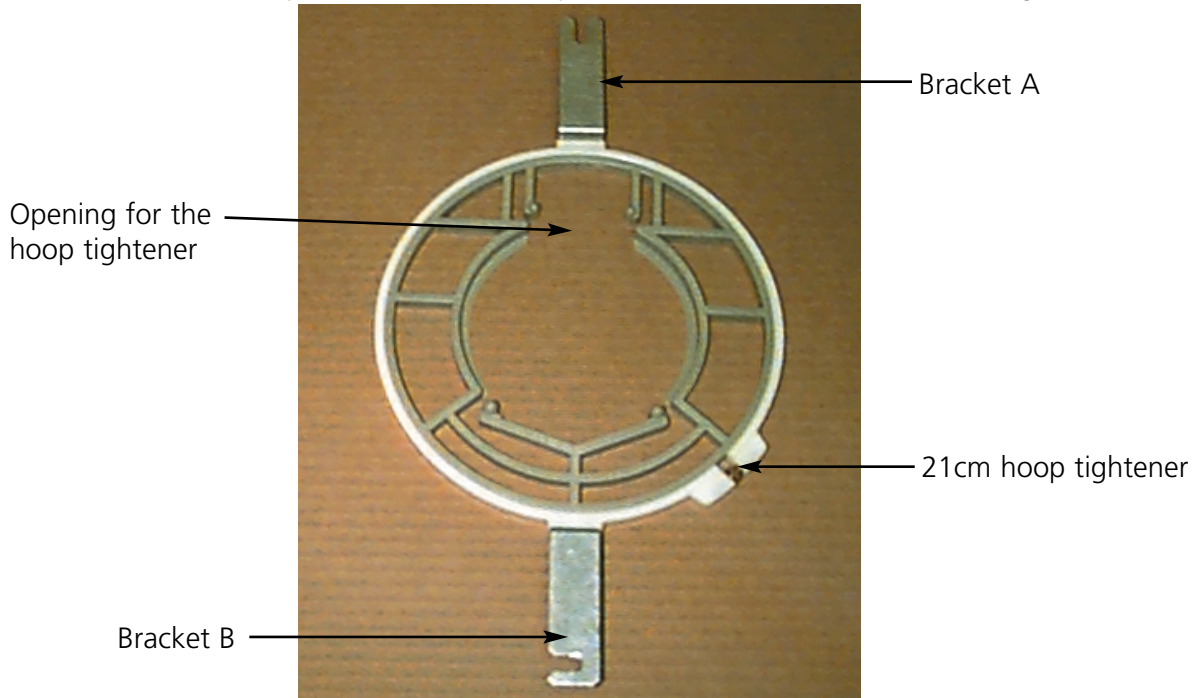
### Spider Hoops

A spider is a hoop that holds another hoop. Spider hoops attach to the peripheral and allow garments to be hooped individually without removing the frame. The outermost hoop has brackets that attach to the beam

There are two spider hoop options available. One option attaches to the sash frame, and one option attaches to the peripheral the same way a flat hoop does.

**To install spider hoops on the sash frame:**

1. Attach the thumb screws for the spider hoop into the sash frame, but do not tighten yet.
2. Remove the inner hoop from the 21cm hoop with the two brackets (shown in Figure 3-15).



**Figure 3-15**

3. Insert the spider hoop you plan to use so that the opening in the spider for the hoop tightener is centered on the bracket with the back-facing slot (Bracket A in Figure 3-15). Secure the spider with the 21cm hoop tightener.
4. Referring to Figure 3-15, slide bracket A into place on the thumb screw at the rear of the sash frame, then swing bracket B into place on the thumb screw at the front of the sash frame.
5. Tighten the thumb screws.
6. Repeat for all embroidery heads on the EMT 10/4 or 10/4T.

Note: After using the spider hoops and BEFORE embroidering with the full sash frame (no spider hoops attached) remove the thumb screws or the machine may be damaged.

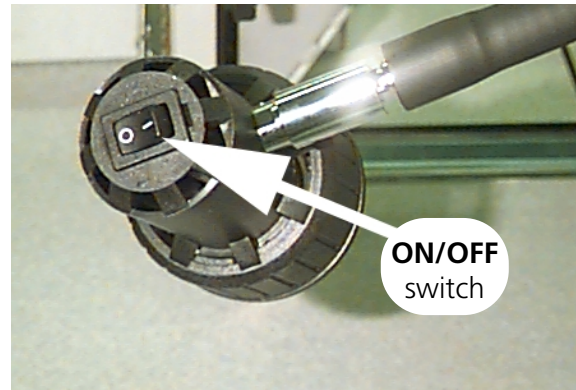


## Lamps

### EMT 10T F1

The EMT 10 comes with a flexible lamp attached to the table. The lamp has a separate ON/OFF switch located on the bulb case (Figure 3-16). Push to turn the lamp ON or OFF.

To change the bulb, turn the power off, then unscrew the bulb case (refer to Figure 3-16). Use a replacement bulb from Melco (one is provided in the operator kit).

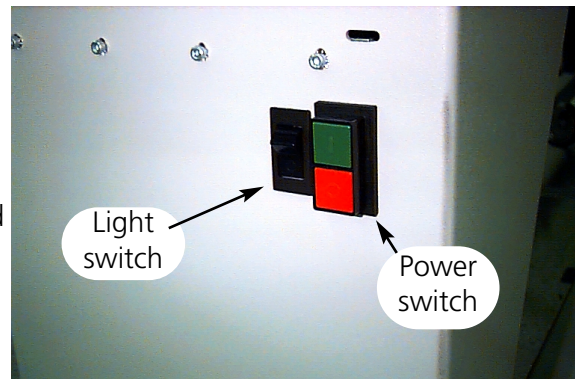


**Figure 3-16**

### EMT 10/4 or 10/4T

The EMT 10/4 has built-in fluorescent lights above the table. The lights have a separate ON/OFF switch located next to the main power switch (see Figure 3-17). Push to turn the lamp ON or OFF.

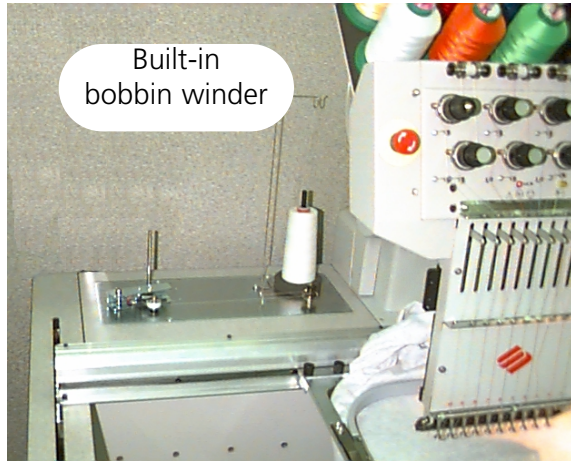
To change the bulb, turn the power off, twist the old bulb slightly, then remove. Align the contacts on the new bulb with the contacts on the machine. Insert the new bulb and twist into place. Use a 3' 25W fluorescent bulb (Melco part number 010394-01).



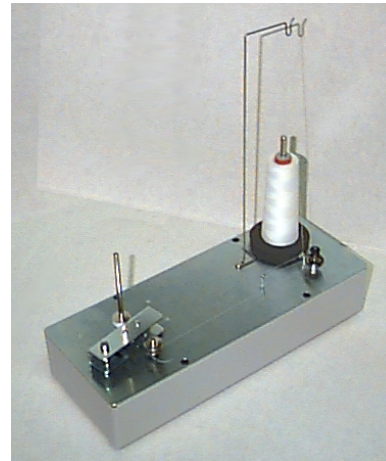
**Figure 3-17**

## Bobbin Winder

The Bobbin Winder is available in two basic configurations: as a built in feature of the EMT 10T F1 and as a stand-alone option. See Figures 3-18 and 3-19.



**Figure 3-18**



**Figure 3-19**

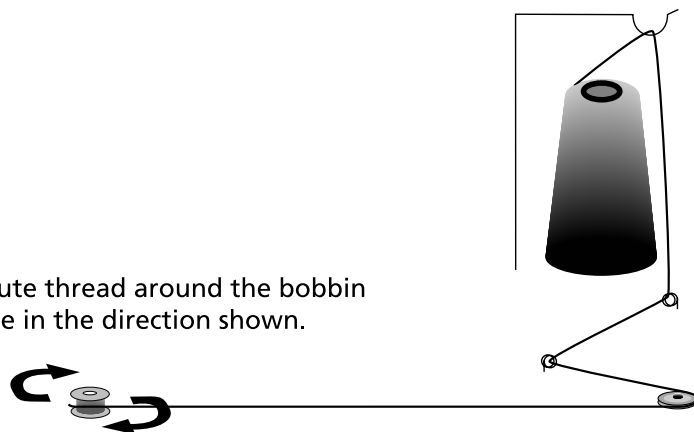
## Thread Selection

Although all standard embroidery threads may be used as an under or bobbin thread, embroidery results vary depending on the thread weight and composition selected. Thin, weak threads will increase thread breakage problems. Conversely, thick, slick-finish threads may produce problems with the stitch quality of finished embroidery. Bobbin tension requires adjustment for good embroidery with any thread. The weight of the thread selected and the tension used when winding will also determine the amount of thread on the bobbin and therefore the frequency of bobbin changes. For most applications, a cotton thread or a core spun cotton composition thread (such as RASANT) in a 40 or 50 weight (DTEX numbers 135x2 and 128x2 respectively) is recommended.

## Operation

1. Thread the winder as shown in Figure 3-20. The arrows on the base plate indicate the direction of the thread path.

Route thread around the bobbin case in the direction shown.

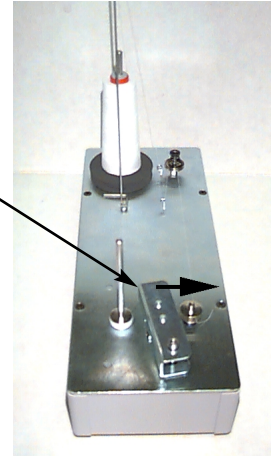


**Figure 3-20**

2. Place an empty bobbin spool (P/N 008499-01) on the winder shaft and make 6-8 tight wraps of thread around the spool in the direction shown. Break or trim off the thread tail close to the spool.
3. Move the actuator lever to the ON position (see Figure 3-21) and winding will begin. The winder automatically stops when the bobbin is wound completely.

Note: To set the level of fill, adjust the position of the Bobbin Full switch on the actuator lever using the two screws on top of the lever. The level of fill should be set to approximately 80% of the bobbin capacity or about 0.04" [1mm] below the edge of the spool flange.

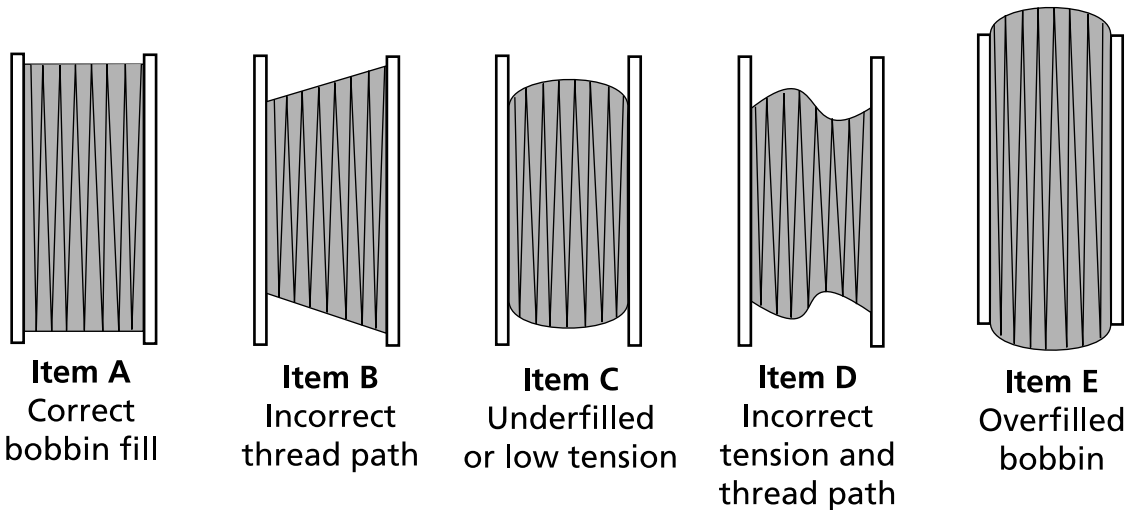
**Actuator lever**  
Move in the direction indicated



**Figure 3-21**

4. Move the actuator lever to the OFF position, remove the wound bobbin and break or trim the thread tail.

A properly wound bobbin is shown in Figure 3-22 (item A). Items B through E in Figure 3-22 show improperly wound bobbins. Adjust the winder tension, the thread path or the Bobbin Full switch to correct winder operation if you are experiencing any of the situations shown below.

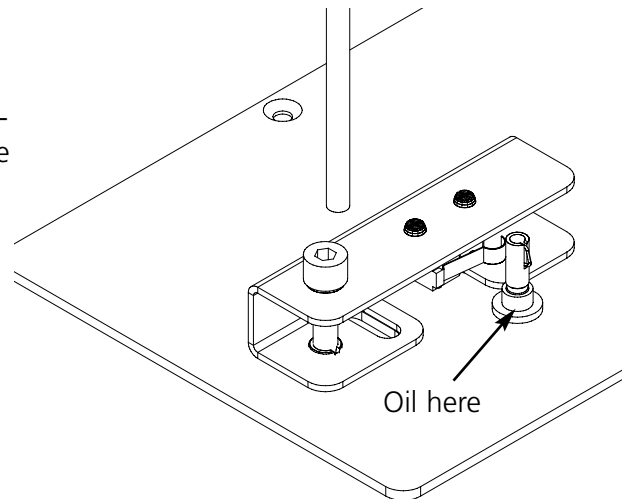


**Figure 3-22**

### Motor Protection

The bobbin winder motor is equipped with a thermal switch to protect the motor and drive circuitry in the event of an overload condition. If the bobbin winder stops due to an overload follow these steps to correct the problem:

1. Move the actuator lever to the OFF position.
2. Clear the obstruction and lubricate the drive shaft (refer to Figure 3-23).
3. When the motor cools, the thermal switch will automatically reset.
4. Move the actuator lever to the ON position to resume operation.

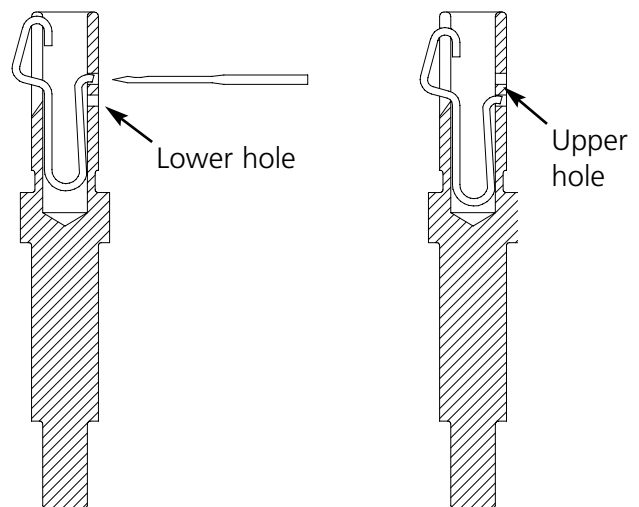


**Figure 3-23**

### Bobbins

The bobbin winder is designed for use with the aluminum bobbin spool (p/n 008499-01) provided with the unit. If bobbin spools from other sources are used, the bobbin may be improperly retained on the bobbin winder shaft. Most non-standard bobbin spools have a slot in the spool hub that engages the bobbin winder shaft spring and holds the bobbin in place. If this type of bobbin spool is used, you must reposition the shaft spring. Refer to Figure 3-24 and follow the steps below:

1. Use a needle to disengage the spring from the standard (upper) hole in the shaft.
2. Slide the spring into the shaft until the spring tail snaps into the second (lower) retaining hole.
3. This is the operating position for slotted hub bobbin spools.



**Figure 3-24**

### Bobbin Winder Maintenance

When the bobbin winder is subjected to heavy or continuous operation, you may need to lubricate the bobbin winder shaft. Apply one drop of sewing machine oil to the bobbin winder shaft as shown in Figure 3-25. Rotate the bobbin winder shaft by hand until the shaft moves smoothly and freely.

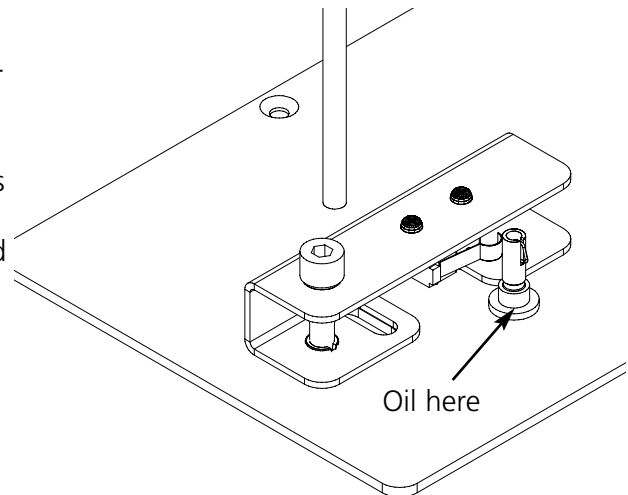


Figure 3-25





## 4. Operator Maintenance

This chapter outlines machine maintenance; in addition, operators and maintenance personnel must attend a Melco approved training course prior to maintaining the machine.

### Installing a Needle

Each needle has a needle clamp set screw holding it in place as shown in Figure 4-1. Use the small flat-blade screw driver from the tool kit and follow these steps to replace a needle:

1. Turn the set screw counterclockwise until the needle can slide down and out of the needle bar. Do not remove the set screw.
2. With the scarf of the new needle toward the rear of the head, slide the needle into the needle bar as far as it will go, and re-tighten the set screw. The eye of the needle should be facing directly forward.

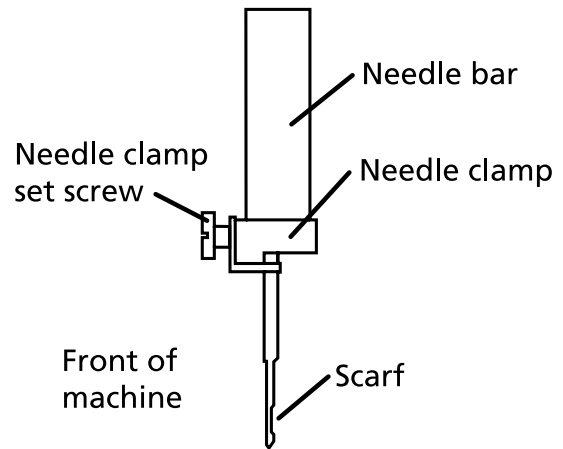


Figure 4-1

### Thread Break Switch

Each head has a thread break switch below the tensioners with

△ (ON), ∞ (AUTO), and ▽ (OFF) positions (see Figure 4-2). The switch controls whether the individual head stitches as it moves through a design. The table below summarizes the functions of the switch.

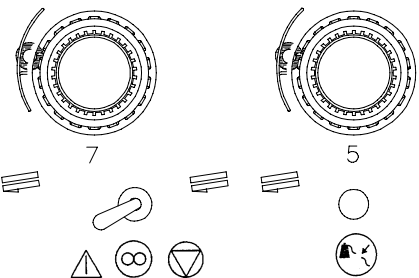


Figure 4-2

SETTING	FUNCTION
△	Sews during thread break and framing recovery. Use to restitch an area.
∞	Only heads with thread breaks will sew during thread break recovery or framing. Should be used for normal operation.
▽	Disables the sewing head.

## Thread Break Indicator LED

Next to each Thread Break Switch is an LED that signals a thread break (refer to Figure 4-2). When a thread break is detected, the LED on that head will be illuminated. A blinking LED indicates an under-thread break while a steadily glowing LED indicates an upper-thread break.

## Cleaning

### Work area

The work area around your peripheral should be kept orderly and clutter-free at all times.

### Exterior Surfaces

Clean outer plastic surfaces once per month with a soft, clean cloth, a mild detergent and water. Wring out the cloth before wiping the surfaces. Do not get water or any other fluids inside the machine or on any of the working mechanical surfaces.




Note: If an accidental spill occurs, wipe it up immediately with a clean dry cloth and allow the machine to dry completely before turning the power on.

### The Rotary Hook Area



1. Clean this area once per month with the machine power OFF.
2. Remove the 2 needle plate screws and lift off the needle plate.
3. Clean the exposed area with the brush supplied in the operator kit, or use compressed air to blow any debris from the area.

Note: Depending on the type of material being used, this area may require cleaning more often. Some high-lint materials will require this area to be cleaned once per day for peak performance.

## Lubrication

The EMT 10T F1, 10/4, and 10/4T require regular maintenance to perform their best. A message will display at the end of each design when it is time for maintenance. Press   to enter the Service/Maintenance menus (HEAD TIMING MENU will be displayed). Press  to scroll to the required menu to perform the maintenance. Any necessary tools are provided in the operator kit. You can use a light-duty sewing oil (available from Accessory Resource Corporation) to lubricate your peripheral; a small bottle is provided in the operator kit.

Note: Before you perform any lubrication on the peripheral, you should remove all garments from the machine. Also, for every lubrication menu **except the 8 hour menu** you should remove the hoops; the eight hour menu moves the cap frame driver to distribute the oil, so it must be attached to the peripheral. And because the maintenance program requires rack movement in most menus, your current start position will be lost.




Press  to step through the menu. Each time you press , the machine will move to its next position. Refer to these pages to oil each component throughout the process. When you have completely stepped through each menu, the display will be cleared.

The message will display at the end of each design. You can press any key to temporarily clear the message, but you must perform the required maintenance to clear the message (until the maintenance is required again). Use the oil provided in the operator kit.

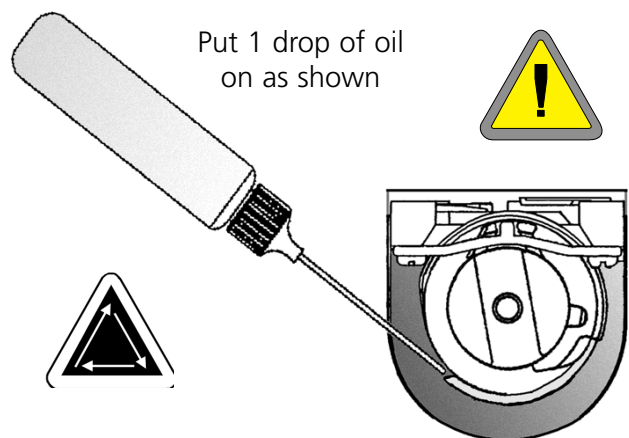
Due to software limitations, you may experience multiple lubrication messages for different lubrication intervals. For example, you may perform the 40 hour maintenance, sew a design, and have to perform the 80 hour maintenance. The reason for this is that the counter, which logs the time for each message, is not reset until you perform the maintenance.

Refer to this section for lubrication information. Follow the steps outlined below for each message.

### ***Time to oil hook***

When this message appears, go into the **4 hour lubrication menu** and press . When **hook** appears, press . This causes the z axis to move the hook to its proper position for oiling (250°). Refer to Figure 4-3 to lubricate the hook. Press  when done.






You must perform this operation to clear the message.



**Figure 4-3**

### 8hr maintenance due

This time will only accumulate when a cap frame is in use. You must perform this operation to clear the message. You may leave the driver attached to the peripheral to perform these maintenance steps.

If you are using a Large or Small Cap Frame, go into the **8 hour lubrication menu** then press . Press  or  until **cap driver shaft** appears, then press . This causes the y axis beam to move the cap frame to the correct position for oiling. Use 1 drop of oil on each side of the shaft (refer to Figure 4-4 to lubricate the cap frame driver shaft). Press  when done. The y-rail will move back and forth to distribute the oil.

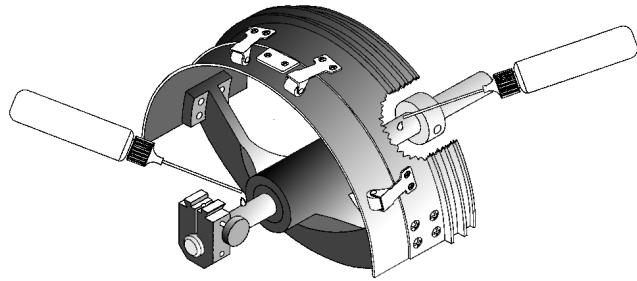








Figure 4-4



If you are using a Wide-Angle Cap Frame, go into the **8 hour lubrication menu** then press . Press  or  until **wide-angle driver shaft guide** appears, then press ; the x-carriage will move to the front. Wipe the lint off both driver shafts (see Figure 4-5). Place one drop of oil on the Driver shaft guide (the bottom shaft) as close to the cap frame driver as possible, then press  to move the x-carriage to the rear. Wipe the lint off both shafts. Place one drop of oil on the driver shaft guide at the plastic pad (see Figure 4-6). Press  when done. The x-carriage will move back and forth to distribute the oil.

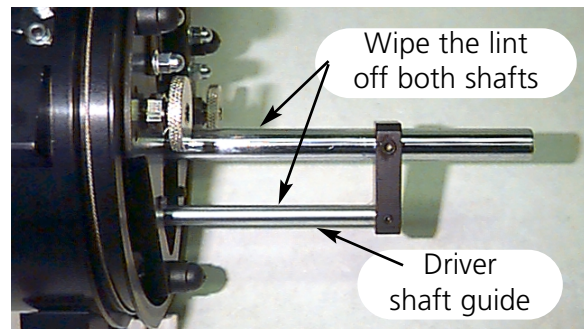


Figure 4-5

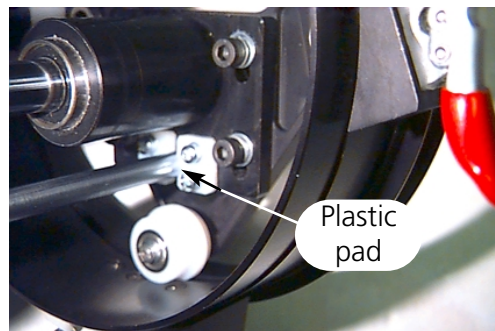




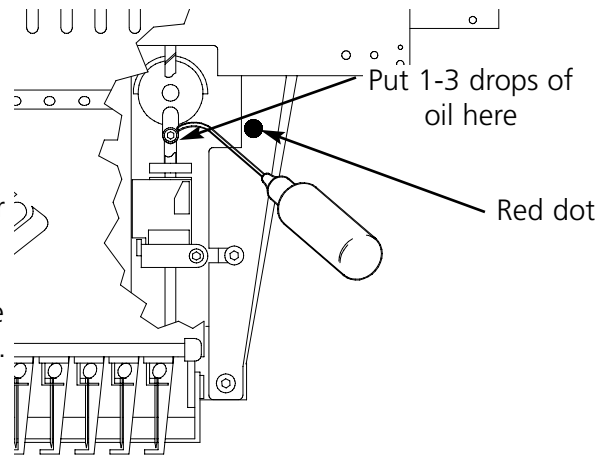
Figure 4-6


**40hr maintenance due**

When this message appears, go into the **40 hour lubrication menu**, then press 



When **upper connecting rod** displays, press . This moves the needle case to its proper position for oiling (needle 1 and 180° of z axis). Figure 4-7 shows the lubrication hole inside the machine. Insert the oiler through the square hole next to the red dot on the right side of the head. Press  when done.

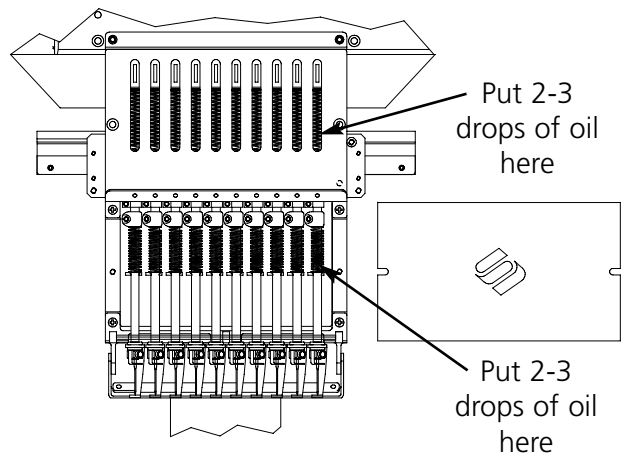
You must perform this operation to clear the message.




**Figure 4-7****80hr maintenance due**

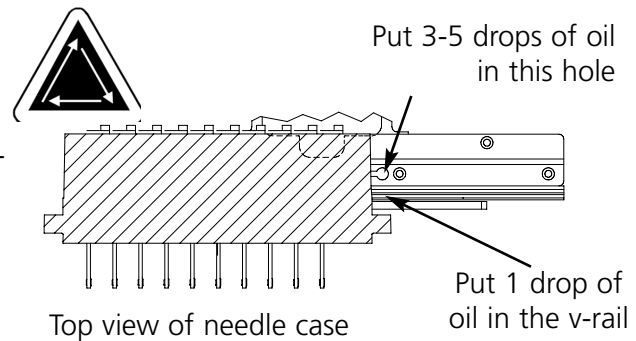
When this message appears, go into the **80 hour lubrication menu**, then press . Refer to the steps below to lubricate each area.

Note: If you have a cap frame driver attached, you must remove it before stepping through this menu.

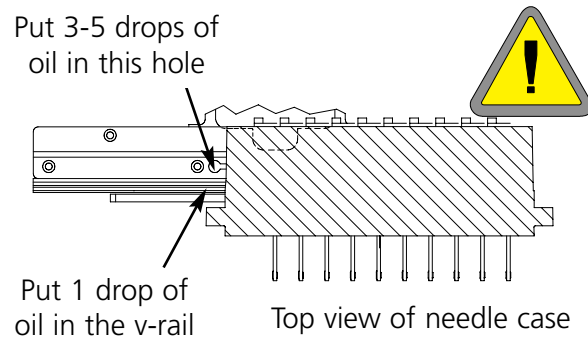
1. When **upper/lower needle bar** displays, press . No motion is required. Refer to Figure 4-8 to lubricate the upper and lower needle bars. Lubricate the needle bars for all ten needles. Press  when done.

**Figure 4-8**



2. When **needle bar driver/v-rail** displays, press . This moves the needle case to its first position for oiling (needle 1). Refer to Figure 4-9 to lubricate the needle bar driver at needle 1. Also refer to Figure 4-9 to lubricate the v-rail. Put the oil in the v-rail as close to the needle case as possible. To access these areas on the EMT 10/4 or 10/4T, insert the oiler through the hole with the red bushing on the front of the panel. Use a flashlight if needed. Press  to move the needle case to needle 10. Oil the needle bar driver as shown in Figure 4-10. Also, lubricate the v-rail on this side of the head. Press  when done. The head will move back and forth to distribute the oil.



**Figure 4-9**



**Figure 4-10**

3. When **lower connecting rod** displays, press . This moves the needle case to its proper position for oiling (needle 10, 150° of z axis). Refer to Figure 4-11 to lubricate the lower connecting rod. Use a flashlight if needed. Press  when done.

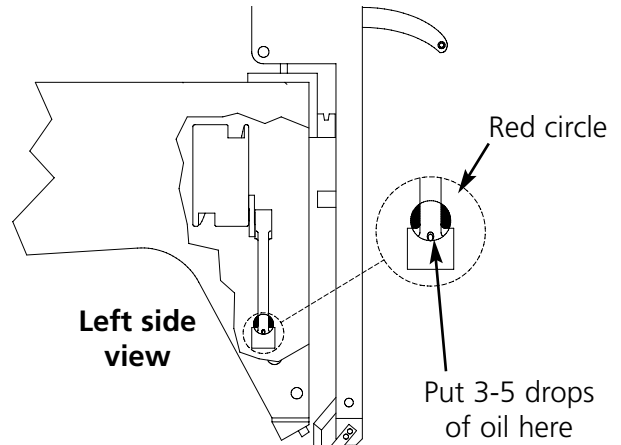
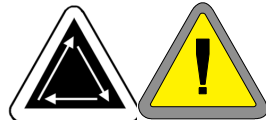




Figure 4-11

4. When **y-rails** is displayed, press . This moves the y-rail into its proper position for oiling. Refer to Figure 4-12 to lubricate the y-rail. Press  when done (the y-rail will move back and forth to distribute the oil). The y-rails on the EMT 10T F1 are not located directly under the slot. you must angle the oiler slightly toward the middle of the machine to reach the rails. Figure 4-13 shows the location of the rails (with the side panel removed).

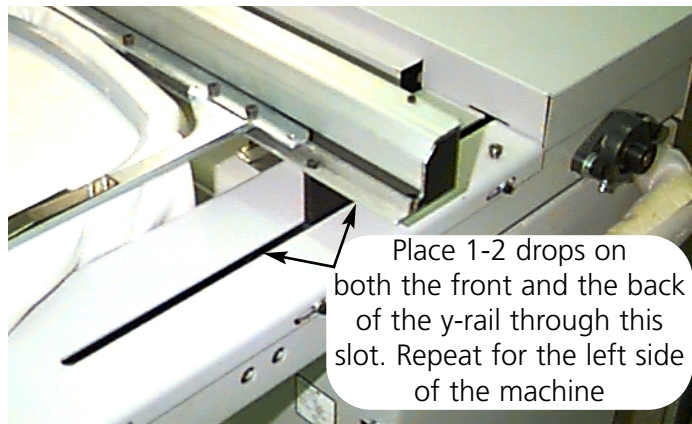


Figure 4-12

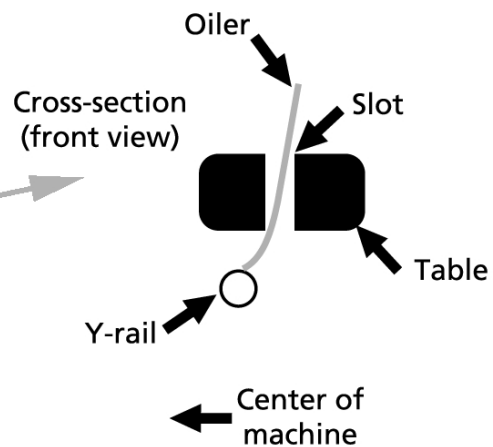
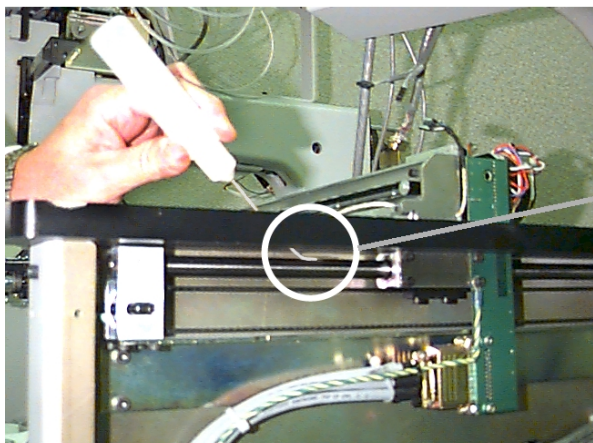




Figure 4-13

5. When **moveable frame, knife arm rear pin** displays, press . This moves the x/y axis to hoop center. Remove the rear bed cover (Figure 4-14). Refer to Figure 4-15 to lubricate the trimmer moveable frame and knife arm rear pin. Press  when done. Replace the rear bed cover.

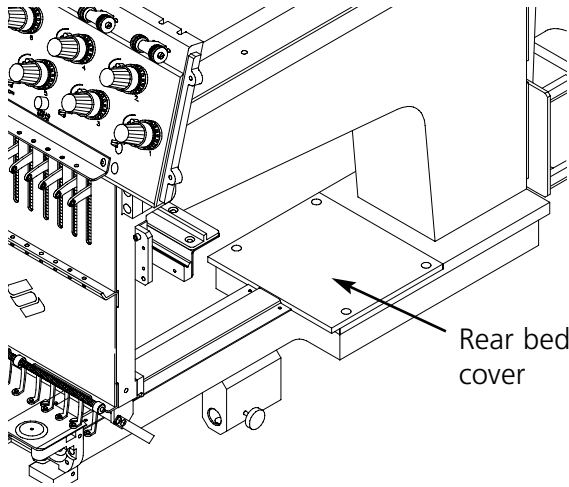


Figure 4-14

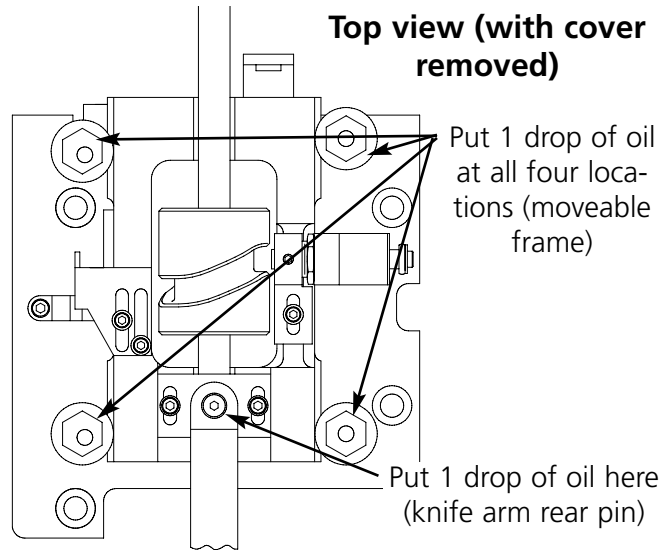




Figure 4-15

6. When **trimmer knife drive arm, front pin** displays, press . No motion is required to lubricate the trimmer knife drive arm and pin. Remove the needle plate. Refer to Figure 4-16 to lubricate the trimmer knife drive arm and pin. Press  when done. Replace the needle plate.

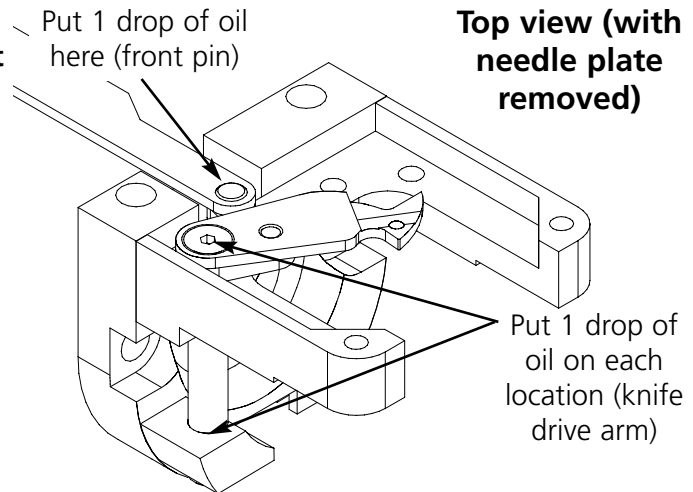




Figure 4-16



7. When **trimmer picker base shaft, rod pivot** displays, press . No motion is required to lubricate the trimmer picker base shaft and rod pivot. Refer to Figure 4-17 to lubricate the trimmer picker base shaft and rod pivot. Press  when done. The picker will cycle in and out.

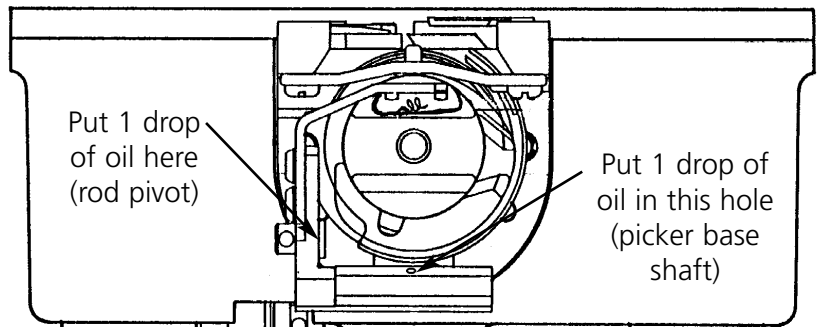




Figure 4-17

If your peripheral is not equipped with trimmers, you do not have to perform steps 5, 6, or 7. This completes the 80 hour maintenance. You must perform ALL operations to clear the message.

**480hr maintenance due**

When this message appears, go into the **480 hour lubrication menu**, then press . When **x axis** displays, press . This causes the x beam to move to the correct position for oiling. Before you can oil the linear rail, you must remove the aluminum cover; there are 9 screws along the top of the cover. Remove all 9 screws, then remove the cover from the x-beam.

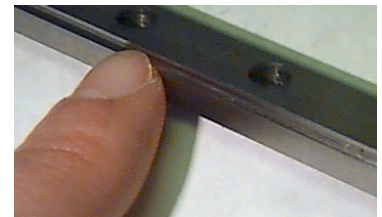


Figure 4-18

The linear rail is a metal beam with a groove along the front and back (along the top edge). When you oil the linear rail, make sure you put one drop of oil in the groove on each side of the metal beam. Figure 4-18 shows the groove along the front of the linear rail; there is another groove on the back side of this beam.

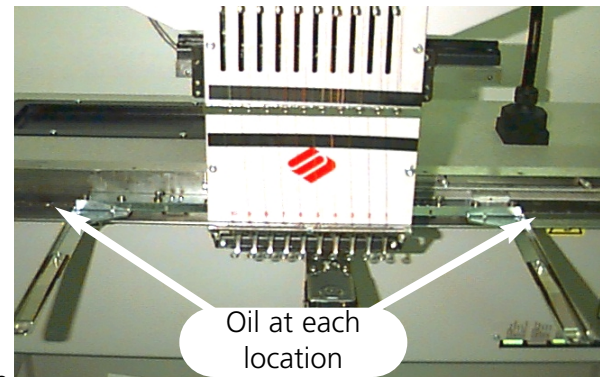



Figure 4-19

On F1 machines you do not have to remove the covers because the opening between the cover and the beam on the front side of the machine is large enough to oil the front groove. The rear groove cannot be reached this way, but users can put a drop of oil on the point where the back edge of the rail and the carriage "meet." The oil will run down into the groove on the backside of the rail.

Refer to Figure 4-19 to lubricate the linear rail on an EMT 10T F1.

Refer to Figure 4-20 to lubricate the linear rail on an EMT 10/4 or 10/4T.

Replace the cover on the x-beam.

Press  when done. The x-beam will move back and forth to distribute the oil.

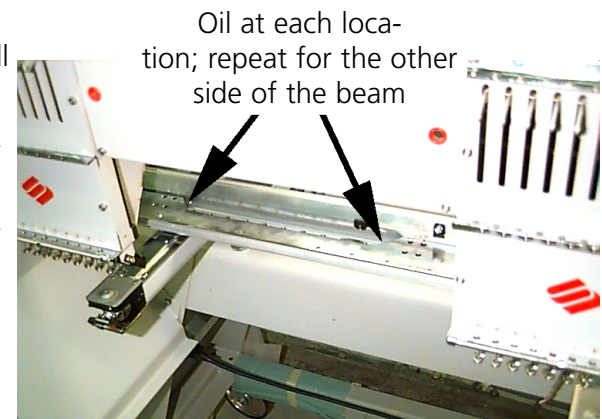





Figure 4-20



### 2100hr maintenance due

When this message appears, go into the **2100 hour lubrication menu**, then press . Refer to the steps below to lubricate each area.

1. When **color change cam** displays, press . This causes the needle case to move to needle 10. Refer to Figure 4-21 to lubricate the color change cam; USE A SMALL AMOUNT OF GREASE to lubricate the color change cam pins. Press  when done (the machine will perform a series of color changes to distribute the grease).

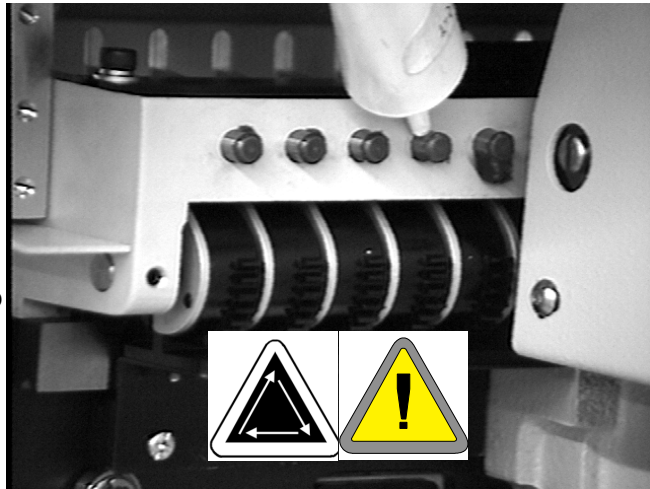



Figure 4-21

2. When **take-up lever cam and follower** displays, press . This causes the needle case to move to needle 1 for proper lubrication. Use a cotton swab and a SMALL AMOUNT OF GREASE to lubricate the take-up lever cam and follower.

Refer to Figures 4-22a and 4-22b to lubricate the take-up lever cam and follower. Use a flashlight if necessary. It is also a good idea to loosen the two screws that are shown in figure 4-22a and pull down the black bracket. This will give you better access to grease the cam and cam follower.

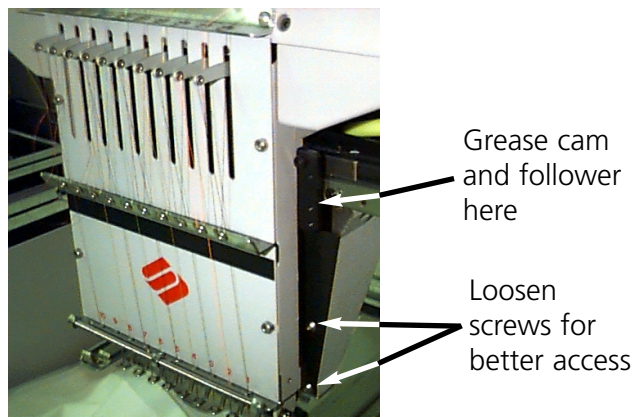


Figure 4-22a

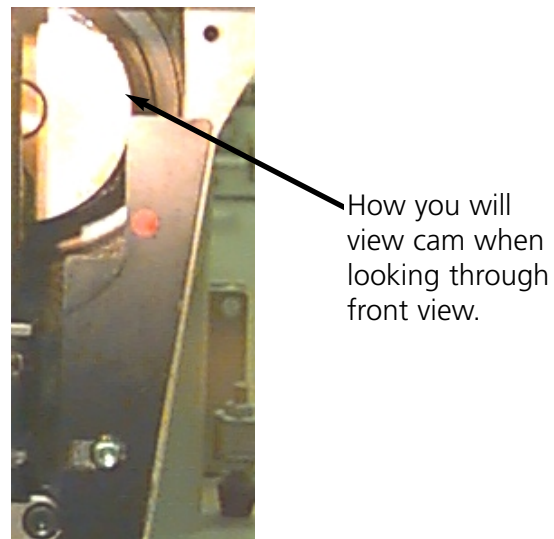


Figure 4-22b

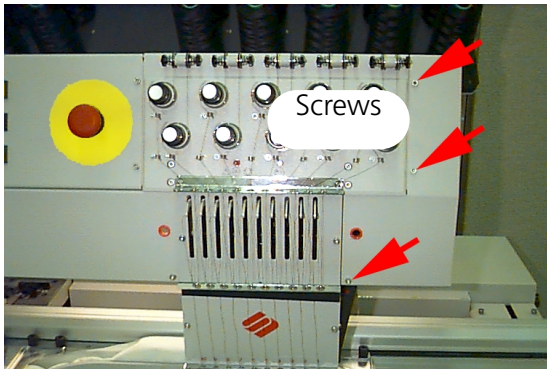



Figure 4-23



Figure 4-24

For an EMT 10/4 or 10/4T, you must remove the end cover to access the cam on head #1. To do this, remove the 3 screws on the front (see Figure 4-23) and loosen the 2 screws along the top (see Figure 4-24). You must lubricate the cam on all 4 heads. Use a flashlight if necessary. Replace the end cover when finished.

Press  when done.

- If you are using a Wide-Angle Cap Frame, the message **Wide-Angle Driver Shaft** will appear; press . Remove the wide-angle driver from the peripheral. Wipe the lint off the driver shaft (see Figure 4-25).

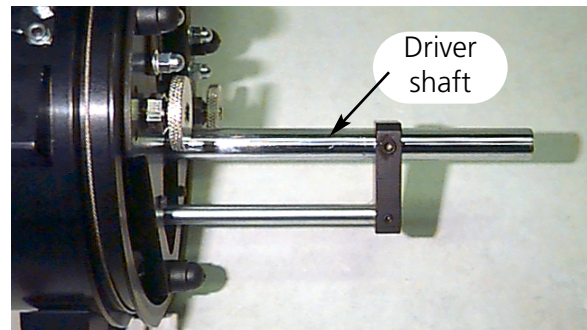


Figure 4-25

Loosen the 2 screws holding the rear support bracket using the 2mm hex wrench (see Figure 4-26).

Remove the rear support bracket.

Pull the driver shaft and driver shaft guide out the front of the driver until the bearings are exposed (see Figure 4-27).

Place 10 drops of oil on the bearings.

Push the driver shaft and driver shaft guide up through the bearing housing.

Attach the rear support bracket and tighten the 2 screws.

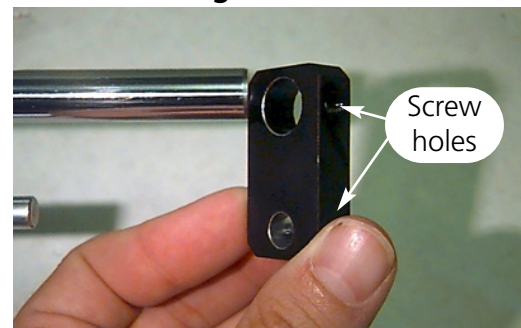


Figure 4-26

Press  when done.

You must perform all operations to clear the message.

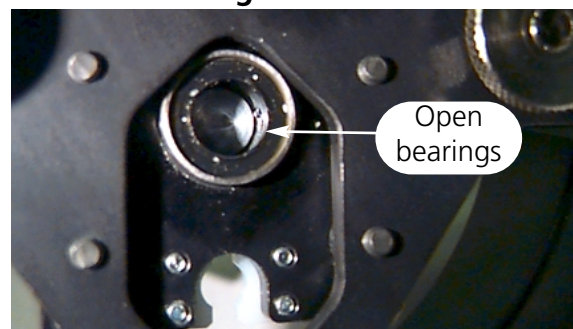


Figure 4-27

## Replacement Parts

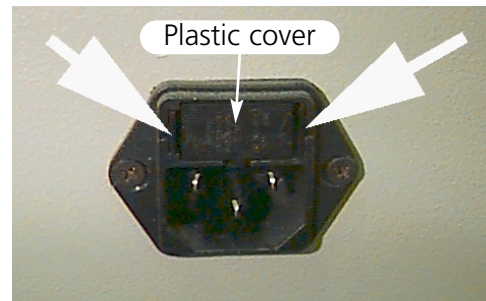
### Fuses

There are two operator-replaceable fuses. If a fuse must be replaced, use this chart for appropriate fuse ratings. Do not use a fuse with any rating other than what is listed here:

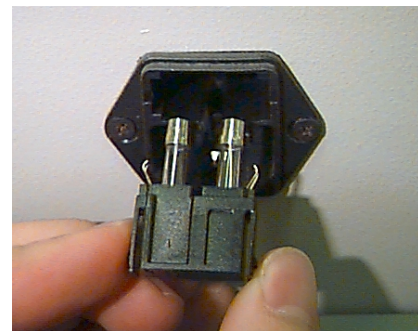
PERIPHERAL	115V RATING (Melco part number)	230V RATING (Melco part number)
EMT 10T F1	5 A (010162-05)	5 A (010162-05)
EMT 10/4	10 A (010162-10)	5 A (010162-05)
EMT 10/4T	10 A (010162-10)	5 A (010162-05)

To replace a fuse, follow these steps:

1. Turn off the power and disconnect the power cord.
2. Directly above where the power cord plugs in is a small plastic cover (see Figure 4-28). Use your fingernails to unclip each side of this cover in the locations shown in Figure 4-28.
3. When the cover is unclipped, pull on the cover to remove the fuse holder (see Figure 4-29).
4. Change the fuses, then replace the fuse holder.
5. Reconnect the power cord and turn on the power.



**Figure 4-28**



**Figure 4-29**

### Tool Kit

The tool kit contains the following items and is included in the operator's kit:

12-piece standard ball hex set	Right angle screwdriver	1/16" ball allen wrench
Phillips #2 screwdriver	Short straight screwdriver	9/64" ball allen wrench
Straight small screwdriver	Tool handle	5/23 ball allen wrench
Phillips offset screwdriver	Tool extension	6-piece metric ball hex set

## Spare Parts

### EMT 10T F1

To help reduce down-time, Melco suggests keeping certain spare parts on hand for easy replacement and maintenance. Melco provides a Spare Parts kit (p/n 10905-01); it contains the following items:

p/n 10905-01	
PART NUMBER	DESCRIPTION
010369-01	CABLE, ETHERNET, NTRWK, INTFC
009448-05	PCB, KYBD, DISPLAY, EMT, ASSY
12754-04	CPU/TI, EMT, ASSY
009000-01	HOOK, ROTARY, SM BOBBIN
004267-01	CASE, BOBBIN
12204-01	PRESSER FOOT, ASSY
10186	KNIFE, MOVABLE, PHS II
009411-02	PCB, CLR CHNG, EMT, ASSY
010107-01	UTC, ASSY
344924-01	STRAP, WRIST, STATIC
10187-01	KNIFE, ADJUSTABLE
10184-01	PRESSER UNDER THREAD, PHS II
008471-01	VELCRO, GRABBER, FLARED
007505-01	SHIM, NDL, CS
110138-01	LIST, HARDWARE, SPARE
001532-01	BAR, NDL
001840-01	CLAMP, STOP, NDL BAR
003586-01	BLADE, GRABBER
001528-01	CLAMP, STOP, NDL BAR
004643-01	SCREW, NDL PLATE
341992-06	SCREW, FIXING ROTARY HOOK

**EMT 10/4 or 10/4T**

To help reduce down-time, Melco suggests keeping certain spare parts on hand for easy replacement and maintenance. Melco provides 4 Spare Parts kits for the EMT 10/4 and 10/4T:

- p/n 010901-01 contains mechanical items for the EMT 10/4
- p/n 010898-01 contains electrical and mechanical items for the EMT 10/4
- p/n 010900-01 contains mechanical items for the EMT 10/4T
- p/n 010899-01 contains electrical and mechanical items for the EMT 10/4T

p/n 010901-01	
PART NUMBER	DESCRIPTION
010689-01	CABLE, ETHERNET, NTRWK, INTFC, 50
010107-01	UTC, ASSY
001532-01	BAR, NDL
007924-01	FOOT, PRESSER, ASSY
004267-01	CASE, BOBBIN, STYLE L, NO SPRING
009000-01	HOOK, ROTARY, SM BOBBIN
10246	PLATE, NDL, POCKETED
001840-01	CLAMP, STOP, NDL BAR
003586-01	BLADE, GRABBER
008471-01	VELCRO, GRABBER, FLARRED
001528-01	CLAMP, NDL, ASSY
001828-01	SCREW, SET, NDL CLAMP
10187-01	KNIFE, ADJUSTABLE
10184-01	PRESSER, UNDER THREAD, PHS II
10186	KNIFE, MOVABLE, PHS II
007505-01	SHIM, NDL CS
007453-01	KIT, HARDWARE, SPARE, 4 HD
004803-01	ASSY, PKNG, SPARE PARTS KIT
010902-01	KIT, FUSE, EMT 10/4(T)

p/n 010898-01	
PART NUMBER	DESCRIPTION
009578-05	PCB, LV DRIVER, ASSY, EMT 10/4
010689-01	CABLE, ETHERNET, NTRWK, INTFC, 50
010280-03	PCB, Y-HOME, ASSY, EMT10/4
12754-04	ASSY, CPU/TI, EMT, W/PROG, CHIPS INSTALLED
344924-01	STRAP, WRIST, STATIC
010107-01	UTC, ASSY
009407-06	PCB, INTFC, ASSY EMT 10
009411-02	PCB, CLR CHNG, EMT, ASSY
001532-01	BAR, NDL
007924-01	FOOT, PRESSER, ASSY
004267-01	CASE, BOBBIN, STYLE L, NO SPRING
009000-01	HOOK, ROTARY, SM BOBBIN
10246	PLATE, NDL, POCKETED
001840-01	CLAMP, STOP, NDL BAR
001528-01	CLAMP, NDL, ASSY
001828-01	SCREW, SET, NDL CLAMP
010027-01	PCB, ESTOP, ASSY, EMT 10/4
10871-01	PCB, KYBD W/ KEYCAPS, DISPLAY, EMT, ASSY
007505-01	SHIM, NDL CS
110231-01	LIST, HARDWARE, SPARE, 4 HD
004803-01	ASSY, PKNG, SPARE PARTS KIT
010902-01	KIT, FUSE, EMT 10/4(T)

p/n 010900-01	
PART NUMBER	DESCRIPTION
010689-01	CABLE, ETHERNET, NTRK, INTFC, 50
010107-01	UTC ASSY
001532-01	BAR, NDL
007924-01	FOOT, PRESSER, ASSY
004267-01	CASE, BOBBIN, STYLE L, NO SPRING
009000-01	HOOK, ROTARY, SM BOBBIN
10246	PLATE, NDL, POCKETED
001840-01	CLAMP, STOP, NDL BAR
001528-01	CLAMP, NDL, ASSY
001828-01	SCREW, SET, NDL CLAMP
007505-01	SHIM, NDL CS
007453-01	KIT, HARDWARE, SPARE, 4 HD
004803-01	ASSY, PKNG, SPARE PARTS KIT
010902-01	KIT, FUSE, EMT 10/4(T)



p/n 010899-01	
PART NUMBER	DESCRIPTION
009578-01	PCB, LV DRIVER, ASSY, EMT 10/4
010689-01	CABLE, ETHERNET, NTRK, INTFC, 50
010280-03	PCB, Y-HOME, ASSY, EMT 10/4
12754-04	ASSY, CPY/TI, EMT, W/PROG, CHIPS INSTALLED
344924-01	STRAP, WRIST, STATIC
010107-01	UTC, ASSY
009407-06	PCB, INTFC, ASSY EMT 10
009411-02	PCB, CLR CHNG, EMT, ASSY
001532-01	BAR, NDL
007924-01	FOOT, PRESSER, ASSY
004267-01	CASE, BOBBIN, STYLE L, NO SPRING
009000-01	HOOK, ROTARY, SM BOBBIN
10246	PLATE, NDL, POCKETED
001840-01	CLAMP, STOP, NDL BAR
003586-01	BLADE, GRABBER
007545-01	VELCRO, WIPER, PILE
001528-01	CLAMP, NDL, ASSY
001828-01	SCREW, SET, NDL, CLAMP
10187-01	KNIFE, ADJUSTABLE
10184-01	PRESSER, UNDER THREAD, PHS II
10186	KNIFE, MOVABLE, PHS II
10871-01	PCB, KYBD W/ KEYCAPS, DISPLAY, EMT, ASSY
007505-01	SHIM, NDL CS
110231-01	LIST, HARDWARE, SPARE, 4 HD
004803-01	ASSY, PKNG, SPARE PARTS KIT
010902-01	KIT, FUSE, EMT 10/4(T)



## 5. Troubleshooting Guide

### Thread breakage

PROBLEM	POSSIBLE CAUSES	SOLUTIONS
Design	Stitches are too short and/or too dense	Check the design for short and/or dense stitches, and edit the design to remove them
Needles	Incorrect needle for thread size being used	Replace with a compatible needle
	Needle is bent, damaged, or dull	Replace needle
	Needle position is incorrect	Install the needle correctly (see needle installation)
	Needle scarf and/or needle eye is burred	Replace needle
Thread	Incorrect thread size for the needle being used	Replace with a compatible needle
	Poor quality thread	Replace with a high quality thread or spray silicone on thread cone
	S-twist (right twist) thread being used	Replace with a Z-twist (left twist) thread
	Improper threading	Thread correctly (refer to threading section)
Upper/bobbin tension	Upper/bobbin tension too tight	Loosen upper/bobbin tension
	Ratio of upper thread to bobbin thread incorrect	Adjust upper and/or bobbin tension (see tension section)
	Incorrect check spring tension/stroke	Adjust/replace check spring (refer to the technical manual)
Fabric and hoops	Fabric is hooped loosely	Tighten fabric in the hoop (see hooping section)
	Inadequate backing allows fabric to pull into needle plate hole	Increase number of backing pieces
Rotary hook	Hook timing is incorrect	Adjust hook timing (refer to the technical manual)
	Rotary hook does not rotate smoothly	Clean, oil, or replace
	Gap between the UTC retaining tab and the rotary hook is too narrow	Widen the gap (refer to the technical manual)
Bobbin	Bobbin is damaged	Replace bobbin
	Bobbin thread feeds poorly	Repair or replace bobbin
Thread path	Scratches or burrs on thread path	Remove scratches with emery cloth
Needle depth	Needle depth is incorrect	Adjust needle depth (refer to the technical manual)

## Skipped stitches

PROBLEM	POSSIBLE CAUSES	SOLUTIONS
Needles	Needle is bent or damaged	Replace needle
	Incorrect needle for the thread size being used	Replace with a compatible needle
	Needle is installed incorrectly	Install needle correctly (see needle replacement section)
Needle depth	Needle bar lowest dead point is incorrect	Adjust needle depth (refer to the technical manual)
Rotary hook	Hook timing is incorrect	Adjust gap (refer to the technical manual)
	Hook point is dull	Replace hook
Upper/bobbin tension	Bobbin thread does not feed out smoothly	Replace the bobbin and/or bobbin case
	Upper thread does not feed out smoothly	Adjust the upper tensions
Presser foot	A weak or broken presser foot prevents the needle from coming out of the fabric smoothly	Replace or strengthen the spring (refer to the technical manual)
Thread	Thread twist is too tight	Use the appropriate thread or consult the service department for suggestions
	Thread is too elastic to form an adequate loop	
Check spring	The check spring stroke is too high	Adjust the check spring stroke (refer to the technical manual)
	The check spring tension is too high	Decrease the tension

## Needle breaks

POSSIBLE CAUSES	SOLUTION
Needle is bent	Replace needle
Needle installation is incorrect	Install correctly (see needle replacement section)
Needle strikes the rotary hook	Adjust hook timing refer to the technical manual)
Poor needle quality	Replace needle
Dull needle tip	Replace needle
Needle is too small for the fabric	Replace with compatible needle
Needle strikes the needle plate	Adjust position of the needle case (refer to the technical manual)
Needle strikes the UTC	Reposition the UTC (refer to the technical manual)

### Loose stitches

POSSIBLE CAUSES	SOLUTIONS
Upper thread tension too low	Adjust the upper thread tensions (see tension section)
Bobbin tension too low	Adjust the bobbin case set screw
Uneven thread size	Replace with quality thread
Upper tension inconsistent	Clean tensioner parts
Rotary hook timing is incorrect	Adjust hook timing (refer to the technical manual)
Inadequate rotary hook lubrication	Lubricate the rotary hook (see the rotary hook lubrication section)
Design density too tight	Decrease density (refer to the EDS manual for design editing)
Gap between UTC retaining tab and hook too wide	Adjust gap (see the UTC adjustments section)

### Other issues

ISSUE	SOLUTIONS
Bird Nesting	Thread may be wrapped around the hook assembly; check hook timing and the UTC retaining finger (refer to the technical manual)
Burrs	Check the needle plate or run the thread test design


## Wide-angle cap frame

POSSIBLE CAUSES	SOLUTIONS
Poor overall embroidery quality	Make sure the cap is hooped properly
	Modify the design
	Check that the tensioner is not installed too tightly
	Check the driver bar cable tension
	Check the spindle adjustment
	Check that the driver was properly adjusted on the peripheral
Puckering	Modify the design
	Check that the tensioner is not installed too tightly
Loss of registration	Adjust cap supports
	Modify the design
	Check that the tensioner is not installed too tightly
	Check the driver bar cable tension
	Check the spindle adjustment
	Check that the driver was properly adjusted on the peripheral
Cap frame is loose on the driver	Adjust the spindles
Cap frame driver doesn't fit on the peripheral properly	Make sure you are using flat needle plates (and NOT raised needle plates)

## 6. Error Messages

---

When the peripheral encounters a problem or needs to give you a status update, a message is displayed on the LCD and the machine beeps.

There may be an error in procedure. For example, an error message is displayed if you press the  key before a design is loaded into the Run buffer. You would respond by loading a design.

It may be a mechanical problem. For example, an error message is displayed if the Y beam reaches its limit before the design finished sewing. You might need to use a larger hoop.


You may have a sewing problem. For example, an error message is displayed when there is a thread break. You would rethread the machine and continue.

The following pages of this section contain an alphabetized list of the error messages. If your machine ever displays an error message that is not listed here, or if you do not know how to respond to a message that is listed here, contact your Melco service representative for assistance.

### Application Run

Means that the peripheral did not download properly. The machine must be turned OFF, then turned ON again. If this does not work, try reconfiguring your peripheral. If this still does not work, try reinstalling the software. Call your Melco service representative if this message occurs often.

### Bad Design Name

The machine could not find the design name when  was pressed. If AutoDelete is ON at the computer, the design is automatically deleted when it finishes sewing. If AutoDelete is OFF, the design was manually deleted from the Design Menu. Reload the design and continue.

### Bad Head Timing Function

Command in the Head Timing Menu was not understood by the Z axis controller. Wait a few seconds and try again. If it still fails, call your Melco Service Representative for assistance.

### Bad Instruction

The CPU received an illegal instruction, resulting in a fatal error. Call your Melco service representative for help.

### Bad Keyboard Code

The machine was unable to read input from the keyboard. Turn the machine OFF and back ON, then do a Power Fail Recovery if necessary. If that does not fix the problem, reconfigure the machine. When you reconfigure, all parameters will be reset to default values, and your design must be started from the beginning. If that fails, call your service representative for help.

### Bad Power Fail Recovery Pointer

While a design is sewn on the machine, a pointer is saved to mark where the last stitch was made to be used in the event of a Power Fail Recovery. If you encounter this message during a Power Fail Recovery, it means the pointer was not properly saved. If you get this message, you will not be able to do a Power Fail Recovery. You may try another method to recover the design, however, such as:

1. Frame through the design to the stopping point; or, if you know the approximate stitch or color change number, you can use the Goto Stitch or Goto Color function.

2. Press  .

If that doesn't work, turn the power OFF and then back ON; make sure the computer is on and you are in EDS III or EDS IV software.

### Check Bobbin

See Thread Break.

### Color Change Axis Current Limit

This message means that the drive circuit of the Color Change axis motor has detected excess power. This is caused by a jammed Color Change axis motor, or a malfunction of the motor or electronics. Turn the machine OFF, then back ON to recover. If this error occurs more than once during a design, call your representative for assistance.

### Color Change Move Timeout

Means the machine did not complete a color change within 5 seconds. This is usually caused by a mechanical bind in the color change assembly which can be corrected by locating and freeing the bind. If there is no bind, use the following instructions to check for an electrical or motor failure:

1. Go to the Idle menu.

2. Press the   keys or the   keys to move the needle case.

3. If the error message clears, press the  key and continue sewing.

If the problem is still not corrected, call your Melco service representative for help.



### **Color Change Pause**

The embroidery peripheral will stop for all color changes when the character P is read in the color sequence. The embroidery peripheral will stop one time when the character O is encountered in the color sequence.

### **Color List Full**

You cannot increase the color sequence to a value greater than 99.

### **Design Delete Failed**

The machine was unable to delete the design due to the same design currently running or another design is being downloaded. Wait 20 seconds and try again. This may also be caused by the design being queued in the Run Menu. If this is the case, perform a **Clear Design** from the Reset menu, then delete the design.

### **Design Job Buffer Full**

Means that no more information may be stored in the peripheral's job queue. This will be displayed in the Run Menu.

### **Design Not Found**

This message displays during a Power Fail Recovery if the machine cannot find the last design that was sewing in the design buffer. Resend the last design from the disk drive and try the Power Fail Recovery again.

### **Disk Directory Error**

Tried to perform a **Directory** command on a floppy disk; either the disk is bad, it is the wrong format, or it is not installed. If you encounter this message during a Power Fail Recovery, make sure the design is on the disk and try again.

### **Disk Load Error**

An error occurred while trying to load a design from a floppy disk. Try loading the design again. If the problem remains, you may have a bad disk or drive.

### DSP Command Error

The motor controller received an invalid command sequence; this results in a fatal error and the CPU halts. Call your Melco service representative for help.

### Duplicate Design

Tried to load a design from a floppy disk, but the same design is already loaded in the machine.

### E-stop Engaged

The Emergency Stop Button is in. Pull or twist slightly to reset.

### Found End of Design

An End Of Design dataset was encountered. This message will occur during a Power Fail Recovery. If this message occurs, you must try another method to recover your design (see **Bad Power Fail Recovery Pointer**).

### Function Not Allowed

The function you are trying to perform is not allowed currently (e.g., Performing a **Hoop Center** command while in the middle of a design is not allowed).

### Grabber Axis Current Limit

This message means that the drive circuit of the Grabber axis motor has detected excess power. This is caused by a jammed Grabber axis motor, or a malfunction of the motor or electronics. Turn the machine OFF, then back ON to recover. If this error occurs more than once during a design, call your representative for assistance.

### Grabber Not Home

Means the thread grabber is not fully retracted to its home position. The grabber may be caught, perhaps on the thread or the Velcro strip. Free the grabber and retract it manually. Press the



key and resume sewing.

### Hoop Limit

If the X or Y motion is not within the sewing field limits when the machine is running, the peripheral will stop and give this error. If performing Frame Forward or Frame Back functions, this error message will be displayed when you reach the limits of rack movement. If not in the Frame Menu, then go to the **Service/Maintenance** Menu and check Hoop Limits in the Configuration Menu. You may be using a hoop size that is too small for the design, or the design start point is not positioned correctly. Try selecting a larger hoop size in the Options menu, or moving the design start point so the whole design fits into the hoop, then start over.

### **Illegal Color Sequence**

In the Color Menu you must have at least one valid thread number in the Color Change Sequence. Valid numbers are 1 to 10 and zero. You cannot exit from the Color Menu without correcting the sequence.

### **Loading Design Try Again**

Means that the design has not completed reloading during a Power Fail Recovery. Wait a few seconds and try again.

### **Machine Running**

You have tried to activate a menu that is not permitted while the machine is sewing. Stop the machine and try again.

### **Missed Headup**

The Z axis controller missed a Head Up signal. The machine waits for another 150 degrees of rotation; and if the signal still hasn't been seen, stops sewing. This error halts the CPU; you must turn the power OFF, then ON, then perform a Power Fail Recovery. If this happens frequently call your Melco service representative for help.

### **Motor Command Buffer Full**

The motor command buffer is full. You may have created more Move commands or Head Timing commands than the buffer can hold. To clear the MC buffer, turn the power OFF, then back ON. If cycling the power does not clear the screen message, there may be an error in the CPU. Reconfigure your peripheral. If this still does not clear the message, call your Melco service representative for assistance.

### **No Designs Found**

This means you are trying to enter the Design menu and there are no designs loaded in memory. Either no designs have been sent from the computer or they have been automatically or manually deleted. The AutoDelete option may be ON at the computer.

### **No Design Qued**

You have attempted to do a Power Fail Recovery, a Goto Stitch, or a Goto Color, but there is no design in the run buffer. You must queue a design and try again.





### **No Free Memory**

Tried to load a design from a floppy disk, but the design memory is full. Delete a design from memory and try again (make sure the design you delete will free enough space for the new design).

### Not At Headup

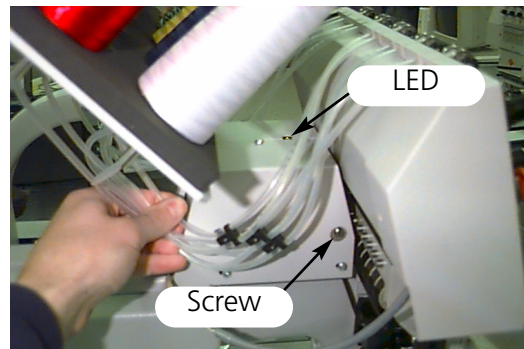
Means you are trying to execute an X or Y move function or color change function when the sewing head is not at Head Up. Cycle to the Head Up position with the Function Menu command GO TO HEADUP.

### Off Color Index

Means the machine tried to do a color change, or you tried to use a Head Timing function while the color change cam was off index. Go to the Idle menu and press the   or   keys to move the color change cam on index. If this does not resolve the problem, try manually resetting the cam.

To manually reset the cam, follow these steps:

1. Locate the Color Change Cam reset screw (it is a flat-head screw). On the EMT 10T F1, it is on the left side of the head (as you are facing the machine), behind the needle case. On the EMT 10/4 and 10/4T it is on the right side of head #1 (as you are facing the machine), behind the needle case. Figure 6-1 shows the locations on an EMT 10T F1. The LED and screw are in the same locations behind head #1 on an EMT 10/4 or 10/4T.



**Figure 6-1**

2. There is an LED on the top of the arm that supports the head. When this light is ON, the head is OFF INDEX. Turn the screw until the light goes OFF.
3. Before you can perform any other functions, you must perform a GOTO HEADUP.

If the problem still exists, call your Melco representative.

### Outside of Hoop

Trying to do a Trim Immediate when the needle is outside of the selected hoop limits.

### Power Fail Recover Job Error

Trying to do a Power Fail Recovery when a design was not started.


### Reload <design name>

An error was found when the computer was loading a design while running in Auto Send. Delete the design and reload it from the computer. Frequent occurrences indicate a system memory problem, or a bad link in the network.

### Run Job Error

Means that no design was selected before pressing the  key in the Run Menu to begin sewing.


### Thread Break

The thread broke, and the machine stopped, then backed up 5 stitches. Make sure the thread path through the tensioner spring and take-up lever is clear, there is bobbin thread, and the needle is installed correctly. Rethread the needle and press the  key. Verify that the check spring is being pulled away from the thread break post.

### Trim Inactive

This means you tried to perform a Trim Immediate while the trim function is disabled. Go to the Configuration Menu in the **Service/Maintenance Menu** and Enable the trim function, then proceed.

### Trimmer Not Home

This message is displayed when  is pressed to begin sewing or a Head Timing Function is performed, but finds the cutting blade is not in its home position. Move the trimmer to the home position manually, then continue sewing. If this does not fix the problem, call your Melco representative.

### X Axis Current Limit

This message means that the drive circuit of the X axis motor has detected excess power. This is caused by a jammed X axis motor or beam or a malfunction of the X axis motor or electronics. Turn the machine OFF, then back ON to recover. If this error occurs more than once during a design, call your representative for assistance.

### X Axis Move Timeout

See Y Axis Move Timeout.

### X Axis Not Done

See Y Axis Not Done.

### X Axis Tracking Error

See Y Axis Tracking Error.

### **X/Y Home is not Set**

Means you tried to do a Move or Trim immediate function without the HOME POSITION being set. Set Home and continue.

### **Y Axis Current Limit**

This message means that the drive circuit of the Y axis motor has detected excess power. This is caused by a jammed Y axis motor or beam, or a malfunction of the Y axis motor or electronics. Turn the machine OFF, then back ON to recover. If this error occurs more than once during a design, call your representative for assistance.


### **Y Axis Move Timeout**

This error message means the Y rack did not complete its commanded move in the allowed time. Repeated occurrences of this message may indicate a mechanical bind in the racks or an electrical problem. To recover from this error exit the Move Function Menu, manually jog the Y rack using the arrow keys, then try the move again. Also, this error can happen while setting home, performing needle ups, or any programmed motion of X and Y while not actually sewing.

### **Y Axis Not Done**

This means the needle is trying to enter the cloth before the X or Y motion is complete. Try to continue sewing; if error returns, call your Melco service representative.

### **Y Axis Tracking Error**

This error message means the Y axis motor is not tracking (or moving) as commanded by the Y axis controller software. This error can occur during sewing, trims, tracing, framing and during moves in the Move Menu. Repeated occurrences of this message may indicate a mechanical bind in the racks or an electrical problem (check for mechanical binds). The machine will stop sewing when this problem occurs. To recover from this error when sewing try to Frame Back a few stitches then press the  key to continue sewing. If this doesn't work turn the machine power OFF then back ON and try a Power Fail Rescue. If this error occurs during tracing, framing or moving functions try the function again.

### **Z Axis Current Limit**


This message means that the drive circuit of the Z axis motor has detected excess power. This is caused by a jammed Z axis motor or a malfunction of the motor or electronics. Turn the machine OFF, then back ON to recover. If this error occurs more than once during a design, call your representative for assistance.

### **Z Axis Timeout Error**

This error message means that the Z axis was commanded to move, but did not complete the move in the allowed time. The message can occur during normal sewing or most functions in the Head Timing menu. To recover, execute the Go To Headup option in the Function menu.

Repeated occurrences of this message may indicate a mechanical bind in the sewing head. It may be, for example, thread gathered in the hook area, remnants of a broken needle, part of a garment, a tangle of thread, or insufficient lubrication. Locate and correct the problem. If you cannot locate the problem or if this message continues to occur often, call your Melco service representative .

### **Z Axis Tracking Error**

This means the Z axis motor is not tracking as commanded by the Z axis controller software. Execute the Go to Headup option in the Function Menu. Exit the Function Menu and press the  key to continue sewing. If the message does not clear, call your Melco representative for assistance.

### **Zero Dimension**

This message appears when you are creating a custom hoop, but the X or Y dimensions are set to zero. Change the X and Y dimensions to a number greater than zero to clear the message.





## 7. Glossary of Embroidery Terms

---

### A

#### **ACTIVE WINDOW**

The window that you are currently using. Also called the current window.

#### **ALPHABETS**

Lettering styles that are ready to use for embroidery. Alphabets can also be designs that are brought to the screen using letters of the alphabet. An example of this would be Sports Symbols.

#### **APPLICATION WINDOW**

The first window to appear when EDS III / IV is opened; screen says Melco in large letters across the middle of the screen. The Application Window has three menu bar items; File, Peripheral, and Help.

#### **APPLIQUE**

The art of using fabric shapes with satin stitch outlines to enhance a design or to reduce the stitch count.

#### **ARTWORK**

A design or cartoon used to digitize.

#### **AUTO DELETE**

An option that automatically deletes designs from the sewing peripheral after the design has sewn once. Machine will display Bad Design Name when the design finishes.

#### **AUTO RUN**

An option that automatically sends a design to the beginning of the job queue, allowing you to sew without making any selections from the peripheral menus.

#### **AUTO TRIM**

An option that automatically inserts a trim command between each letter of any alphabet (including scripts) used in a design.

#### **ARC ANGLE**

The center of lettering sewn on a circle. This position is given in degrees, 0° at the top of the circle, 180° at the bottom.

#### **ARC FROM CENTER**

When the position of the needle prior to sewing is at the center of the circle. The distance from the center of the circle to the bottom of the lettering is the radius. When traced, the trace includes the entire area.

#### **ARC NORMAL**

When the position of the needle prior to sewing is on the circumference of the circle. When traced, only the areas of the lettering is traced.

**ASD**

The file extension given by EDS III / IV to a design that is sent to the peripheral.

**B****BACKING**

Fabric used for stabilizing that is added to the back of a garment to be embroidered.

**BEAN STITCH**

A form of running stitch where the stitch is made forward, then back to the original needle penetration point, then forward again. Also known as a triple run.

**BIRD NEST**

A tangled mass of thread that gets jammed in the needle plate. Sometimes it is caused by improper tensions or densities.

**BIT PAD**

Another name for a Digitizing Tablet.

**BLOCK**

A designated group of stitches that can be scaled, rotated, repositioned, deleted, cut, copied and pasted.

**BLOCK EDIT**

The term used for changing a defined group of stitches.

**BOBBIN**

The reel or spool that holds the under thread of machine sewing. The under thread itself.

**C****CENTER DESIGN**

Positing the design in the center of the sewing field.

**CHAIN STITCH**

A stitch used to outline and detail a chenille design.

**CHENILLE**

A form of embroidery with a deep pile that uses heavy yarns and has no bobbin thread. Commonly used for high school letter jackets.

**CLICK**

Pressing and releasing a mouse button in one quick motion.

**CLIPBOARD**

A temporary storage area in the computer's memory. Data in the storage area can be copied to another place.

**CND**

The three letter extension given to a Condensed file. See Condensed Format for more information.

**COLUMN FILL**

An option to turn wide column or satin stitches into a series of shorter stitches. Commonly used to make alphabet letters 2.5" or larger more durable.

**COLUMN STITCH**

A stitch formed with one needle penetration on either side of a column. Also referred to as a satin stitch or a steil stitch.

**COLUMN WIDTH**

The width of the actual side-to-side needle penetrations in a column or satin stitch. In EDS III / IV, the width can be increased or decreased in increments of 10% from 90% to -90%.

**COMPLEX FILL**

A method for digitizing fills where the computer automatically determines the various independent segments that are required in making the complete fill of an irregular shape.

**CONDENSED FORMAT**

A coding format that includes only the data for the Mk entries and function commands created during digitizing. This format allows you to scale the design up or down as well as change the density and stitch length of the design.

**COPY**

A command that keeps the design in the current window and also stores it in a temporary memory called the clipboard.

**CURSOR**

An icon used to indicate your position on the computer screen.

**CUT**

An editing function used to take selected stitching out of a design and store it in the clipboard. From there it may be pasted to a different place.

**D****DATASET**

Any single line in the stitch list. An example would be any Mk point.

**DEFAULTS**

Values that are automatically used unless you override them with different values.

**DENSITY**

The space between needle penetrations, measured in points—not the number of stitches per inch.

**DESIGN FILE**

Any design stored on your hard disk or floppy disk. A file name can have up to eight letters, a period, and a three letter extension.

**DIALOG BOX**

A box displayed on your computer screen that prompts you to give information, such as a selection from a list of options, or a file name.

**DIGITIZING**

Converting artwork into a series of commands that can be read by an embroidery machine with the use of a special device.

**DIGITIZING TABLET**

A board used to communicate with a computer or an embroidery machine while creating a design.

**DIGITRAC**

The original Melco computerized digitizing system which uses an exceptionally large surface and its own vertical stand.

**DIRECTORY**

A named group of computer files stored on one of your computer drives. The hard drive of your computer is usually the C directory. Floppy diskettes are inserted into the A or B drive. The CD-ROM drive is usually the D drive.

**DISK**

A computer data storage device which is accessed in the hard drive or one of the floppy drives. The hard drive of your computer is usually the C drive. Floppy diskettes are the A or B drive. The CD-ROM drive is usually the D drive.

**DISKETTE FORMAT**

The manner in which a disk has been prepared to accept information.

**DITHERED COLORS**

A combination of a solid color and a pattern.

**DOUBLE CLICK**

Pressing the mouse button quickly two times.

**DRAG**

Holding down the mouse button while moving the mouse. This is usually done to move an object on the screen or to highlight text.

**DROP-DOWN MENU**

A list of available commands that displays when you click on a menu option. Commands displayed in black are accessible, commands that are displayed in gray or half tone are not.

**E****EDIT**

Changing a design file by adding, deleting or moving Mk points, or by inserting and deleting functions.

**EMBROIDERY POINT**

A unit of measure equal to one tenth of a millimeter or 1/254th of an inch.

**EXP**

The three letter extension given to an Expanded file.

**EXPANDED FORMAT**

A coding format that includes the data for every stitch in the design.

**EXPORT**

Copying a design from the computer to a non-DOS format diskette or paper tape.

**EXTENSIONS**

The last part of a file name after the period. It can be up to three characters long and is used to identify the type of file.

**F****FILE**

A collection of information, named and stored on a disk. Every piece of information on your computer's hard drive is stored in a file.

**FILE NAME**

The unique identifier given to a design that is stored on a computer. The file name can have up to eight characters, a period, and an up to three letters extension.

**FILL STITCH**

A series of running stitches used to cover large areas.

**FORMAT**

Preparing a disk to receive information. All new disks must be formatted, but reformatting a disk destroys any information stored on it. Your computer uses a DOS format, but you can format floppy disks to machine language formats.

**FUNCTION**

An action caused by a command in a design such as Trim, Color Change, Needle Up, etc.

**G****GRAPHICAL ROTATION**

Angling a design in the Layout window using the mouse to click and drag the rotation box around the object.

**GRAPHICAL SCALING**

Making a design larger or smaller in the Layout window using the mouse in a click and drag motion.

**GROUP OBJECTS**

Objects that have been locked together on the screen.

**H****HARD DISK**

A sealed disk in your computer with a read/write head and auxiliary memory. Usually the C drive.

**HOOP**

A device made of wood, metal, or plastic used to hold a garment or fabric taut during the embroidery process.

**HORIZONTAL SPACING**

Additional spacing that may be added between Alphabet letters.

**I****ICON**

A small graphic representation of something larger.

**IMPORT**

Bringing a design file into the EDS III / IV program from a non-DOS formatted diskette or paper tape.

**INSERT**

Adding additional information to an existing design.

**J****JUMP STITCH**

A frame movement without a needle penetration. Its function allows you to make a stitch longer than the maximum stitch length of your machine.

**L****LAYER BY COLOR**

Used to show specific colors of a design on the computer screen. Only works in the Object Edit Window.

**LAYOUT WINDOW**

The screen in which you can digitize designs, open files on the hard disk, import designs from floppy disks, export designs, modify designs, and create lettering.

**LETTER WIDTH**

Modifies the overall width of each letter, NOT the column width. In EDS III / IV changes to letter width can be made in increments of 10% from +30% to -30%.

**LINE CENTER BOTTOM**

When lettering is centered horizontally and above the position of the needle prior to sewing. It will sew above  $Y=0^\circ$  except for lower case letters such as **g, y, p, or q**; used to sew over a straight line on fabric such as a pocket.

**LINE CENTER MIDDLE**

When lettering is centered horizontally and vertically from the position of the needle prior to sewing.

**LINE NORMAL**

When the bottom left of the lettering is the needle position prior to sewing. The sewing will stop at the bottom right and will not return to the original position. It will sew above  $Y=0^\circ$  and to the right of  $X=0^\circ$  used to position design; used to align to the right of a vertical line such as a plaquet.

**LINE SPACING**

Adding space between lines of lettering in the same text box. Line space is determined by adding the letter height to the amount of blank space you want between the lines.

**LIST BOX**

A box, usually with a scroll bar, that appears within a dialog box and displays available options.

**LOAD FILL**

Accessing a fill pattern for inspection or changes.

**LOCK GROUP**

One or more objects that have been joined together.

**LOCK STITCH**

Three or more stitches placed closely together to prevent the embroidered stitches from pulling out. Also know as a tie-off stitch.

**M****MAXIMIZE**

The small button to the right of the Title Bar with the up arrow. Used to enlarge a window to its fullest extent.

**MAXIMUM STITCH LENGTH**

The longest stitch your embroidery machine is capable of sewing before performing a jump stitch. The maximum stitch length for Melco is 127 pts.

**MINIMIZE**

The small button on the right of the Title Bar with the down arrow. Used to reduce a window to an icon.

**MODIFY Mk BUTTON**

An option that changes the position of a Mk point or changes the Mk to a different type of Mk. Double-clicking on a specific point in the stitch list opens the Modify Mk dialog box.

**MOSS STITCH**

The "loopy" part of a chenille design. The height of the loop is controlled by the height of the needle.

**MULTIHEAD**

An embroidery machine with more than one sewing head.

**N****NEEDLE UP**

A command used to move from one part of a design to another without stitching.

**NON-DOS FORMATS**

Any disk format other than DOS that is supported by EDS III / IV, such as: Melco, Tajima, Barudan, ZSK.

**NORMAL STITCH**

A command that resets the stitching to a regular running stitch. It also brings the needle down to the sewing position after a needle-up function is performed.

**O****OBJECT**

Any design from a disk, paper tape, or lettering brought in to the Layout window. Several objects can be in one window at one time.

**OBJECT FILE**

A code format where each object has its own separate set of parameters. Condensed, expanded and lettering designs can all be saved together as an Object File.

**OBJECT ORDER**

A list showing the sewing order of a group of objects.

**OBJECT PARAMETERS**

A dialog box which allows you to change the scale, rotation, orientation, or lock status of an object.



**OFM**

The three letter extension that identifies an Object file.

**ORIENTATION**

The direction that a design will sew. Melco uses an "F" to designate a normal sewing position.

**ORIGIN**

The point at which a design will start. Most designs will have x and y coordinates of 0,0; meaning that the design will start in the center and end in the center.

**P****PAPER TAPE**

An older form of computer information storage in which the information is stored as a series of holes on a reel-to-reel paper tape.

**PARTITION LINE SEQUENCE**

Determines where the needle will penetrate on each line of stitching in a fill stitch. Changing this sequence changes the texture of a fill.

**PERIPHERAL**

Any device that is attached to or run by the computer: Embroidery Machines, Paper Tape Punches, Digitizing Tablets, Printers, or Plotters.

**PERIPHERAL SETUP**

A dialog box that allows you to select Embroidery Peripherals in your network.

**PERIPHERAL STATUS**

A dialog box that displays information about a particular peripheral.

**POINT EDIT WINDOW**

One of the windows that is used to edit designs.

**R****RADIUS**

The distance from the center to the circumference of a circle. The value of the radius controls the amount of curve in an arc.

**REGENERATE**

A command to redraw a design, used to see modifications in the current design.

**RESET STITCH**

See Normal Stitch.

**RETURN TO ORIGIN**

A command used to move the pantograph back to the origin of the design.

**RUBBER BANDING**

A command to view an edited portion of a design without regenerating the entire design.

**RUNNING STITCH**

A line of equally spaced stitches that are used to outline, underlay or add detail to a design.

**S****SATIN STITCH**

A stitch formed with one needle penetration on either side of a column. Also called a column stitch or steil stitch.

**SAVE**

A command to overwrite a previously saved file without prompting you for a new filename.

**SAVE AS**

A command to store a design for the first time, or to store a modified design with a new name to prevent destruction of the original design.

**SAVE FILL**

A command to allow you to define fill information while digitizing.

**SCALING**

The process of changing the size, density or stitch lengths in a design.

**SCROLL BAR**

A bar that appears at the far right or bottom edge of a window or list box whose contents are not fully visible. Clicking on the arrows of the bar moves the viewing portion of the screen.

**SEND DESIGN**

Sends all items on the screen together under one design name. The design can be a condensed, expanded, or object file.

**SHORT STITCHES**

Computer generated stitches that do not go all the way across a column at a curve or angle to prevent an excess of stitches at one point cutting the fabric. Short Stitches defaults to ON, but may cause gaps in smaller letters and should be turned off in letters 0.5" or smaller.

**SLANT ANGLE**

A command that slants lettering in one degree increments up to fifteen degrees, positive or negative.

**SPECIAL STITCH**

A user defined stitch that is digitized and stored temporarily in the computer memory. A Special Stitch is limited to 30 Mks or commands.

**STATUS BAR**

The area at the bottom of the computer screen that displays information about the active window or selected command.

**STITCH**

One needle penetration made by the embroidery machine.

**STITCH COUNT**

The number of stitches in a design.

**STITCH LENGTH**

The length of the running stitches in a design. Measured in points.

**STITCH LIST (condensed)**

Information showing the Mk points and functions that make up a design.

**STITCH LIST (expanded)**

Information showing the actual stitches and functions that make up a design.

**STITCH PROCESSOR**

An EDS III option that changes the size, densities, or stitch lengths of an expanded design.

**STORED SYMBOL**

A portion of a design that is digitized as a separate piece to be used multiple times within the same design. An example of this would be a leaves on a tree. You would digitize one leaf as a stored symbol then use that same leaf and place it on the tree at various different sizes and angles. This eliminates redigitizing the same design.

**T****TIE OFF**

See Lock Stitch.

**TILE**

Allows you to put up to nine windows in the Application Window.

**TOOL SET**

The commands and options on the left side of the window represented by icons.

**TRANSFER DESIGN**

A command that sends Expanded or ASD files to the Peripheral.

**U****UNDERLAY**

Stitches used to stabilize fabric and/or prepare the area for top stitching.

**UTC**

UTC is the Under Thread Control. It is a sensor mounted to the needle plate bracket that recognizes the absence of the bobbin thread. When the machine sews a certain number of stitches without bobbin thread, the UTC causes the machine to stop, back up that number of stitches, and display the error message, CHECK BOBBIN. The UTC also has a retaining tab that holds the inner basket of the rotary hook. The UTC arm must be set close enough to allow the thread to move it as stitches are made. Incorrect alignment of the UTC generates repeated **Check Bobbin** error messages.

**V****VERTICAL SPACING**

A command that stair steps your lettering up (positive value), or down (negative value).

**W****WINDOW**

A rectangular area on your screen in which you view and work on designs.

**Z****ZOOM**

A command that enlarges or reduces a portion of a design in the current Layout window, allowing you to edit with more precision. This command does not affect the sewing size of the design. To view the design as the size it will be sewn, click View→Actual Size.

+5 Volt Current: 2-19

1 degree back: 2-13

1 degree forward: 2-13

10 degrees back: 2-13

10 degrees forward: 2-13

2100 Hr Lubrication Menu: 2-14

2100hr maintenance due: 4-10

4 Hr Lubrication Menu: 2-14

40 Hr Lubrication Menu: 2-14

40hr maintenance due: 4-5

480 Hr Lubrication Menu: 2-14

480hr maintenance due: 4-9

8 Hr Lubrication Menu: 2-14

80 Hr Lubrication Menu: 2-14

80hr maintenance due: 4-5

8hr maintenance due: 4-4

## **A**

Accessories: 3-1

Accumulate needle ups:: 2-15

Application Run: 6-1

## **B**

Bad Design Name: 6-1

Bad Head Timing Function: 6-1

Bad Instruction: 6-1

Bad Keyboard Code: 6-2

Bad Power Fail Recovery Pointer: 6-2

BIOS rev level: 2-19

Bobbin Control Test: 2-19

Bobbin detect count:: 2-15

Bobbin detect:: 2-15

Bobbin Winder: 3-21

Bottom tensions: 2-6

## **C**

Cap designs: 3-16

Cart Assembly: 1-6

Center design:: 2-12

Center hoop: 2-23

Check Bobbin: 6-2

Cleaning: 4-2

Clear design: 2-12

Color Change Axis Current Limit: 6-2

Color Change Move Timeout: 6-2

Color Change Pause: 6-3

Color List Full: 6-3

Color Menu: 2-8, 2-26

Configuration Menu: 2-15

Configuring the peripheral: 1-13

Connecting cables: 1-10

## **D**

Define custom hoop: 2-18

Design Delete Failed: 6-3  
Design filter stitch length:: 2-16  
Design filter:: 2-16  
Design Job Buffer Full: 6-3  
Design Menu: 2-8  
Design Not Found: 6-3  
Diagnostic tests: 1-13  
Diagnostics Menu: 2-19  
Directory Menu: 2-21  
Disk design format: 2-12  
Disk Directory Error: 6-3  
Disk Directory Menu: 2-8  
Disk Drive: 2-20  
Disk Load Error: 6-3  
DSP Command Error: 6-4  
Duplicate Design: 6-4

## **E**

Embroider: 2-27  
Embroidery Speed: 2-27  
EMT 10/4 and 10/4T Specifications: v  
EMT 10T Specifications: iv  
Error Messages: 6-1  
E-stop Engaged: 6-4  
Ethernet network: 1-12

## **F**

First powerup: 1-13  
Flat hoops: 2-25  
Format: 2-21  
Format Selection: 2-21  
Found End of Design: 6-4  
FPGA rev level: 2-19  
Frame Menu: 2-12  
Function Menu: 2-9  
Function Not Allowed: 6-4  
Fuses: 4-12

## **G**

Go to color change?: 2-10  
Go to headup: 2-13  
Go to headup?: 2-11  
Go to hoop center?: 2-9  
Go to stitch?: 2-10  
Grabber Axis Current Limit: 6-4  
Grabber Not Home: 6-4  
Grabber Test: 2-19

## **H**

Hard reset: 2-12  
Hazards of operation: 2-2  
Head Timing Menu: 2-13  
Hook timing: 2-13  
Hoop Limit: 6-4

Hoop limits:: 2-16

Hooping: 2-22

## **I**

Idle Display: 2-27

Illegal Color Sequence: 6-5

Inching count:: 2-17

Installation: 1-1

Installing a Needle: 4-1

Installing the feet: 1-7

Installing the tabletop: 1-8

## **K**

Keypad: 2-1, 2-6

## **L**

Lamps: 3-20

Language selection: 1-14

Language selection:: 2-17

Loading a Design: 2-21

Loading Design Try Again: 6-5

Lock stitch:: 2-15

Lubrication: 4-3

## **M**

Machine Running: 6-5

Main Operator Menu: 2-8

Main tensioners: 2-6

Maintenance: 4-1

Max Jump Stitch Speed: 2-17

Menu: 2-8

Missed Headup: 6-5

Motion Controller rev level: 2-19

Motor Command Buffer Full: 6-5

Move function: 2-17

Move Function Menu: 2-17

Moving: 1-4

## **N**

Needle: 4-1

Needle case: 2-1

Needle depth: 2-13

No Design Qued: 6-5

No Designs Found: 6-5

No Free Memory: 6-5

Not At Headup: 6-6

## **O**

Off Color Index: 6-6

One revolution: 2-13

Operation: 2-1

Operator Kit: 4-13

Options Menu: 2-11

Orientation option:: 2-12

Outside of Hoop: 6-6

**P**

Power Fail Recover Job Error: 6-6

Power Fail rescue?: 2-9

Power requirements: 1-10

Power switch: 2-1

Pretensioners: 2-6

**R**

Raised needle plates: 3-4

Reload <design name>: 6-6

Replacement Parts: 4-12

Reset Menu: 2-12

Return to design origin at EOD (end of design)::  
2-15

Return to last stitching position?: 2-10

Return to origin?: 2-10

RSA Files: 2-20

RSA rev level: 2-19

Run Design Menu: 2-8

Run Job Error: 6-7

Run Menu: 2-26

**S**

Sash Frame: 3-17

Select a design: 2-26

Select hoop: 2-11, 2-23

Select orientation: 2-23

Service/Maintenance Menu: 2-12

Set home: 2-23

Set home?: 2-9

Sew timers: 2-19

Spare Parts: 4-14

Spider Hoops: 3-18

Standard Cap Frames: 3-1

Start rack motion offset:: 2-16

Support brackets: 1-15

Symbols: vi

**T**

Table: 2-1

Tensions: 2-5

Test Mode: 2-18

Thread Break: 6-7

Thread Break Indicator LED: 4-2

Thread Break Switch: 4-1

Thread tree: 2-1

Thread trimmer:: 2-15

Threading: 2-4

Time to oil hook: 4-3

Tool Kit: 4-12

Top dead center: 2-13

Top tensions: 2-6

Trace design outline?: 2-9



Trace the Design: 2-26

Trim immediate?: 2-9

Trim Inactive: 6-7

Trim jump count:: 2-12

Trim on stitch length:: 2-15

Trimmer Not Home: 6-7

Trimmer tail length:: 2-15

Troubleshooting: 5-1

Tubular hoops: 2-24

Turbo mode:: 2-12

## **U**

Unit of measure:: 2-16

Unpacking: 1-1

## **W**

Wide-angle cap frame: 3-6

## **X**

X Axis Current Limit: 6-7

X Axis Move Timeout: 6-7

X Axis Not Done: 6-7

X Axis Tracking Error: 6-7

X/Y Home is not Set: 6-8

X-beam: 2-1

## **Y**

Y Axis Current Limit: 6-8

Y Axis Move Timeout: 6-8

Y Axis Not Done: 6-8

Y Axis Tracking Error: 6-8

## **Z**

Z Axis Current Limit: 6-8

Z Axis Timeout Error: 6-9

Z Axis Tracking Error: 6-9

Z position: 2-13

Zero Dimension: 6-9



---

# Quick Reference Guide

For The  
EMT 10T F1,  
10/4, and  
10/4T

---

15338 Revision D

  
**Melco**  
Embroidery Systems  
A Saurer Group Company

# EMT 10T F1, 10/4, and 10/4T QUICK REFERENCE

## Select a Hoop Size

1. Press until the display reads: OPTIONS MENU.
2. Press .
3. Press or to scroll to right the hoop size.
4. Press until the display reads: FUNCTION MENU. Press .
5. Press or until the display reads: GO TO HOOP CENTER.
6. Press .

## Select an Orientation

1. Press until the display reads OPTIONS MENU. Press .
2. Press or until the display reads ORIENTATION.
3. Press or to scroll to the desired orientation. Press .

## Reset Designs

1. Press until the display reads: RESET MENU.
2. Press . The display reads: CLEAR DESIGN.
3. Press . The display reads \*\*RESET\*\*.

## Load a Design (from the Disk Drive)

1. Press to display the Directory Menu.
2. Place the diskette with the design to be loaded in the disk drive, then press .
3. Press or until the desired design name is showing on the display, then press . When the design is loaded, the display will read: DESIGN MENU.

## Run a Design

1. Press until the display reads: DESIGN MENU.
2. Press .
3. Press or to scroll to the design you want, then press .
4. The display reads: COLOR MENU; press .
  - Press or to select the sequence.
  - Press or to select the color.
  - Press or to delete a sequence.
  - Press or to insert a sequence.
5. Press . The display reads: RUN DESIGN.
6. Press . First the display reads: <machine name> READY, then shows the design name.
7. Press until the display reads: FUNCTION MENU.
8. Press .
9. Press or until the display reads: TRACE DESIGN OUTLINE.
10. Press . First the display reads: CALCULATING, then shows the design name.
11. Press . The trace function begins.

Repeat by pressing again.

12. When ready to sew, press , then press .
13. Press to begin embroidering.

## Raise the Needle

1. Press until the display reads: FUNCTION MENU.
2. Press .
3. Press ; the display shows GO TO HEADUP.
4. Press ; the needle comes up.
5. Press to exit the function menu.

## Delete a Design

1. Press until the display reads: DESIGN MENU.
2. Press .
3. Press or to scroll to the right design file.
4. Press or . The display reads: DELETE FILENAME?.
5. Press for YES or for NO.
6. Press .

## Hot Keys

- Press or to toggle between the Main menu and the Service/Maintenance menu.
- Press or to toggle in and out of the Language selection menu.
- Press or to increase sewing speed.
- Press or to decrease sewing speed.
- Press or to move the needle case manually (e.g., for a color change).
- Press and any arrow key to manually jog the rack.

---

# Quick Reference Guide For The EMT Menus and Commands

---

15338 Revision D

# EMT MENU AND COMMAND QUICK REFERENCE

## IDLE MODE

Two displays are available whenever the machine is in Idle Mode:

- ▲ Current stitch, max speed, and needle number
- ▲ Name, current speed, orientation, and needle number

## MAIN OPERATOR MENU

- ▲ Directory Menu
- ▲ Design Menu
- ▲ Color Menu
- ▲ Run Design Menu
- ▲ Function Menu
  - ▢ Go To Hoop Center
  - ▢ Trace Design Outline
  - ▢ Trim Immediate
  - ▢ Set Home
  - ▢ Power Fail Rescue
  - ▢ Return To Origin
  - ▢ Return To Last Stitching Position
  - ▢ Go To Stitch
  - ▢ Go To Color Change
  - ▢ Go To HeadUp
- ▲ Options Menu
  - ▢ Select Hoop
  - ▢ Orientation Option
  - ▢ Trim Jump Count
  - ▢ Turbo Mode
  - ▢ Center Design
  - ▢ Floppy Disk Format
- ▲ Frame Menu
  - ▢ Frame Back
  - ▢ Frame Forward
- ▲ Reset Menu
  - ▢ Clear Design
  - ▢ Hard Reset

## SERVICE/MAINTENANCE MENU

- ▲ Head Timing Menu
- ▲ 4 Hour Lubrication Menu
- ▲ 8 Hour Lubrication Menu
- ▲ 40 Hour Lubrication Menu
- ▲ 80 Hour Lubrication Menu
- ▲ 480 Hour Lubrication Menu
- ▲ 2100 Hour Lubrication Menu
- ▲ Configuration Menu
  - ▢ Thread Trimmer
  - ▢ Trimmer Tail Length
  - ▢ Trim on Stitch Length
  - ▢ Bobbin Detect
  - ▢ Bobbin Detect Count
  - ▢ Lock Stitch
  - ▢ Accumulate Needle Ups
  - ▢ Return to Design Origin at EOD
  - ▢ Start Rack Motion Offset
  - ▢ Unit of Measure
  - ▢ Hoop Limits
  - ▢ Design Filter
  - ▢ Design Filter Stitch Length
  - ▢ Language Selection
  - ▢ Inching Count
  - ▢ Max Jump Stitch Speed
- ▲ Move Function Menu
  - ▢ Move X/Y
- ▲ Define Custom Hoop Menu
- ▲ Test Mode Menu
- ▲ Diagnostics Menu

## Key

- ▲ = View available when machine is in idle state
- ▢ = Top-level menu
- = Sub-menu
- ▢ = Command or function