

Technical manual for the EMC 10/12 multi-head embroidery machine

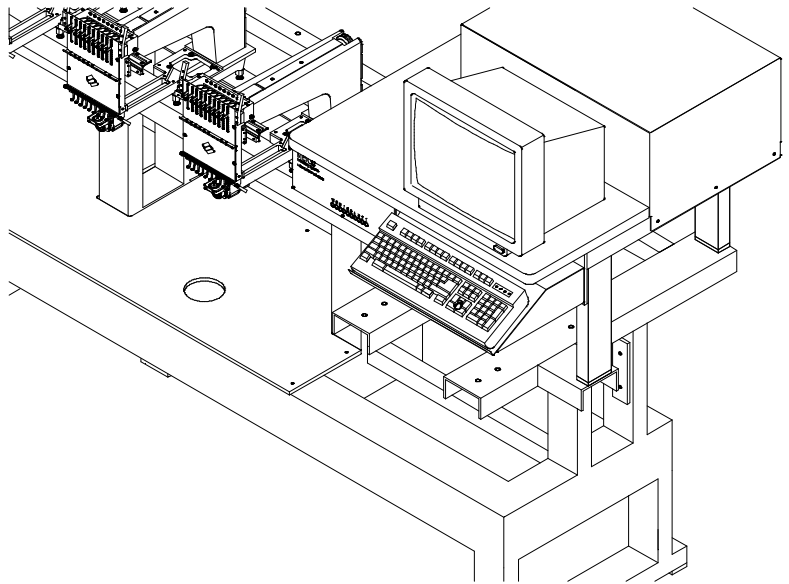

- Twelve Melco Embroidery Heads
- 10 Needles with automatic color change
- Automatic Trimmers
- Caps, Tubular, Sash Frame
- **CE**

Melco 
Embroidery Systems

1575 West 124th Avenue
Denver, Colorado 80234
United States of America
E-mail via the Internet: publications@melco.com

Copyright © Melco Embroidery Systems, 1997.

ALL RIGHTS RESERVED No part of this publication may be reproduced, stored in a retrieval system, or transmitted in any form or by any means (electronic, mechanical, photocopying, recording, or otherwise) without prior written approval of Melco Embroidery Systems. Melco reserves the right to revise this publication and to make changes in it at any time without obligation of Melco to notify any person or organization of such revisions or changes.

All precautions have been taken to avoid errors or misrepresentations of facts, equipment, or products. However, Melco Embroidery Systems does not assume any liability to any party for loss or damage caused by errors or omissions.

First Printing: May, 1997

Table of Contents

1. Introduction

Scope Of Manual	1 - 1
Conventions Used In Manual	1 - 1
Explanation Of Symbols	1 - 1
Glossary Of Terms	1 - 2
Maintenance Philosophy	1 - 2
Static Electricity And Grounding Strap Use	1 - 2
Warranty Considerations	1 - 2
System Overview	1 - 3
Physical/Functional Arrangement	1 - 3

2. Service Adjustments

General	2 - 1
Drive Belt Tensions	2 - 1
The SEEM C.Tronic 87 Type 105 Belt Tension Gauge	2 - 1
Carriage Section	2 - 2
X and Y Drive Belt Tensions	2 - 2
Under Carriage Section	2 - 4
X and Y Motor Belt Tensions	2 - 4
Attach Motor and Belt	2 - 5
Measure Belt Tension	2 - 5
Power Supply Assembly	2 - 6
System Operating Voltage	2 - 6
Motor Voltage	2 - 6
System Logic Voltage	2 - 6
Embroidery Heads	2 - 9
Z Drive Mechanical System	2 - 9
Setting The Shaft Couplings and Thrust Bearings	2 - 9
Synchronizing The Heads	2 - 11
Shaft Drive Gear Mesh	2 - 12
Z Encoder System Introduction	2 - 13
Z Encoder Inspection	2 - 13
Z-Axis Encoder Calibration	2 - 14
Thread Tensioner Check Spring Adjustment	2 - 16
Adjustment Hints	2 - 16
Cross Roller Bearing Centering	2 - 17
Retainer Plate Bearing Adjustment	2 - 19
Alternate Method	2 - 20
Lower Rail Retainer Adjustment	2 - 21
Jump Stitch Solenoid	2 - 22
Plunger Positioning	2 - 22
Bracket Positioning	2 - 23

Color Change Motor Belt Tension	2 - 24
Color Change Link Bar Adjustment (Needle Centering)	2 - 24
Thread Break Brush Adjustment	2 - 26
X and Y Stop/Limit Encoder Adjustments	2 - 27
Center Index	2 - 27
Cap Frame Limits	2 - 28
Flats Limits	2 - 32
Trimmer System	2 - 33
Sequence of Trim Events	2 - 33
Trimmer Setup And Adjustments	2 - 34
Spring Knife	2 - 35
Under Thread Presser	2 - 37
Movable Knife Adjustment	2 - 39
Movable Knife Home Position	2 - 39
Trimmer Cam Position	2 - 41
Select Position	2 - 43
Picker Finger Center Position	2 - 44
Picker Home Position	2 - 45
Picker Height/Depth Position	2 - 45
Grabber Setup And Adjustments	2 - 46
Under Thread Control (UTC) Adjustments	2 - 47
Rotary Hook Retaining Finger Positioning	2 - 48
Sew Test	2 - 50
Preliminary Checks	2 - 50
Perform The Test	2 - 50

3. Mechanical Disassembly

General	3 - 1
EMC 10/12 User Station	3 - 1
Logic Control Box	3 - 1
Removing Logic Control Box Covers	3 - 1
Replacing Upright PCBs	3 - 2
Replacing The Computer Motherboard	3 - 3
Low Voltage Driver PCB Replacement	3 - 5
Computer Keyboard Replacement	3 - 6
Monitor Replacement	3 - 7
Disk Drive Replacement	3 - 7
Removing Front Panels And Covers	3 - 8
7-Button Keypad Replacement	3 - 9
Replacing Start/Stop and Emergency Switches	3 - 9
Carriage Section	3 - 11
Sash Frame Removal	3 - 11
Replacing X and Y Drive Belts	3 - 11

Under Carriage Section	3 - 13
X Motor And Motor Belt Replacement	3 - 13
Y Motor And Motor Belt Replacement	3 - 15
Replacing Motor	3 - 16
Replacing Belt	3 - 16
Power Supply Assembly	3 - 18
Motor Drive Modules	3 - 19
Setting Current Limit Switches	3 - 20
Embroidery Heads	3 - 21
Arm and Bed Assemblies	3 - 21
Z Motor Replacement	3 - 21
Tensioner Assembly Panel Removal	3 - 23
Pre-Tensioner	3 - 24
Replacing An Individual Thread Tensioner	3 - 24
Changing A Check Spring	3 - 25
Replacing Other Thread Tensioner Parts	3 - 26
Replacing A Thread Break Contact Post	3 - 27
Replacing The Thread Break Contact Brush	3 - 28
Replacing A Needle Bar	3 - 28
Needle Case Removal	3 - 31
Installing Needle Case	3 - 33
Replacing Needle Case Cross Roller Bearing	3 - 34
Reciprocator Replacement	3 - 35
Jump Stitch Solenoid Replacement	3 - 36
Color Change PCB Replacement	3 - 38
Color Change Motor and Belt Replacement	3 - 39
Grabber Motor and Belt Replacement	3 - 40
Grabber Motor ONLY	3 - 41
Grabber Belt ONLY	3 - 42
Grabber Blade Replacement	3 - 43
Grabber Replacement	3 - 44
Grabber Disassembly	3 - 46
Movable Knife	3 - 47
Movable Knife Drive Arm	3 - 48
Spring Knife Replacement	3 - 49
Picker Replacement	3 - 50
UTC Replacement	3 - 51

This page intentionally left blank

1. Introduction

Scope Of Manual

The EMC 10/12 Technical Manual is designed to provide the user with the information necessary to perform repairs and adjustments beyond routine operator maintenance.

This technical manual is presented in three basic sections: 1) an overview of general information found in this introductory section, 2) service adjustments, and 3) mechanical disassembly and replacement of the major components of the machine.

Conventions Used In Manual

The following is a list of some of the more commonly used conventions found in this manual:

When referring to keys on the user station standard keyboard, the key is simply referred to in the text as the exact name given on the key. For example: "Press the Enter key to initiate the action."

To choose one of the on-screen menu choices with the trackball, you will be directed to position the cursor over the appropriate box and press the left trackball control button. This is referred to as either clicking or selecting. For example: "Click on the Control Panel box." or "Select Head Timing."

Explanation Of Symbols



Caution!



Indicates a machine component will move. Keep clear!



Shock hazard. No user replaceable parts behind this label. Do not open!



Pinch point, Keep clear!



Pinch point, Keep clear!



Pinch point, Keep clear!

Glossary Of Terms

Several words or terms are used in this manual that are unique or specialized in use with the embroidery industry or Melco embroidery equipment. A glossary of these terms is located in the appendix section of the EMC 10/12 Operation Manual. Refer to that appendix for possible information on terms that may be unfamiliar to you.

Maintenance Philosophy

The maintenance philosophy used in this manual, and practiced at Melco, is to isolate potential problems within the system to a "practical" replacement assembly. Therefore, components are typically not repaired, but rather, a circuit board or mechanical "assembly" may be replaced. In the process of isolating problems in the machine, the person performing the trouble shooting must also practice good trouble shooting techniques. Good trouble shooting techniques include, but are not limited to, guarding against static electricity causing damage to machine components.

Static Electricity And Grounding Strap Use

The EMC 10/12 electronic circuits are quite sensitive to static electricity. Melco recommends that personnel use anti-static techniques when performing maintenance on the EMC 10/12.



Failure to use a grounding strap, or failure to practice other good maintenance or repair techniques may cause damage to the machine and possible harm to personnel.

Warranty Considerations

Some areas of maintenance require factory-trained personnel to assure proper service. If unauthorized personnel attempt to service these areas, the **FACTORY WARRANTY MAY BE VOIDED!**

Therefore, it is recommended that Melco factory-trained personnel be consulted whenever the "FACTORY SERVICE ADVISED" statement is noted with a procedure.

Although areas marked specifically for factory service are subject to voiding the warranty if performed improperly, any service that is improperly performed may cause the warranty to be voided.

System Overview

The EMC 10/12 Embroidery Machine is a twelve head machine assembled with Melco's ten needle, cylinder arm embroidery heads. The machine is designed for embroidering on flat goods, as well as with cap frames, cylinder hoops, and a sash frame. It is equipped with automatic thread trimmers.

Physical/Functional Arrangement

The EMC 10/12 may be divided into several distinct physical and/or functional areas of description. One of these areas is where all the computerized controls are housed; this area is called the User Station.

The user station is located to the far right of the embroidery heads and consists mainly of the computer items such as the monitor, keyboard, disk drive unit, and the controller box containing the various printed circuit boards.

A second section of the EMC 10/12 is Head Section. This section consists of each of the 12 embroidery heads, the Z drive system and associated head drive mechanics, the color change system, thread handling system, and other various parts making an operational embroidery head, including the trimmer devices.

Another area, the Carriage Section, consists of the mechanical devices that hold the garments and move them forward and backward (y axis movement) and left to right (x axis movement). The visible part of the carriage assembly is located just above the table top and positioned under the embroidery head arms. The carriage section also consists of the motors, drive belts, pulleys, and shafts associated with the device, located within or directly under the table top.

The Under Carriage Section is described as that area under the head platform and within the frame support. The under carriage section contains the power supply assembly.

It should be noted that Sections 2 and 3 of this manual are laid out in accordance with the above machine functional/physical descriptions.

This page intentionally left blank

2. Service Adjustments

General

This section of the manual provides detailed information for performing machine adjustments required during maintenance or parts replacement. The procedures are guidelines for personnel practicing good maintenance and repair techniques.

It is recommended that some procedures in this section be performed by factory-trained personnel in order to obtain the best results. This reference is indicated by stating "FACTORY SERVICE ADVISED" at the start of the procedure.

Drive Belt Tensions

"FACTORY SERVICE ADVISED"



CAUTION! Damage to the machine may result if belt tensions are improperly performed.

All drive belts require specific procedures and tools for setting the proper tensions. If the tension settings are attempted without using the proper procedure and tools, machine components may be damaged. If a belt tension adjustment is needed, it is recommended that you contact your local factory-trained service representative.

The SEEM C.Tronic 87 Type 105 Belt Tension Gauge

In each belt tensioning procedure of this manual where the SEEM C.Tronic 87, Type 105 belt tension gauge is used, refer to following information. This is a general method for using the tool. Refer to the applicable belt tensioning procedure for the proper tension setting for that belt.

1. Refer to the procedure in this manual applicable to the belt you are tensioning to identify the location for positioning the gauge.
2. Place the gauge onto the belt with the center rod resting in the tooth recess on the underside of the belt and the two outside rollers resting on top the belt as shown in Figure 2-1. The edge of the belt should be touching the flange of the rollers.

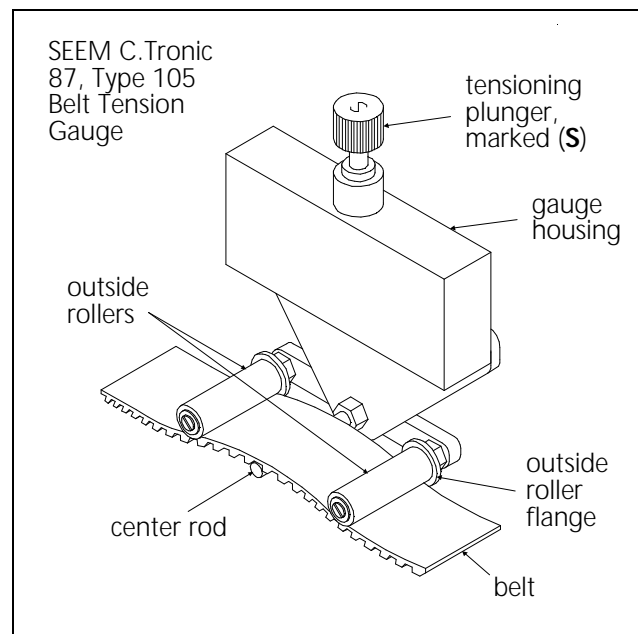

Figure 2 - 1

3. Check that the tensioning plunger marked "S" is installed in the top of the gauge housing, then rotate this plunger clockwise into the gauge until it is fully seated.
4. Attach the power cable to 120 Volts AC and observe the reading on the gauge indicator box.
5. Refer to the applicable belt procedure in this manual to adjust belt tension until the reading on the box matches the specified value for that belt.
6. Release the tensioning plunger by rotating it counter-clockwise until the gauge is easily removed from the belt.

Carriage Section

This section consists of the mechanical device and associated parts for securing and moving the hoops in the x and y coordinates during the stitching process.

X and Y Drive Belt Tensions

"FACTORY SERVICE ADVISED"

Note: This procedure requires using the SEEM C.Tronic 87, Type 105 belt tension gauge. Refer to page 2-1 for user instructions for this device.

The following procedure is for either the X or Y carriage drive belts. Figure 2-2 is simply a representative sketch of any one of the belts, showing only the area between the outer belt clamping block and the shaft pulley.

1. Turn the machine power switch OFF.
2. Remove the table sections over the Y belts and the roller blind over the X belt.
3. Position the carriage assembly all the way forward (for Y belts), and all the way to the left (for X belts).
4. Refer to the procedure in Section 3 of this manual for Replacing X and Y Drive Belts to attach the new X or Y carriage drive belt.
5. After taking up the slack in the belt refer to the following steps for tensioning.

- Refer to the procedure for attaching the SEEM C.Tronic 87, Type 105 belt tension gauge on page 2-1 and attach the gauge to the belt midway from the edge of the outer belt clamping block to the center of the drive shaft pulley (see Figure 2-2).

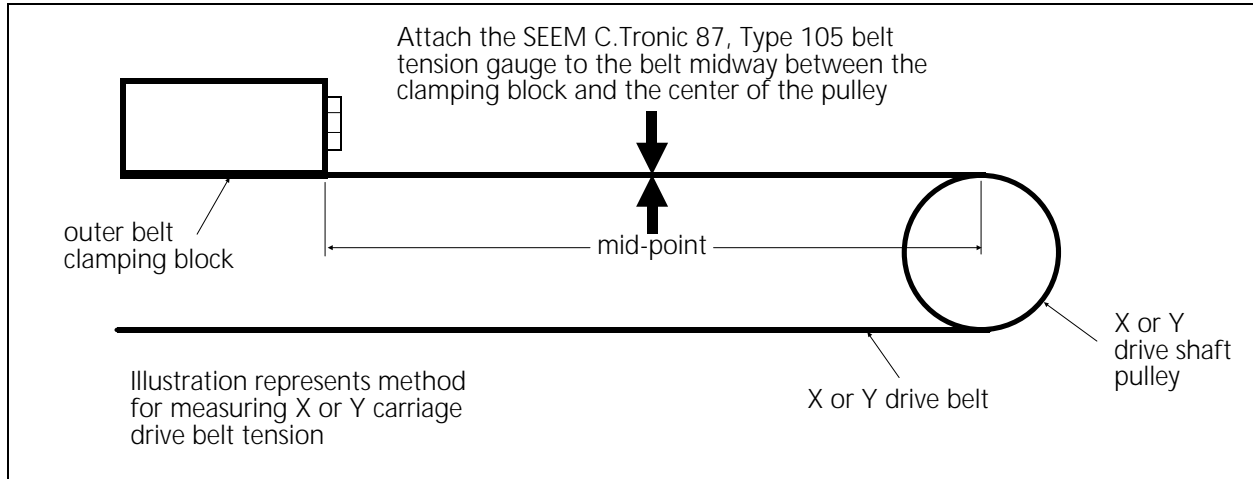

Figure 2 - 2

- Refer to Figure 2-3 for the readings on the indicator box for each specific belt.

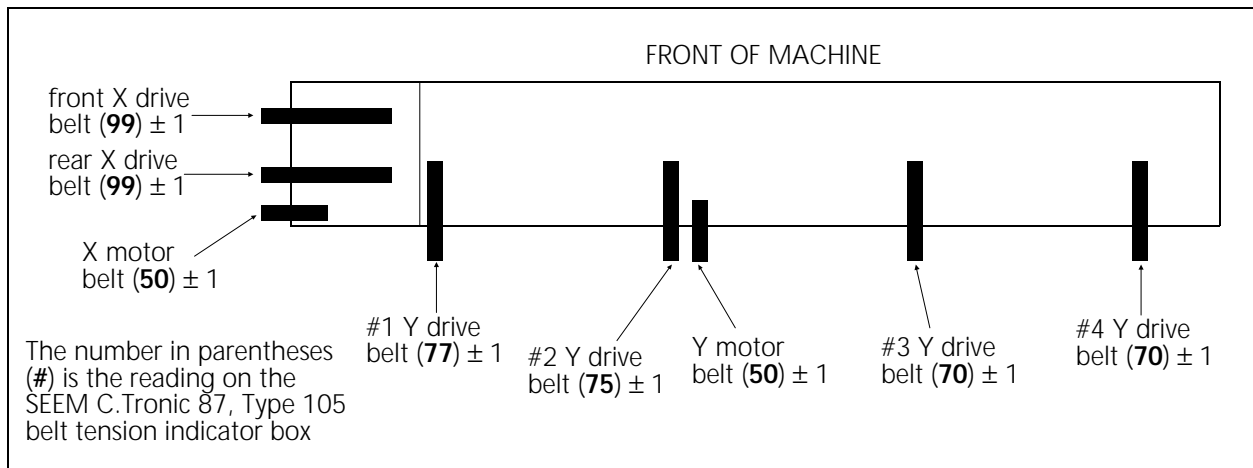

Figure 2 - 3

8. Refer to Figure 2-4, and loosen the hex bolt lock and the four set screws locking the dowels.

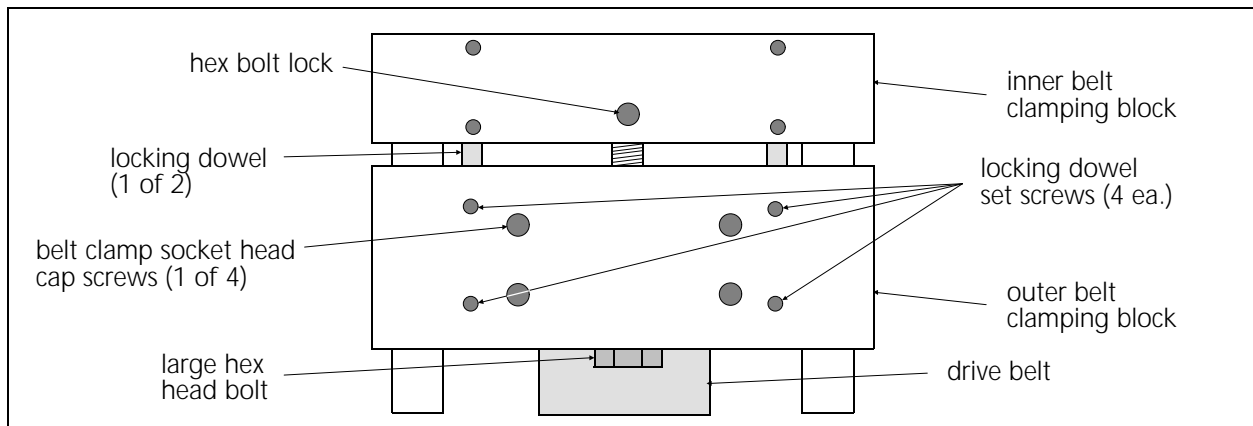

Figure 2 - 4

9. Rotate the large hex head bolt with a 5/8 inch wrench to obtain the correct tension reading at the indicator box. Rotate clockwise to increase the tension or counter-clockwise to decrease the tension.
10. Move the belt tension gauge to the other side of the belt and check the value at the indicator box. If the reading is correct and the same as the other side of the belt, go to step 12, if not, go to step 11.
11. If the two readings vary by more than 2 units on the indicator box, loosen the belt clamp on the side of the belt with the highest reading and adjust until both sides read within 2 units. Retighten the belt clamp.
12. Tighten the 4 locking dowel screws and the hex bolt lock.

Under Carriage Section

This section is physically located in and about the machine support framework. The X and Y motors are attached under the embroidery head platform and the power supply is found inside the frame support.

X and Y Motor Belt Tensions

"FACTORY SERVICE ADVISED"

Note: This procedure requires using the SEEM C.Tronic 87, Type 105 belt tension gauge. Refer to page 2-1 for user instructions for this device.

The following procedure is for either the X or Y motor belts. Figure 2-5 is a representative sketch of either of the motor belt areas, showing only the motor pulley, drive shaft pulley and belt.

Attach Motor and Belt

1. Put the motor belt in place and attach the motor to the motor mounting bracket. Tighten the motor bolts securely.
2. Snug the motor mounting bracket to the frame, allowing for movement within the slotted holes.
3. Rotate the tensioning hex bolt (located in line with the slotted holes in the mounting bracket) clockwise. This pulls the motor/bracket assembly away from the drive shaft, thus pulling the belt taut.
4. When the belt is believed to be close to the proper tension, tighten the motor mounting bracket bolts securely and prepare to check the belt tension.

Measure Belt Tension

5. Refer to the procedure for attaching the SEEM C.Tronic 87, Type 105 belt tension gauge on page 2-1 and attach the gauge to the belt midway from the center of the drive shaft pulley to the center of the motor pulley (see Figure 2-5).

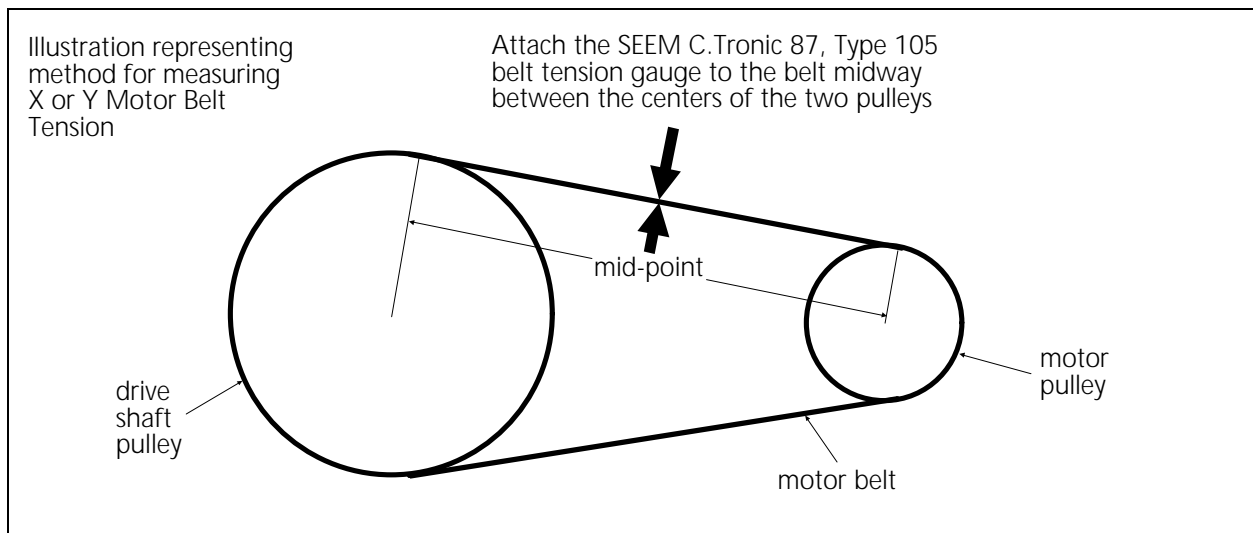

Figure 2 - 5

6. The reading on the indicator box for either belt should be 50 ± 1 (see Figure 2-3).
7. Loosen the motor mounting bracket bolts and rotate the tensioning hex bolt clockwise to increase the tension or counter-clockwise to decrease the tension. Tighten the motor mounting bracket bolts securely before making another tension reading.
8. When the tension reading is correct, move the belt tension gauge to the other side of the belt and check the value at the indicator box. If the reading is correct and the same as the other side of the belt, go to step 10, if not, go to step 9.

9. If the two readings vary by more than 2 units on the indicator box, align the motor pulley to the shaft pulley until both sides read within 2 units.
10. Tighten the motor mounting bracket bolts securely.

Power Supply Assembly

The power supply assembly consists of three independent supplies, the system operating voltage, the motor voltage, and the system logic voltage (see Figure 2-6).

System Operating Voltage

The non-logic system power is supplied from the unregulated +30 VDC power supply. This power supply provides a positive voltage that falls typically between +30 to +45 VDC. This voltage is not adjustable.

Motor Voltage

The motor voltage is supplied from the unregulated +160 VDC power supply. This power supply provides a voltage that falls typically between +150 to +180 VDC. This voltage is not adjustable.

System Logic Voltage

The power supply for all logic circuits other than the computer motherboard are also located in the power distribution box. This is a +5VDC voltage that is adjusted to within a specific voltage range for the machines logic circuits to operate reliably.

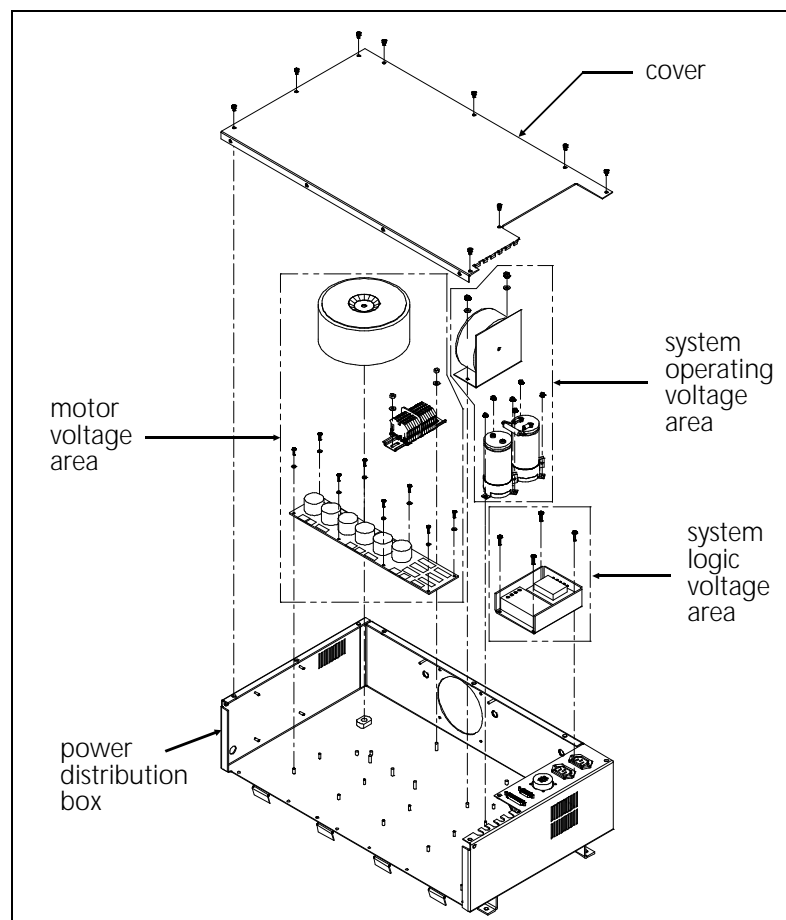

Figure 2 - 6

+5 VDC Adjustment

"FACTORY SERVICE ADVISED"



WARNING! Harmful voltages are present inside the logic control box and power supply assembly!

When performing the following voltage adjustment, use extreme care!

NOTE: The location for measuring the system logic voltage is in logic control box. The actual +5Volt system logic power supply is located in the power distribution box. (Do not confuse the computer power supply in the logic control box with the system logic power supply.)

- Measurement**
1. Turn OFF the EMC 10/12 Embroidery machine.
 2. Remove the outer cover, then the inner cover of the logic control box (see Figure 2-7).
 3. Locate the two test points on the vertically mounted connector PCB. They are labeled 'VCC' and "GND'.

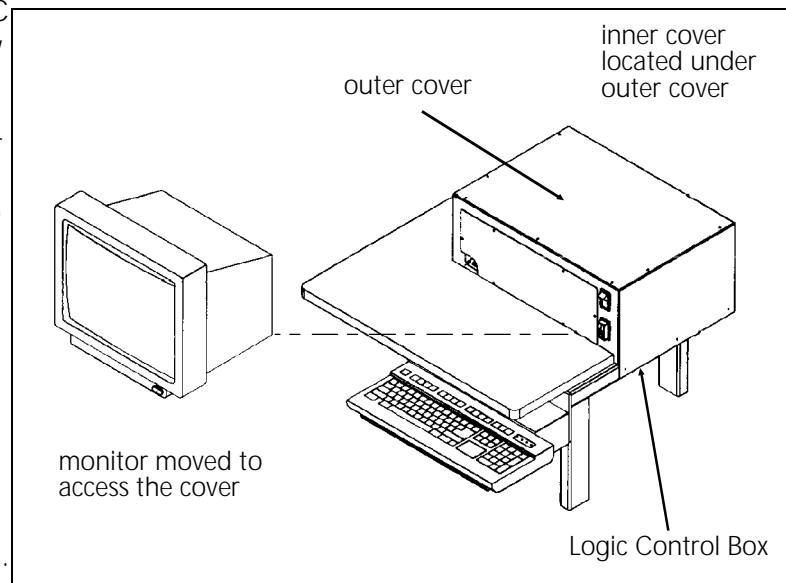

Figure 2 - 7

4. Attach your digital voltmeter leads to the test points, red to VCC and black to GND.
 5. Turn ON the power to the embroidery machine and observe the voltage reading on the digital voltmeter.
 6. If the voltage is between +5.00 and +5.10 Volts DC, stop here, turn OFF the machine again, and reinstall the logic control box covers.
 7. If the voltage is not within the range of +5.00 to +5.10 Volts DC, turn OFF the machine again and continue with the rest of this procedure.
- Adjustment**
8. Remove the captive screws in the heatsink of the power distribution box, then the nine screws fastening the top cover (see Figure 2-6). Lift off the cover.
 9. Refer to Figure 2-6 to locate the system logic power supply at the right end of the assembly.

10. Refer to Figure 2-8 and locate the +5 V adjustment potentiometer on the left edge of the system logic power supply as shown.

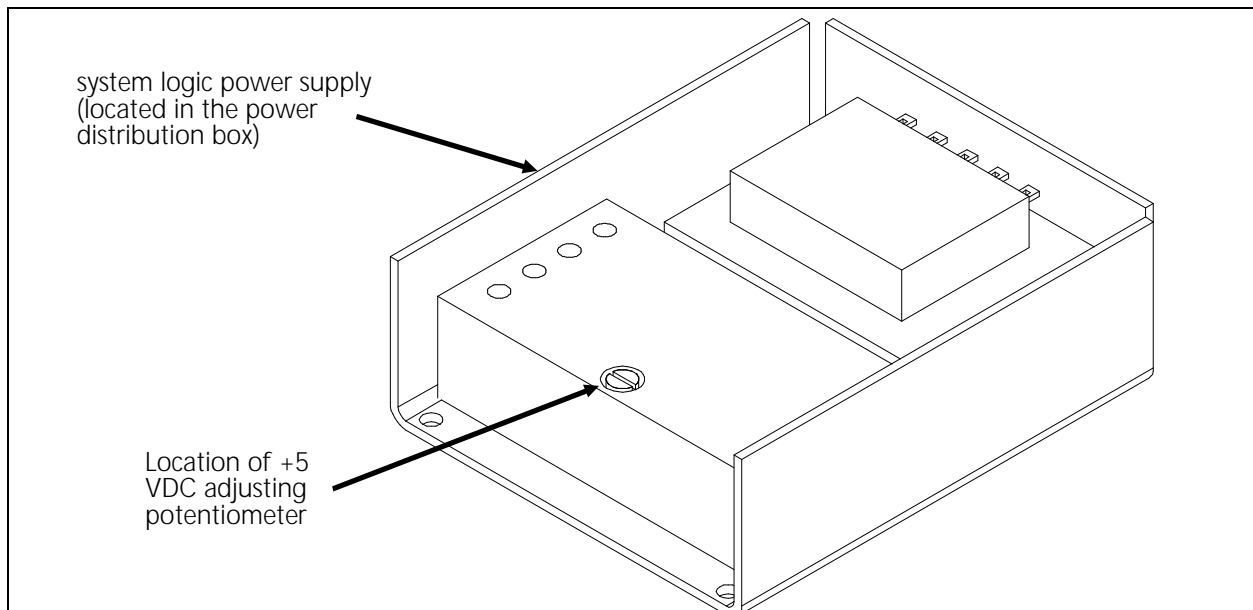

Figure 2 - 8



11. Turn the EMC 10/12 back ON.
12. With an insulated screw driver, carefully rotate the potentiometer clockwise to increase or counter-clockwise to decrease the voltage.
13. Monitor the voltage at the test points as you adjust the potentiometer until the voltage reads between +5.00 and +5.10 Volts DC.
14. Turn OFF the EMC 10/12 and remove the insulated screw driver and the volt meter.
15. Reinstall the power distribution box cover and the logic control box covers.

Embroidery Heads

Z Drive Mechanical System

The embroidery heads are driven by the Z drive system. This is a mechanical system of shafts, pulleys and gears driven by a single motor. Each head has two main shafts running through it. The upper shaft moves the needle, take up lever, and other associated parts and the lower shaft rotates the hook assembly. These shafts are connected by a belt at the rear of the head.

A bevel gear is attached to the rear of the upper head shaft of each embroidery head. Mating with each of these 12 embroidery head bevel gears are bevel gears attached to the Z drive shaft running horizontally along the back of the machine and aligning perpendicular to the rear of the heads.

The Z drive shaft consists of several pieces attached together with hex shaft couplers. At the right of the first head is the Z drive motor. Attached to the end of the motor is an in-line shaft encoder which detects rotational position of the shaft. Attached at the left end of the Z drive shaft is the trimmer cam drive belt, used to drive the trimmers at appropriate times.

The alignment and calibration of this mechanical system is critical for proper operation of the EMC 10/12 Embroidery Machine.

Setting The Shaft Couplings and Thrust Bearings

"FACTORY SERVICE ADVISED"

The four sections of the Z drive shaft are coupled together by in-line coupling mechanisms between heads 2-3, 6-7, and 11-12. The first shaft piece is connect to the motor shaft between the motor and the first head. To hold the axial position of the shaft, there is a thrust bearing set and collar on the outside and inside of the gear box wall of head number one. Head numbers three and seven also have a thrust bearing set and collar, but on the outside only.

Before you make any other adjustments to the Z drive system, you must first check that each of the Z shaft sections are securely coupled together and that the thrust bearings are set properly.

1. At each shaft coupling, check that the coupling nuts are tight and the shafts are securely held to each other with no allowable twisting movement at the coupling.
2. Remove the gear box cover from head number one to access the thrust bearing set attached against the inside wall (see Figure 2-9).

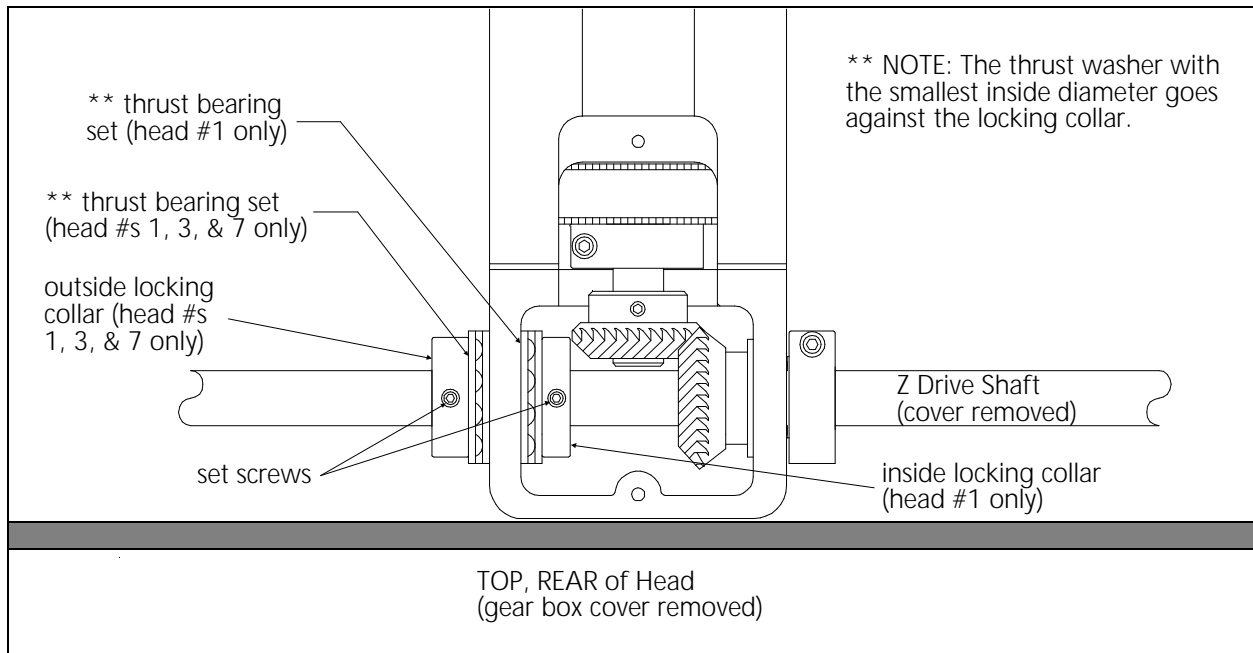

Figure 2 - 9

3. Check for any axial movement of the shaft at this location. To adjust looseness in axial movement at head number one:
 - a) Loosen the set screw in the locking collar on the side of the gear box wall where the thrust bearing is not tight against the wall surface.
 - b) Hold the thrust bearing and locking collar on the opposite side of the gear box wall tight against the wall and move the thrust bearing and loosened locking collar tight against the gear box wall. Retighten the set screw.
4. After adjusting axial movement at head one, check heads three and seven for any other thrust bearing set that is not tight against the outside wall surface. Correct as needed by loosening the locking collar and sliding it and the thrust bearing set tight against the wall.

After making any adjustment to the Z shaft couplings or the thrust bearings, you must check the head synchronization and gear mesh in the next two procedures and adjust as needed.

Synchronizing The Heads

"FACTORY SERVICE ADVISED"

NOTE: This procedure requires the use of a special Melco service tool: the Melco 10 needle head up fixture (p/n 995673-01).

Head synchronization is very critical in maintaining proper stitch timing for all the embroidery heads. The embroidery quality for any head that is not in sync with the rest will become very marginal, if it makes stitches at all. To synchronize the heads, refer to the following procedure:



1. Turn ON the EMC 10/12 and go to the service dialog box.
2. Click the "1 Rev or To Headup" button to ensure the machine is set to 110 degrees (the head up position).

At head up, all 12 heads must be at the same rotational position (110 degrees). If one or more heads are not "in sync" with the others, you must synchronize the head or heads that do not conform.

3. Remove the Z shaft cover and rear covers of the heads that are to be synchronized.

NOTE: It is IMPORTANT to insure that the Z drive shaft remains locked at the head up position during this procedure. The shaft is locked when the machine is ON and the Release button in the service dialog box is NOT checked.

4. While the machine is at head up, adjust all the non-synchronized heads to the mechanical head up position by using the Melco 10 needle head up fixture (p/n 995673-01) as described in the next few steps.
5. Move the cableway in front of the thread tensioner brackets forward to allow access to the head up alignment hole in the top of the head needing head up alignment (see Figure 2-10).

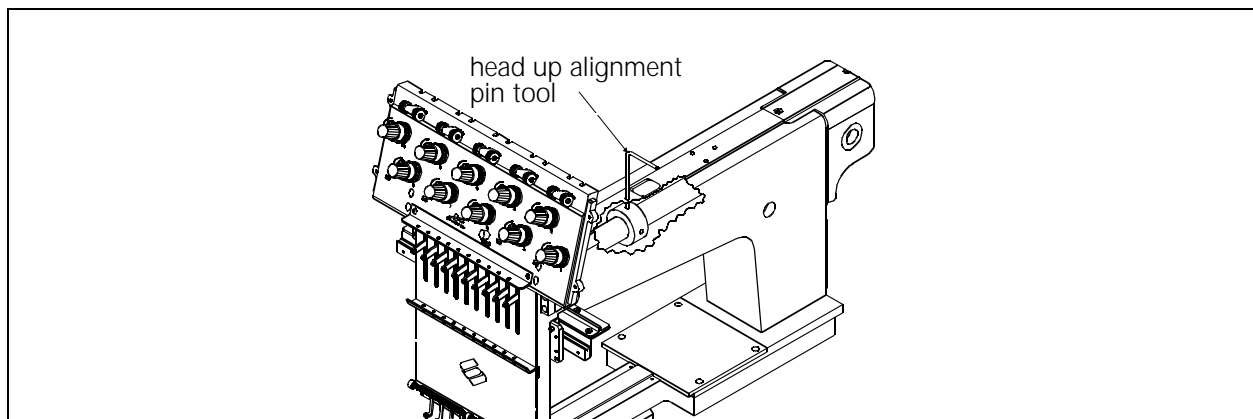

Figure 2 - 10

6. Position the head up fixture into the head up alignment hole.
7. Loosen the socket head cap screw in the locking collar of the bevel gear on the Z drive shaft associated with the head to be synchronized (see Figure 2-11). This will loosen the grasp of the Z drive shaft on the head.

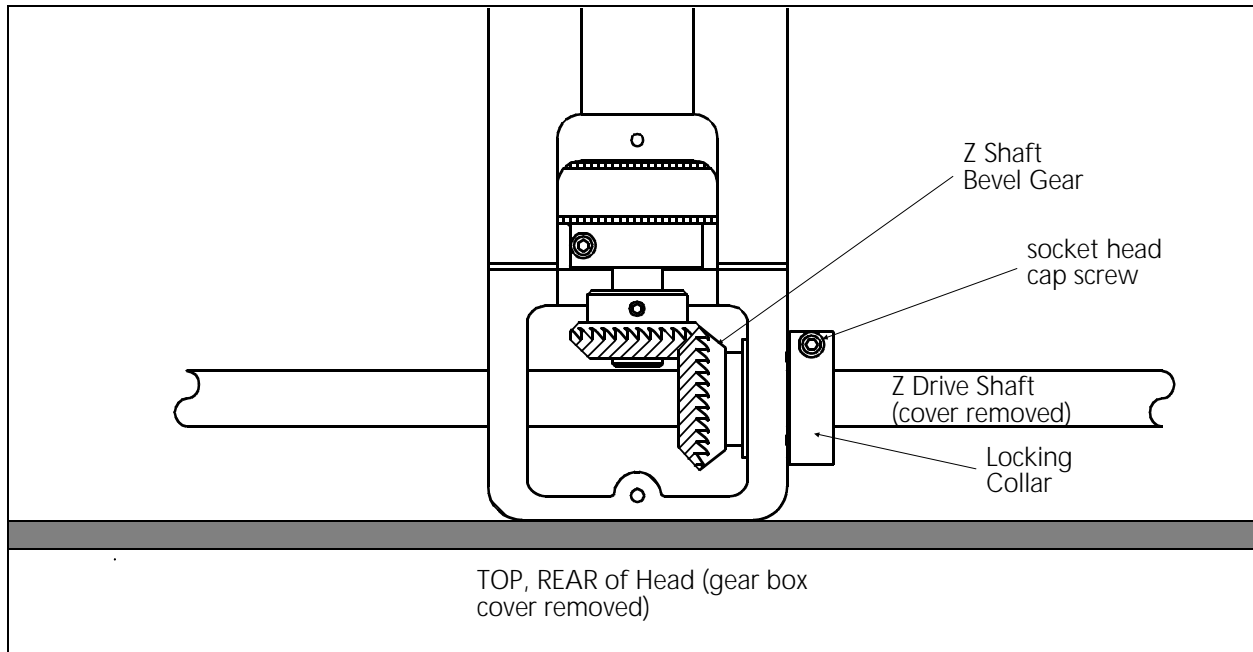

Figure 2 - 11

8. Rotate the head upper shaft (holding the Z drive shaft at head up) until the head up alignment tool will insert into position at the head's mechanical head up.
9. Refer to the gear mesh section below and retighten the locking collar of the bevel gear on the Z drive shaft. This will secure the head position.

Shaft Drive Gear Mesh

Engaging the bevel gears on the Z drive shaft and the mating bevel gear on each of the 12 embroidery heads must be a sound mechanical union. The coupling relationship between these gears is called the gear mesh.

The gear mesh must be tight enough to avoid excess "backlash" between the gears, while not binding (approximately .003 to .005 inch gear spacing).

When adjusted properly, you should be able to "feel" the free movement between the mating gears, while you may not be able to "see" the movement.

IMPORTANT! When a head is re-synchronized, you must check and adjust the hook timing (if needed) on that head. Refer to the hook timing procedure in the EMC 10/12 Operation Manual.

Z Encoder System Introduction

The ability to place stitches precisely at high speed is dependent on the accurate operation of the electronics and electromechanical assemblies. The "key" to this is the Z encoder. The information provided to the CPU and other PCBs by the Z encoder is the basis for all the embroidery head activity.

The CPU interprets the Z encoder signals to determine position, speed, and head up.

The CPU uses this information to determine when to move the carriage, when to stop embroidering for a color change, how fast the embroidery heads are running, how many stitches have been embroidered, etc.

The operational software handles the motor control circuitry differently when the Z axis is running than it does when the Z axis is stopped. When running, the motor control circuitry allows the X, Y, and Z axis motors only minute errors in rotation. Any error greater than the allowed error will cause the motor to be driven to eliminate the error.

Z Encoder Inspection

This procedure is a guide for the technician in determining if there is any signal response getting from the Z axis encoder to the machine CPU. If the inspection is inconclusive, you are advised to contact your local Melco service representative for service. If unauthorized personnel attempt to service this area, and the work is improperly performed, the FACTORY WARRANTY MAY BE VOIDED!

1. Remove the logic control box inner and outer covers and the first cover segment of the Z-axis drive shaft.
2. Locate the two red LEDs and one green LED on the top, left edge of the machine CPU printed circuit board (see Figure 2-12).

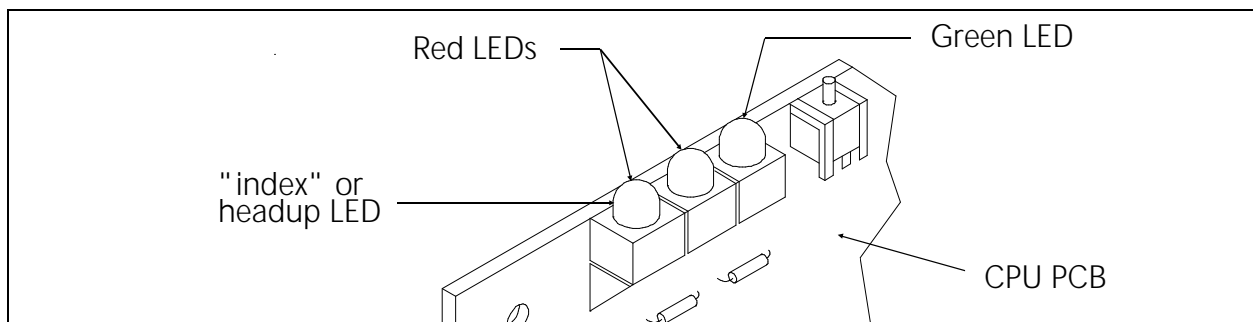

Figure 2 - 12

The first red LED on the CPU, can be used by the technician to see if the CPU is in fact receiving an index, or head up pulse from the encoder (indicating that the encoder and associated cables are functional). It should be noted however, that "the headup LED does NOT have to be ON when the machine is stopped, and the LED CANNOT be used to make a determination of the Z encoder alignment status."



1. Go to the service dialog box and click the "1 Rev or To Headup" button to ensure the machine is set to 110 degrees (the head up position).
2. In the service dialog box click the 'Release" button to unlock the hold on the Z shaft and allow manual rotation of the shaft. A check mark will appear in the check box next to the Release button.



3. Rotate the heads manually in a clockwise direction either by hand at the coupling of the Z motor and Z shaft or with the hex wrench at the left end of the Z shaft.
4. While rotating the head, check that the first Red LED blinks once for every revolution. This is the "index" or headup mark.
5. In the service dialog box click the 'Release" button again to remove the check mark from the check box and again lock the Z shaft from being able to be rotated mechanically.

IMPORTANT: If the above test fails or is in question, it is recommended that you consult with a Melco trained service representative. The number of fault possibilities are many, ranging from a defective encoder disc to a problem in the CPU, or even a broken wire in a harness between the two.

Note: The Z encoder is not replaceable separately. It is an integral part of the Z motor assembly, which must be replaced for a defective encoder.

Z-Axis Encoder Calibration

"FACTORY SERVICE ADVISED"

The Z-axis encoder position is set at the factory and most likely will not require any adjustment unless the Z motor is replaced. Should calibration become necessary, refer to the following procedure.

1. Turn the machine power ON. From the Advanced Features menu select Head Timing, followed by 1 Rev Or To Headup.
2. Click on the Release button. This will release the Z-axis shaft and allow manual movement. It will also display the shaft position in degrees.
3. Remove the tensioner panel above head #12 (refer to the Tensioner Assembly Panel Remover procedure in Section 3 of this manual).



- Using a dial indicator as shown in Figure 2-13, measure the total stroke of the needle bar while rotating the Z-axis shaft by hand in the forward direction. The total stroke of the needle bar should be within 1.946 to 1.984 inches.



- Divide the total stroke by two and rotate the Z-axis shaft by hand in the forward direction to that number (0.973 to 0.992 \pm 0.002 inches from the bottom of the stroke). This is the correct Z-axis position to set the head up position.

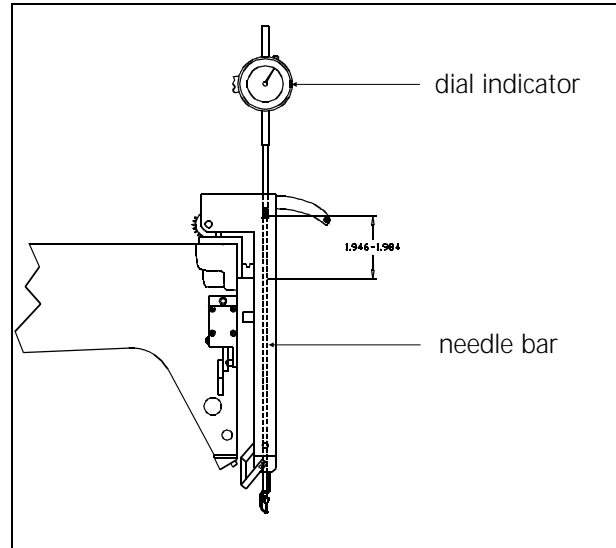

Figure 2 - 13

- In the service dialog box click the 'Release' button to again lock the Z shaft from being able to be rotated mechanically and remove the check box check mark.



CAUTION: The Z-axis encoder disc is easily damaged during the next few steps in this procedure, especially if the screws securing it to the encoder are **loosened too much**. **Melco is not responsible for warranty replacement of the Z motor assembly due to this failure during attempted calibration by untrained personnel.**

- Slightly loosen the encoder mounting screws just enough to be able to rotate the body of the encoder at the end of the Z motor assembly.
- Carefully rotate the encoder body until the monitor displays 257.0 \pm 4 degrees.
- Carefully retighten the encoder mounting screws.
- To verify the correct encoder position, click on 1 Rev or To Headup.
- Use the dial indicator to return to the "half stroke" position. The display should read 257.0 \pm 4 degrees.
- Reinstall the tensioner panel, Z shaft covers, and logic control box cover.

Thread Tensioner Check Spring Adjustment

After replacing a thread check spring, install the thread tensioner into the thread tensioner mounting bracket. You must then adjust the tension of the check spring against the thread break contact. To set this tension:

1. Slightly loosen the set screw in the top of the thread tensioner mounting bracket that secures the thread tensioner (see Figure 3-23 in Section 3).
2. Rotate the thread tensioner to the position where the check spring is just touching the left side of the thread break contact (brass post). See Figure 2-14.

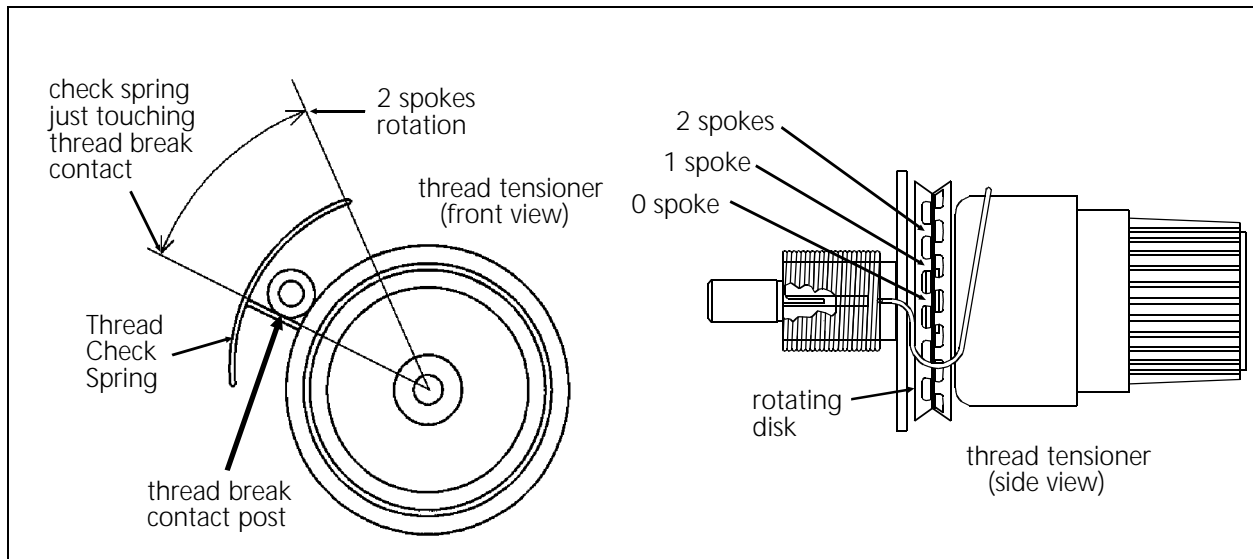

Figure 2 - 14

3. Observe the position of the thread tensioner check spring, then continue to rotate the thread tensioner clockwise the distance of 2 spokes of the rotating disk (see Figure 2-18). This represents 40 degrees rotation.
4. Tighten the set screw in the top of the thread tensioner bracket.

Adjustment Hints

The following is a discussion of embroidery quality issues with respect to the check spring adjustment:

As you exceed 2 spokes you may start to see deterioration of the tightening of the stitch due to a reduced rotational stroke of the check spring. A certain amount of stroke distance is required to take up the thread slack and cinch the stitch properly. If the check spring is too tight against the thread break post it will not retract far enough to make that stroke needed for a good tight stitch. False thread break messages may also occur with excessive rotation.

If you rotate less than 2 spokes you will begin to lose the force needed to make a tight stitch. You may have enough stroke but not enough force to cinch up the stitch tightly. You may also begin to have failure of thread break detection. You must have enough rotation to cause the check spring to make a good contact with the thread break contact post. A poor contact will often not provide the signal to stop embroidering when there is a thread break.

Cross Roller Bearing Centering

The cross roller bearing must be installed between the embroidery head v-rail and the needle case v-rail attached to the retainer plate. When these two are slid together and the retainer plate is centered on the head, the cross roller bearing must be centered (equal distance from each end of the rails).

1. With the needle case and retainer plate assembly removed, lay the cross roller bearing onto the embroidery head v-rail (see Figure 2-15). Orient the bearing with the welded edge down and position it to the right edge of the v-rail.

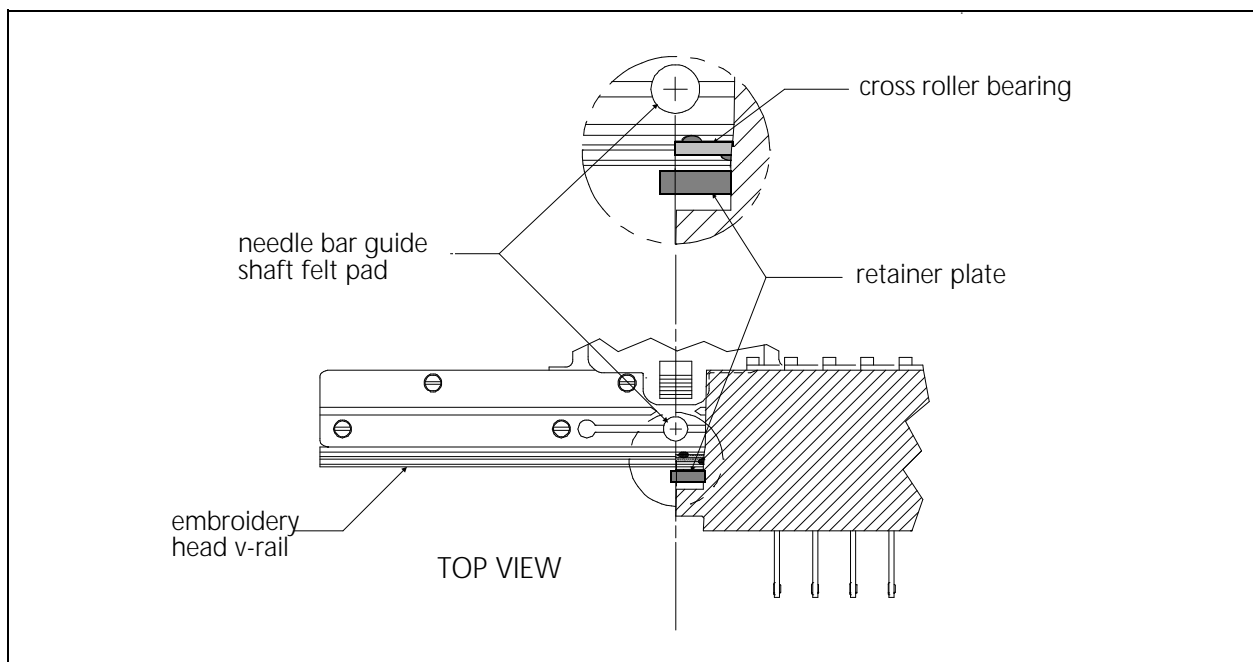

Figure 2 - 15

2. Place the retainer plate assembly onto the cross roller bearing at the right end of the embroidery head v-rail. (The needle case should be removed for easier adjustment.)
3. Slide the retainer plate assembly left to the point where the left edge of the retainer plate is aligned with the center of the needle bar guide shaft felt pad (see Figure 2-15).

4. Position the left edge of the cross roller bearing in line with the left edge of the retainer plate and the center of the needle bar guide shaft felt pad. (The second roller of the cross roller bearing should just be engaged between the embroidery head v-rail and the needle case v-rail.)
5. Slide the retainer plate assembly onto the embroidery head v-rail and cross roller bearing.
6. Check that the cross roller bearing is centered in the 2 v-rails by the following method:
 - a) Center the retainer plate assembly on the embroidery head v-rail.
 - b) Carefully insert a solid instrument, such as a straight allen wrench, into the opening at one end where the two v-rails join. Insert the instrument until it contacts the cross roller bearing. Do not force it any further.
 - c) Mark the position of the instrument at the end of the embroidery head v-rail, when the instrument is inserted to where it contacts the cross roller bearing.
 - d) Repeat this on the other side of the v-rails and compare the two marks. They should be very close to the same - within about 3/32 of an inch.
 - e) Repeat the above procedure for centering the cross roller bearing until the checking verifies it is within the proper tolerance.
7. Push the retainer plate assembly left and right as far as possible without the bearings coming off the end of the embroidery head v-rail. While moving the retainer plate assembly try to hold the bearings from rotating (one at a time) with your fingers. With a medium amount of pressure, you should be able to stop the bearing rotation.

Both bearings should require the same amount of pressure to prevent rotation or the cross roller bearing may migrate out of position.

8. If the test in step 7 shows an incorrect adjustment, refer to the next section, Retainer Plate Bearing Adjustment, to make the proper adjustment.

Retainer Plate Bearing Adjustment

Note: This procedure requires the use of a special service tool: the V-Rail Adjustment fixture (p/n 995675-01). To adjust without the fixture, refer to the Alternate Method at the end of this procedure.

1. Loosen the two socket head cap screws holding the needle case v-rail to the retainer plate assembly as indicated in the figure below.
2. Install the retainer plate assembly with the cross roller bearing centered between the 2 v-rails (see Cross Roller Bearing Centering on the previous page).
3. Install the v-rail adjustment fixture (p/n 995675-01) into the middle front hole of the retainer plate assembly as shown in Figure 2-16.

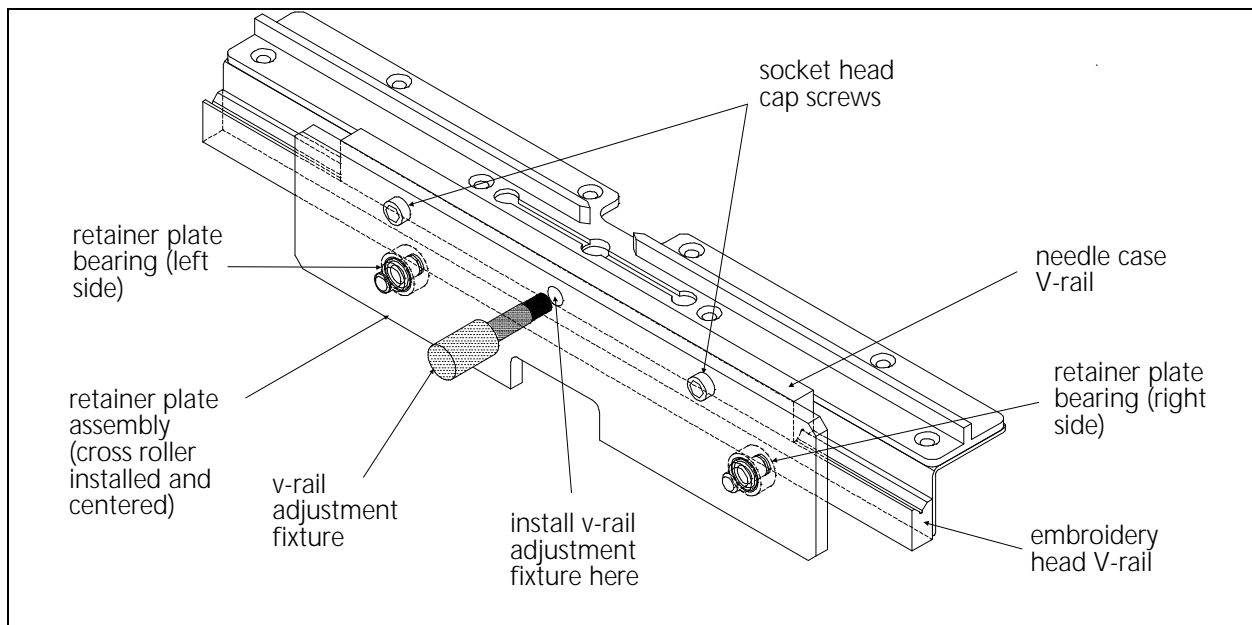

Figure 2 - 16

4. Snug the needle case v-rail to the retainer plate assembly very lightly with the socket head cap screws. Do not overtighten the screws or the fixture will be unable to perform its adjustment properly.
5. Carefully and slowly rotate the v-rail adjustment fixture (either clockwise or counter-clockwise) until you feel a slight resistance. The left and right retainer plate bearings should now be snug against the bottom of the embroidery head v-rail.
6. Tighten the socket head cap screws securely and remove the fixture.

7. Push the retainer plate assembly left and right as far as possible without the bearings coming off the end of the embroidery head v-rail. While moving the retainer plate assembly try to hold the bearings from rotating (one at a time) with your fingers. With a medium amount of pressure, you should be able to stop the bearing rotation.

Both bearings should require the same amount of pressure to prevent rotation or the cross roller bearing may migrate out of position.

8. If required, loosen the socket head cap screws and repeat this process until the bearings are adjusted as described in step 7.

Alternate Method

- A1. After steps 1 and 2, set the retainer plate in its approximate location and snug the two socket head cap screws as described in step 4.

- A2. Attach the needle case as described in Section 3 of this manual.

- A3. Check the bearing pressure as described in step 7.

- A4. If adjustment is needed, place a flat blade screw driver or similar instrument to wedge between the needle case side plate and the needle case V-rail.

- A5. Loosen the V-rail socket head cap screw on the side you are attending. (With the upper needle case cover off, you can reach the screw through the front of the needle case.)

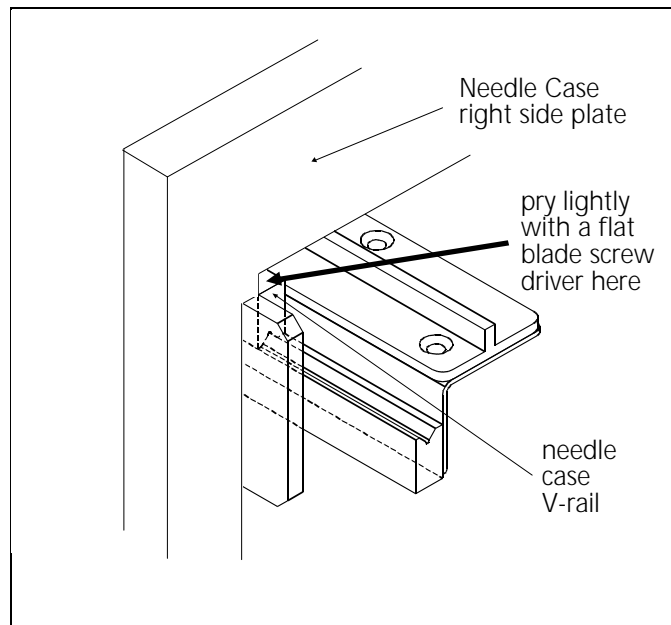

Figure 2 - 17

- A6. Lightly pry in this area and retighten the socket head cap screw.
- A7. Check the adjustment as described in step 7 and repeat until it is properly achieved.
- A8. Repeat the procedure for the bearing on the other side.

Lower Rail Retainer Adjustment

This adjustment affects the forward and backward movement of the bottom of the needle case. Do not make the adjustment so tight that you preload the roller bearing in the head so it wears prematurely. Do not have so much free play that the needle has excessive movement.

1. Install the needle case into the lower rail retainer and attach the needle case to the retainer plate assembly. Refer to Section 3 in this manual on installing the needle case assembly.
2. Loosen the screw under the lower rail retainer and push it towards the rear to remove the play between the retainer and the lower rail of the needle case.

Note: You will have to remove the grabber blade guide assembly of the trimmer system to access the screw.

3. When the gap between the needle case bottom rail and the embroidery head roller bearing is between zero preload and .002", tighten the screw under the lower rail retainer.

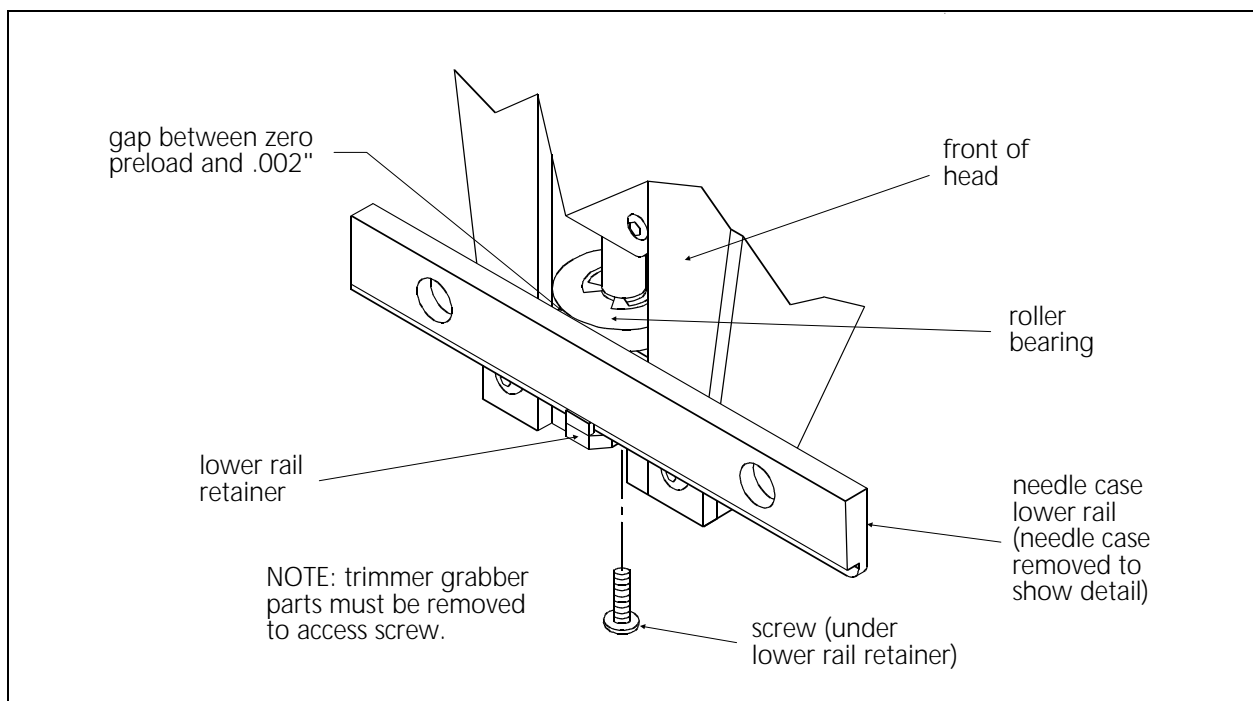

Figure 2 - 18

Jump Stitch Solenoid

If a jump stitch solenoid has been replaced, you may have to perform one or more of the adjustment procedures below:

NOTE: The needle case must be removed to perform the adjustment procedures in this section. See Section 3 for needle case removal.

Plunger Positioning

During the jump stitch solenoid replacement procedure in Section 3, you were to count the number of threads that are showing beyond the solenoid bracket. If this was not done, the following procedure will help position the solenoid plunger properly. There are two plunger positions of concern:

Plunger Position 1

The jump stitch solenoid must be positioned so that the plunger is close enough to actuate the needle bar driver reciprocator when the solenoid plunger is extended (solenoid de-energized).

Plunger Position 2

The plunger also must not be contacting the reciprocator during normal embroidery when the solenoid is energized.

A typical dimension for the gap between the relaxed solenoid plunger and needle bar driver reciprocator is approximately 0.015 to 0.045 inches (0.4 to 1.1mm).

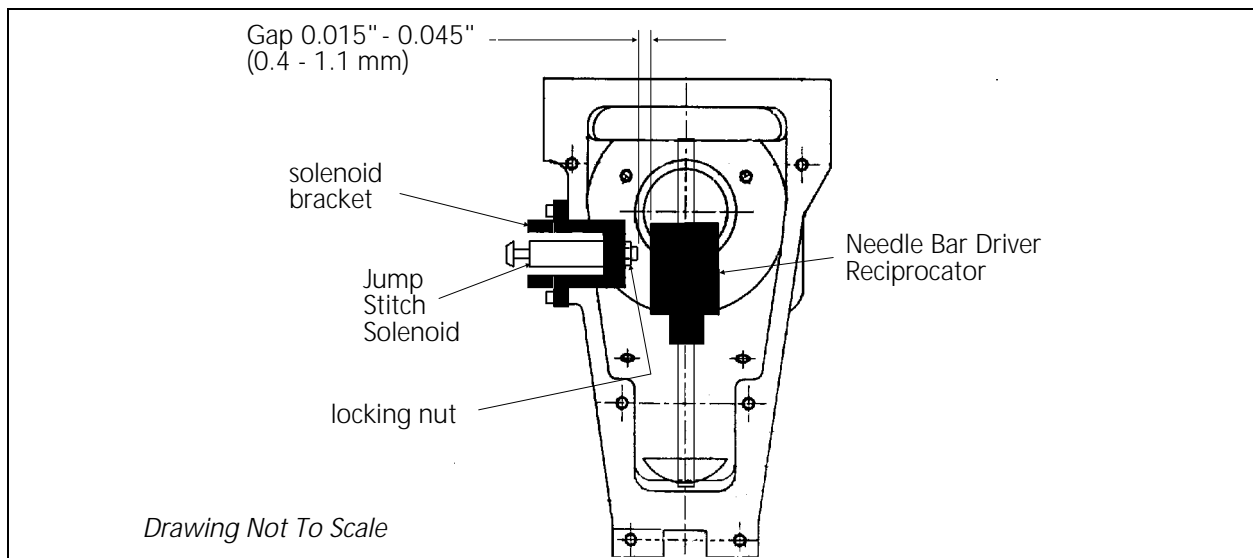

Figure 2 - 19

To obtain this gap, loosen the locking nut on the solenoid and rotate the solenoid inside the bracket until the gap is proper. Tighten the locking nut.

Bracket Positioning

When attaching the jump stitch solenoid and bracket, it is not only necessary to place the plunger correctly, but you must also position the assembly in the proper forward to backward relationship. There are three concerns in positioning the solenoid and bracket assembly:

Bracket Position 1

The solenoid and bracket assembly should be far enough forward so the plunger will cause the reciprocator to rotate enough to release the needle bar during the jump stitch cycle.

Bracket Position 2

The solenoid and bracket assembly must not be so far forward that it causes the reciprocator to rotate to its mechanical rotational limit. This may cause premature failure of the reciprocator mechanism.

Bracket Position 3

The solenoid and bracket assembly must not be so far backward that it contacts the embroidery head connecting rod during its mechanical motion.

To position the solenoid and bracket:

1. Put the new solenoid and bracket assembly in place and push it to the back of the cutout in the side of the embroidery head.
2. Attach it to the head with the 2 screws removed earlier, then check the alignment to be within the above 3 positions. Be sure that the plunger contacts the reciprocator mechanism, that the mechanism works properly, and that the jump stitch assembly does not contact the embroidery head connecting rod during its mechanical motion.
3. Attach the solenoid connector to the thread break harness connection coming from the harness channel above the embroidery head arm and behind the tensioners.

Note: The two wires coming from the solenoid body and connecting at the small black plastic connector, can be damaged if they are twisted together. Twisting the wires together will reduce their length and can put undue stress at the connections at both ends. We therefore do not recommend twisting these wires together. If you must group these wires together, use "cable ties" (plastic straps) these are available at most electronic supply stores.

4. Reinstall all covers removed to change the jump stitch solenoid and test embroider a large letter (6 inch block I, for example) to check the machine for proper jump stitch operation.

Color Change Motor Belt Tension

The color change belt tension should cause the color change cam to rotate with minimum backlash.



CAUTION! The belt should be tensioned with some amount of slack so it is not so tight that it wears the color change shaft and bushings needlessly.

Adjust the color change belt tension by loosening the four (4) color change motor mounting screws and moving the motor to make the belt more or less taut. When tightening the belt tension, use hand pressure only on the motor. No additional force is needed.

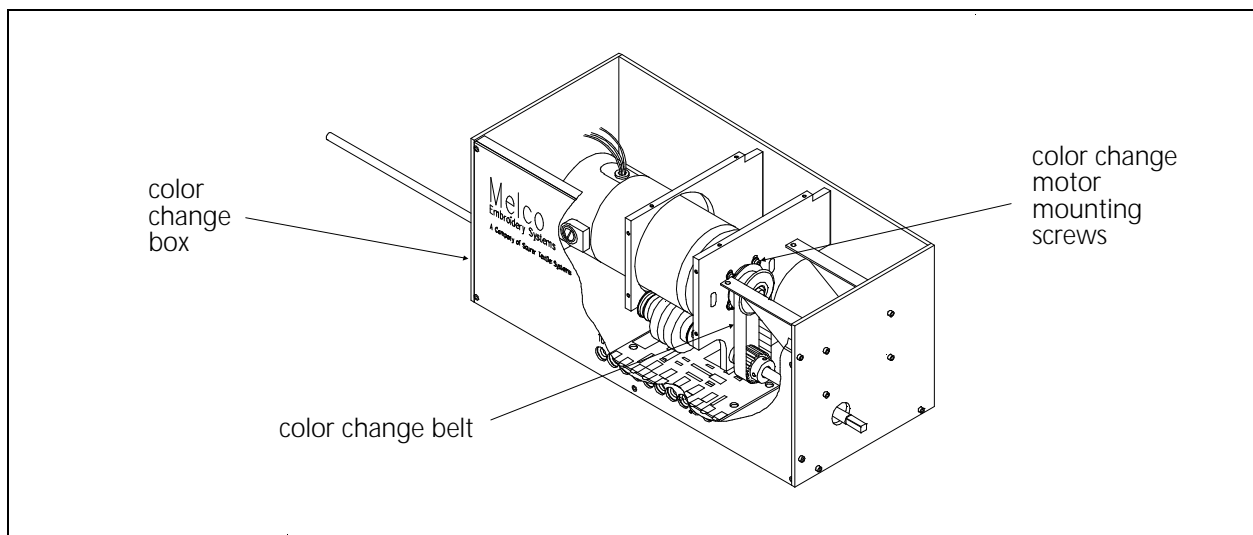

Figure 2 - 20

Color Change Link Bar Adjustment (Needle Centering)

If the color change link bar has been removed (to service the cross roller bearing or reciprocator mechanism for example) the needle case must be properly aligned or machine damage will occur. Refer to the following procedure for color change link bar adjustment.

NOTE: The needle case can be removed without removing or changing the color change link bar.

1. Remove lower front cover between the needle cases to access the color change link and attaching clamps.

2. With the needle case in place attach the color change link bars (refer to Figure 2-21). Tighten the top socket head cap screws on the bar clamps but do not fully torque them down. (Note that the lower cap screw holds the clamp to the needle case; the upper cap screw clamps the link bar.)

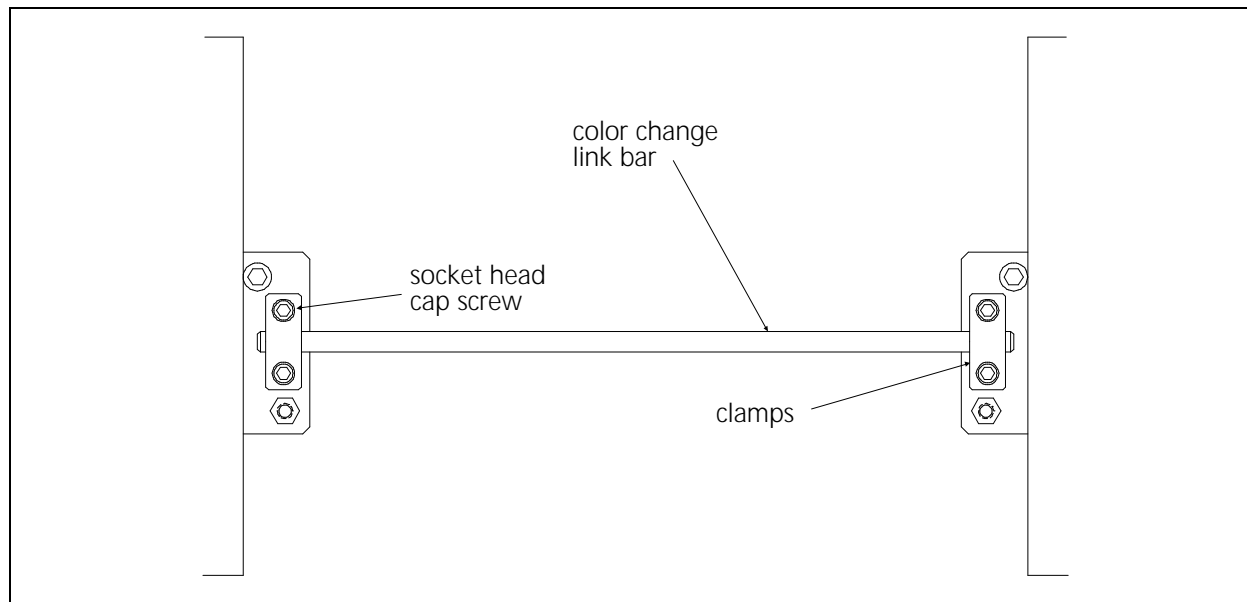





Figure 2 - 21

3. Deactivate the embroidery head to be adjusted by turning the head mode switch on the tensioner assembly panel to the OFF position. (Refer to the EMC 10/12 Operation Manual for more information on the head mode switch).
4. Turn the machine power ON.
5. Using the 8-button keypad, press   or   to move the needle cases to needle 5 or 6.



WARNING! Use care during the next steps to avoid injury.

6. Ensure the same needle position in each needle case is in approximate position directly over their respective needle plate holes.
7. Before checking for accurate needle centering replace the needle in the selected needle bar to ensure the straightness of the needle.
8. To check for proper needle center, manually push the selected needle bar down until the needle starts to enter the needle plate hole. The needle should be centered in the needle plate hole.
9. If the needle is not centered loosen the link bar clamp screws and carefully nudge the needle case from side to side until the needle is centered within the hole. Tighten the link bar clamp screws but do not torque them down.

10. Turn the head mode switch to AUTO.
11. Go to the Advanced Features menu and select Head Timing.
12. Select Bottom Dead Center to extend all needles.
13. Visually check the needle alignment within the needle plate hole. If the alignment is not correct, repeat steps 5 through 9.
14. If the needle alignment is acceptable, tighten the link bar clamp screws.
15. Check the remaining 11 heads, then replace all covers.

Thread Break Brush Adjustment

The thread break brush must be adjusted to make proper contact with the thread break contact posts coming off the rear of the thread tensioner assembly PCB.

1. Put the needle case in any selected needle position.
2. Loosen the thread break brush bracket mounting screws at the top of the head.
3. Position the thread break brush so it is centered directly under the selected needle thread break contact post coming from the thread tensioner assembly PCB.
4. Tighten the thread break brush bracket mounting screws securely.

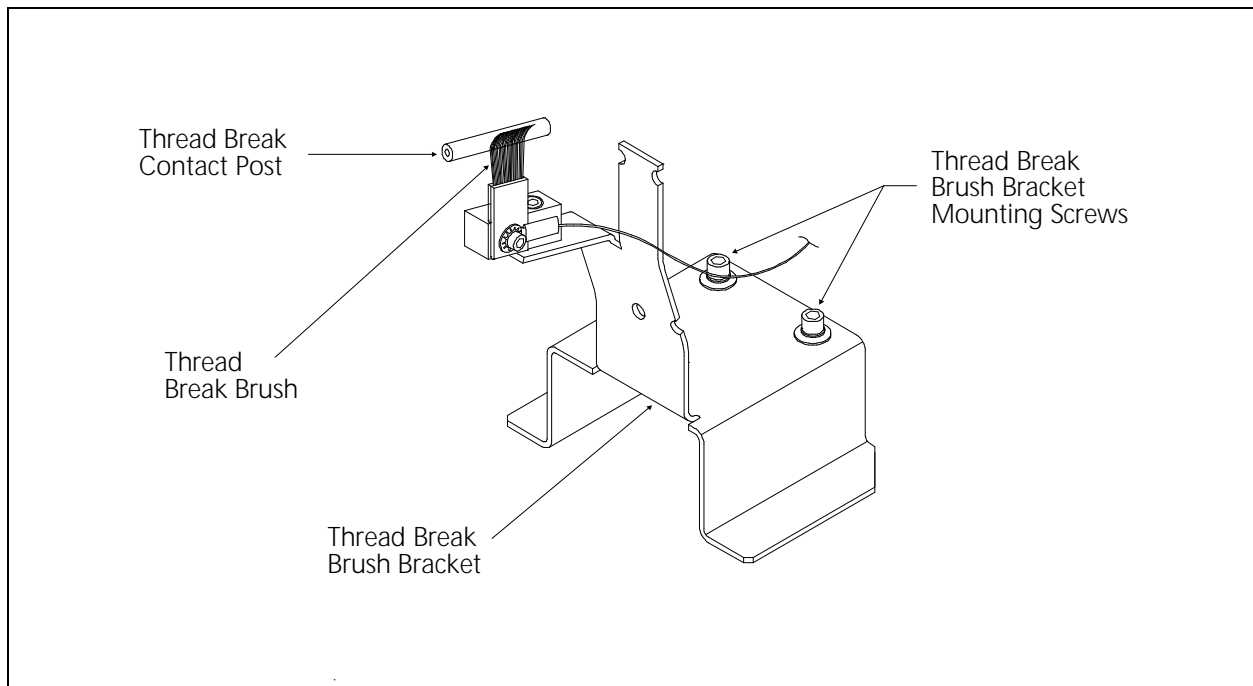

Figure 2 - 22

X and Y Stop/Limit Encoder Adjustments

"FACTORY SERVICE ADVISED"

A stop/limit encoder assembly is associated with the X and Y axes. The purpose of these assemblies is to stop the movement of the sash frame (or cap frames) at specified locations and limits. When changing the assembly drive belts it will very likely be necessary to readjust these stop/limit encoder assemblies.

Both the X and Y axes have a separate stop/limit encoder assembly attached to their mechanical drives. Inside each of these assemblies are 3 flags with varying degrees of material around their parameters. The flags are attached to a shaft which rotates with the movement of the X or Y motor.

Also found in these assemblies is a printed circuit board with three circuits for detecting movement of these flags. Each circuit has a photo cell and indicator LED. The LEDs will be OFF when the material from the associated flag interrupts the photo cell. When the material from the associated flag is not interrupting the photo cell, the LED will be ON.

To adjust the encoder assemblies, refer to the following procedure.

Center Index

The right hand flag inside the encoder assembly housing is the center index flag. One half of the flag is missing and the other half consists of the fully extended material. The flag is adjusted so that during sash frame movement on one side of the center line, the flag will be interrupting the photo cell and during movement on the other side of the center line the photo cell will not be interrupted.

1. Use a tape measure to position the front edge of the rear beam of the sash frame 177mm from the center of the needle plate hole.
2. Center the sash frame in the X (left/right) axis by positioning it so a straight line between the center of the rear hoop inserts and the front hoop insert crosses over the center of the needle plate hole.
3. Remove the covers from the X and the Y stop/limit encoder assembly housings.
4. At one of the encoder assemblies, loosen the set screw that holds the center index flag to the encoder shaft.
5. If the indicator LED is ON, slowly rotate the flag until it just goes OFF. If the indicator LED is OFF, slowly rotate the flag until it just goes ON.
6. Tighten the set screw.
7. Repeat the previous three steps with the other axis encoder assembly center index flag.

Cap Frame Limits

The middle flag inside the encoder assembly housing is for cap limits. In the Y axis, this flag actually consists of 2 flags set next to each other as shown in Figure 2-23. The flags are arranged so that a small part of the flag-set parameter is missing material and the rest consists of the fully extended material. During the movement of the cap frame within its accepted mechanical limits, the flag-set will not be interrupting the photo cell. The flag-set is adjusted so that when the mechanical limits are approached, the photo cell will be interrupted by the flag-set and the movement will be disabled. This will occur at each end of the axis movement.

Y Axis Adjustment (for standard or wide angle cap frames)

NOTE: The function of this flag-set is just the opposite from the flats limit flag-set.

1. Ensure the center index is set properly as described in the previous procedure, then position the sash frame to the center index.
2. Lower the table top and load a standard cap frame driver onto one of the heads. Attach a cap frame to the driver.
3. Remove the cover from the Y stop/limit encoder assembly housing.



CAUTION! Incorrect move values used in the following steps may cause damage to the cap frame mechanism.

4. At the middle flag location inside the encoder assembly housing, loosen the set screws that secure the cap frame limit flags and open the flag gap slightly at both edges. Snug the set screws to maintain the changed positions.

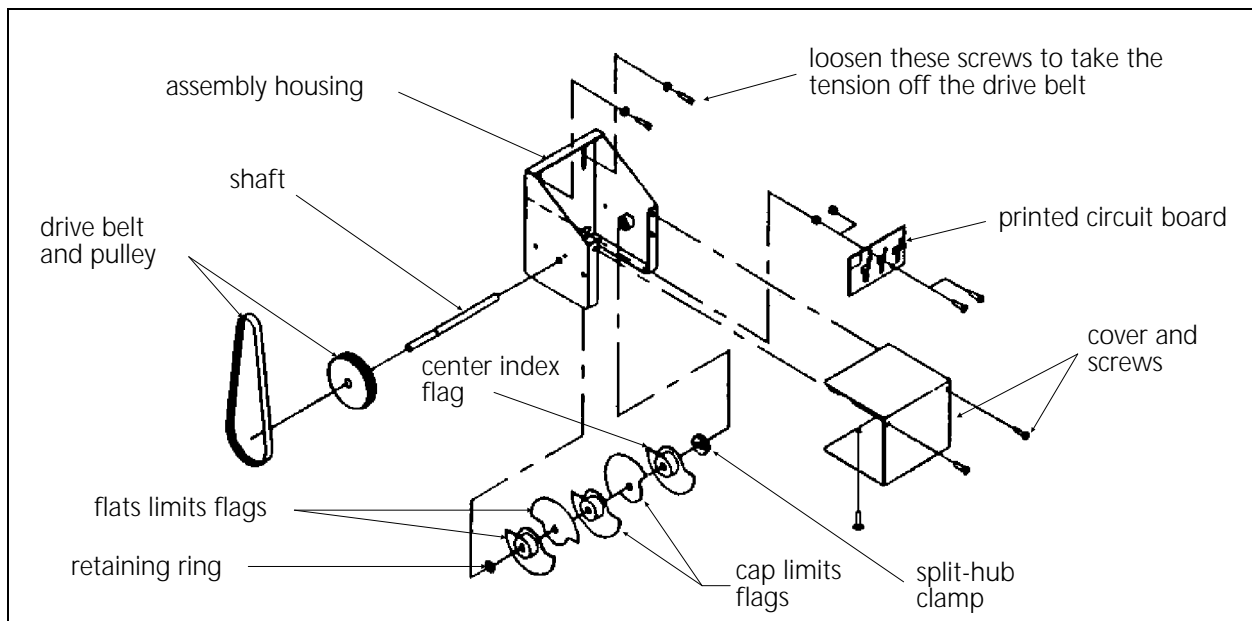

Figure 2 - 23 Y Limits Assembly



5. Be certain you are at the proper center index, then use the move feature in the operating program to move the cap frame to either the front or rear mechanical extreme of the cap frame movement in reference to the below:

Y axis dimension = 34mm both forward and backward from center index.

6. At the encoder assembly associated with the position moved to in the previous step, loosen the set screw that secures the cap frame limit flag for stopping the movement at this position.
7. Slowly rotate the flag until the photo cell is just interrupted by the flag material. When the photo cell is interrupted the associated LED will change states - If it was ON it will go OFF, it was OFF it will go ON.
8. When the flag is set to just where the LED changes states, tighten the set screw.



9. Repeat the previous four steps for the other cap frame mechanical movement extreme.
10. Reattach the Y stop/limit encoder assembly housing cover.

X Axis Adjustment (for standard cap frame only)

The X axis flag consists of a single flag on the main shaft (used with the wide angle cap frame) and a "slip-on" flag for use with the standard cap frame. Refer to Figure 2-24 and be certain the slip-on flag is installed and tightened with the thumb screw for standard cap frame operation.

1. Ensure the center index is set properly as described in an earlier procedure, then position the sash frame to the center index.
2. Lower the table top and load a cap frame driver onto one of the heads. Attach a cap frame to the driver.
3. Remove the cover from the X stop/limit encoder assembly housing.



CAUTION! Incorrect move values used in the following steps may cause damage to the cap frame mechanism.



4. Be certain you are at the proper center index, then use the move feature in the operating program to move the cap frame to either the left or right mechanical extreme of the cap frame movement in reference to the dimension below:

X axis dimension = 71mm both left and right from center index.

5. At the middle flag location inside the encoder assembly housing, loosen the set screw that secures the cap frame limit flag.

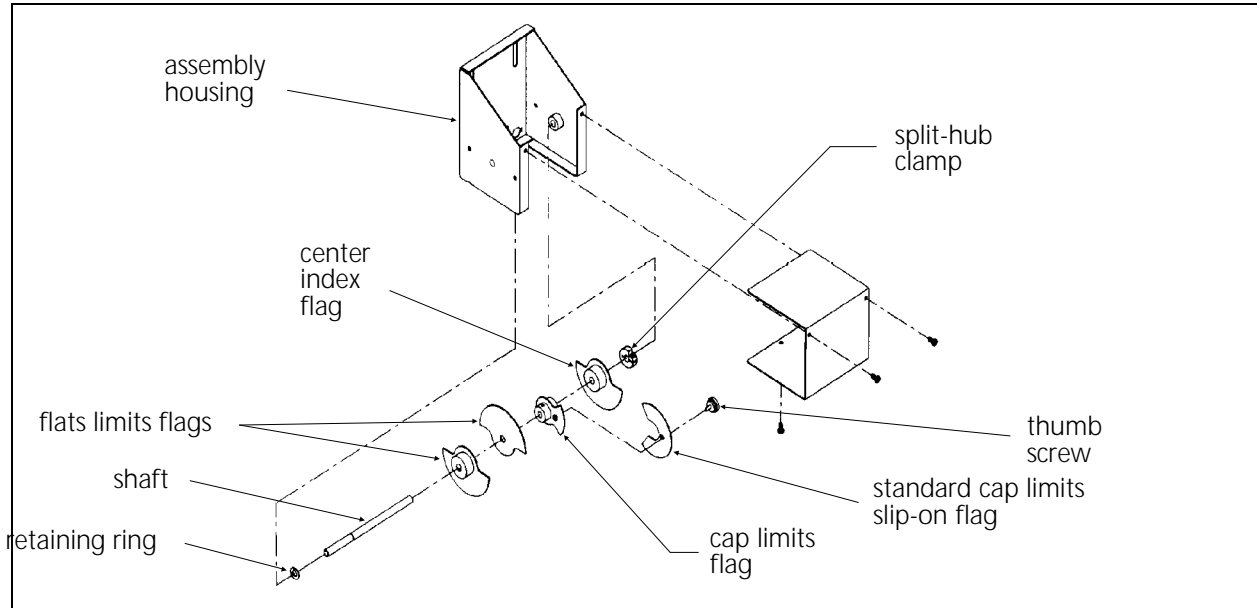

Figure 2 - 24 X Limits Assembly (w/ WACF Flag)

6. Slowly rotate the flag until the photo cell is just interrupted by the flag material. When the photo cell is interrupted the associated LED will change states - If it was ON it will go OFF, it was OFF it will go ON.
7. When the flag is set to just where the LED changes states, tighten the set screw.
8. Again, being certain you are at the proper center index, use the move feature in the operating program to move the cap frame to the other mechanical extreme of the cap frame movement in reference to the dimension below:

X axis dimension = 71mm both left and right from center index.
9. Check that the photo cell is just interrupted by the flag material at this extreme, just as with the other extreme in step 6.
10. If interruption of the photo cell is not the same at both mechanical extremes, adjust the move from center index slightly and repeat this procedure until the result at both extremes is the same.
11. Reattach the X stop/limit encoder assembly housing cover.



X Axis Adjustment (for Wide Angle Cap Frame only)

The middle flag (with the "slip-on" flag for the standard cap frame removed) is the new wide angle cap frame X limits "flag" (see Figure 2-24). The flag is arranged so a small part of the flag circumference consists of the fully extended material and the rest is missing material. During the movement of the cap frame within its accepted mechanical limits, the flag will not interrupt the photo cell.



CAUTION! Improper mechanical center index adjustment in the X axis and incorrect move values used in the following steps may cause movement into the mechanism limits of the machine.

1. Remove the cover from the X stop/limit encoder assembly housing.
2. Ensure you are at the exact X axis center index, then make a slight pencil mark on the table top piece under the workstation, indicating the right side of the sash frame sewing area screenprint plate.



3. Use Move in the Advanced Features window to move the frame to the left 183 mm (enter 18.3 cm for the value in X.)

4. After successfully moving in the previous step, loosen the set screw that secures the WACF limit flag and rotate the flag until the flag material just begins to enter at the top of the photo sensor and the associated LED goes OFF.
5. Slowly rotate the flag slightly back again until the flag material just comes out of the top of the photo cell and the LED comes ON.
6. Alternately rotate the flag back and forth into and out of the photo sensor until you are certain the position of the flag is just where the LED changes states from ON to OFF. Tighten the set screw.

7. Go to hoop center and install ONLY the cap frame driver shaft into the block under any of the heads to tell the machine that a cap frame driver is installed. DO NOT install the upper portion of the cap frame driver at this time.



8. Using the right arrow key, move the frame to the left until the frame limit stops the movement.

9. Measure the distance from the center index pencil mark made earlier on table top to the same reference on the screenprint plate that was used to make the mark. The distance should be approximately 183 mm to the left of index (note the measurement for reference in step 11 below).



10. Now with the left arrow key, move the frame to the right, past the center index and continue until the frame limit stops the movement to the right.

11. Again measure the distance from the center index mark to reference on the screenprint plate that was used to make the mark. The distance should be 183 mm to the right of index.

If the distances measured after the left and right jog moves above are not the same, readjust the flag to get them more nearly equal then check the distances again. Both distances must be the same.

12. Remove the cap frame driver and reattach the X stop/limit encoder assembly housing cover.

Flats Limits

The left hand flag inside the encoder assembly housing is the flats limits "flag-set." This flag actually consists of 2 flags set next to each other. The flags are arranged so that a small part of the flag-set parameter is missing material and the rest consists of the fully extended material. During the movement of the sash frame within its accepted mechanical limits, the flag-set will be interrupting the photo cell. The flag-set is adjusted so that when the mechanical limits are approached, the photo cell will not be interrupted by the flag-set and the movement will be disabled. This will occur at each end of the axis movement.

NOTE: The function of this flag-set is just the opposite from the cap frame limit flag-set.

1. Remove any cap frames or other specialty frames that may be present at any of the 12 head locations.
2. Remove the covers from the X and the Y stop/limit encoder assembly housings.

CAUTION! Incorrect move values used in the following steps may cause movement into the mechanism limits of the machine.

3. At the left hand flag locations inside the encoder assembly housings for both the X and Y axes, loosen the set screws that secure the flats limit flags and close the flag gap slightly at both edges. Snug the set screws to maintain the changed positions.
4. Assuring you are at the proper center index, use the move feature in the operating program to move the sash frame to one of the 4 mechanical extremes (left, right, front, or rear) in reference to the dimensions outlined below:

Sash Frame Movement Dimensions

X axis dimension = 204mm both left and right from center index.
Y axis dimension = 143mm both forward and backward from center index.

5. At the encoder assembly associated with the position moved to in the previous step, loosen the set screw that secures the flats limit flag for stopping the movement at this position.
6. Slowly rotate the flag until the photo cell is just removed from the flag material. When the photo cell is no longer interrupted the associated LED will change states - If it was ON it will go OFF, it was OFF it will go ON.
7. When the flag is set to just where the LED changes states, tighten the set screw.
8. Repeat the previous four steps with the other 3 sash frame mechanical movement extremes. When the adjustments are completed, reinstall the X and the Y stop/limit encoder assembly housing covers.

Trimmer System

Although the trimmer system for the EMC 10/12 is assembled and thoroughly tested before the machine is shipped, there are a few things to be aware of to help prevent problems.

- Dirt, dust, and thread lint may build up and prevent the movable knife from actuating correctly. Keep the area clean and you shouldn't have a problem. If for some reason you find that the movable knife is out of adjustment a procedure for adjusting it is presented in this section.
- Thread birdnesting around the rotary hook, picker, and UTC sensor arm could cause the knife and/or picker, to become misadjusted.

Sequence of Trim Events

During the trim function, many events occur with a set timing sequence to enable the trimming action to be successful. The following steps provide you with a very general outline (and sometimes brief descriptions) of the major actions that take place during the trim function.

1. While embroidering a design, the trim function is initiated when the embroidery machine detects the design code for: a color change, a trim, a set number of consecutive jump stitches, or the end of design.
2. The embroidery heads will slow to about 80 stitches per minute, which is the speed range for the trimming action.
3. The picker engages with the current thread loop as it is being formed in the hook and bobbin area. This process is required to provide the correct length for restarting embroidering next time this thread color is used.
4. The movable knife comes forward to the ready state for trimming. During its forward movement, it separates the top thread from the thread that is looped around the hook. It is here where it "selects" the top thread and bobbin thread for trimming.
5. When the movable knife returns to the "home" position, the selected threads will be cut between the movable knife and the spring knife.
6. At approximately the same time the threads are being cut, the grabber reaches out from behind the needle area and "grabs" the cut top thread (called the tail), pulling it up and into the Velcro wiper strip.
7. After the thread is cut and the tail is grabbed, the beam moves a small distance away from the current location and back again to insure the tail has been completely removed from the embroidery material.
8. When the trim is complete the machine begins embroidering again automatically.

Trimmer Setup And Adjustments

"FACTORY SERVICE ADVISED"



CAUTION! If these adjustments are attempted without using the proper procedures and tools (and without proper training in some cases), machine components may be damaged and operation of the trimmers may become inconsistent.

Minimum tools needed: a small screwdriver, a medium screwdriver, 1.5mm, 2mm, and 2.5mm allen wrenches, 10mm and 3/4 inch open-end wrenches, a 0-200 inch/pound torque wrench, the Cam Timing Fixture (Melco part number 995312-01) and the Select Position Fixture (Melco part number 995372-01).

Figure 2-25 identifies those components that comprise the trimmer system: the spring knife, the movable knife, and the under thread presser. These components are covered by the front bed plate and the needle plate (see inset in Figure 2-25). Remove the screws holding these covers to gain access. You may test the trimmer adjustments without the covers in place, but all covers must be installed while embroidering.

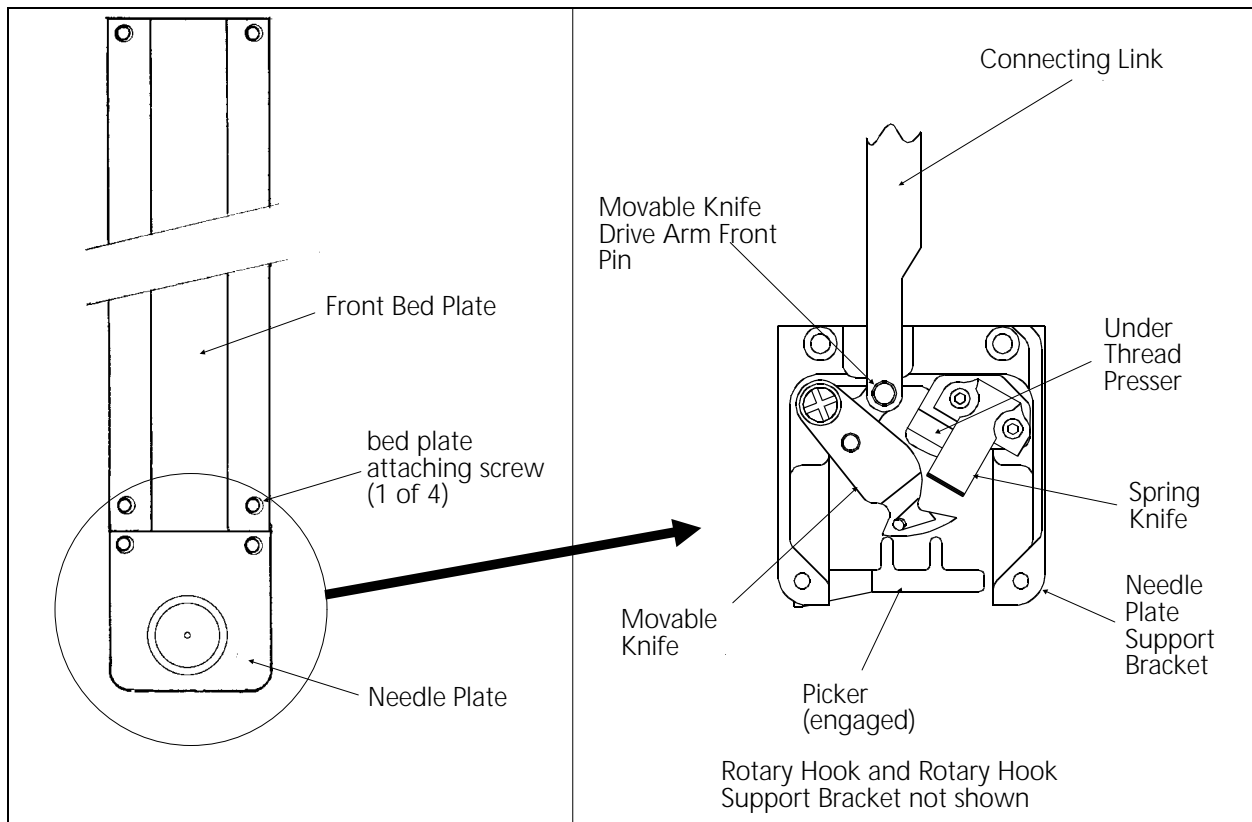

Figure 2 - 25 Trimmer Component ID

Spring Knife

Poor trimming quality and non trimming may be caused by the condition of the spring knife.

This situation may result if the spring knife is worn or is not parallel to the trimming action of the movable knife. Check this condition of the spring knife by inspecting the marks left on the surface of the movable knife that is under the spring knife. If the marks are more severe in the area that aligns with one edge of the spring knife, the spring knife may need replaced. Another way to check this condition is to perform the "ink wipeoff test" described below.

1. With the machine turned OFF, disconnect the connecting link from the movable knife drive arm by lifting it from the front pin (see Figure 2-25).
2. Pull the movable knife forward with a small hex wrench hooked behind it.
3. With a black marking pen mark the areas of the movable knife as shown in the left illustration of Figure 2-26.

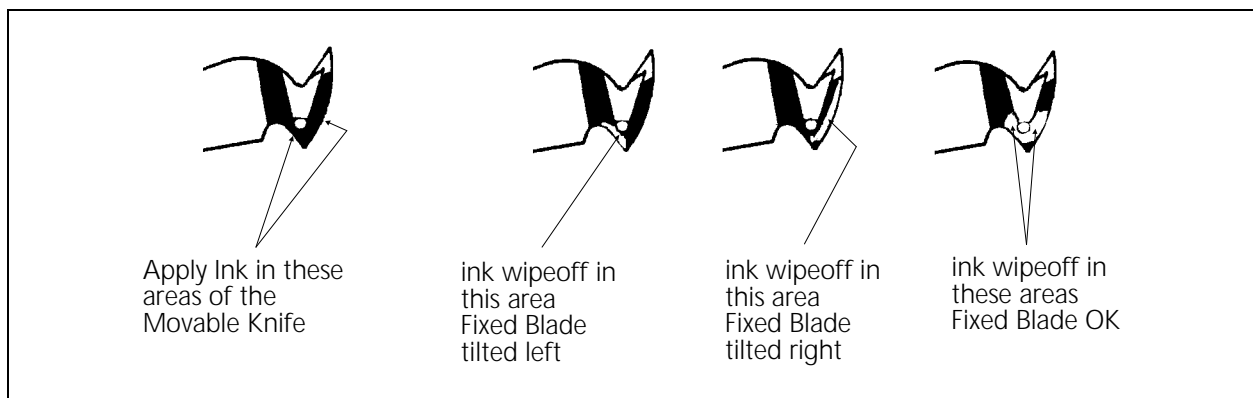

Figure 2 - 26 Ink Wipeoff Test

4. Push the movable knife back under the spring knife to simulate the thread cutting action.
5. Again pull the knife forward and inspect where the marking pen ink has been wiped off. Refer to the remaining three illustrations in Figure 2-26 to determine if the spring knife has a problem.

Note: The spring knife has no adjustment. You should make no attempt to bend or reshape the spring knife in any way.

The general condition of sharpness of the blade will also affect trimming quality. It may be that the spring knife has simply become dull and needs replaced.

You may check the thread cutting ability in much the same way as the ink wipeoff test by performing actual thread cuts at several locations across the cutting range of the blade. To do this follow the steps below:

1. With the machine turned OFF, disconnect the connecting link from the movable knife drive arm by lifting it from the front pin (see Figure 2-25).
2. Pull the movable knife forward with a small hex wrench hooked behind it.
3. Obtain a piece of upper thread from the tensioner assembly and drape it over the movable knife. (See Figure 2-27.)

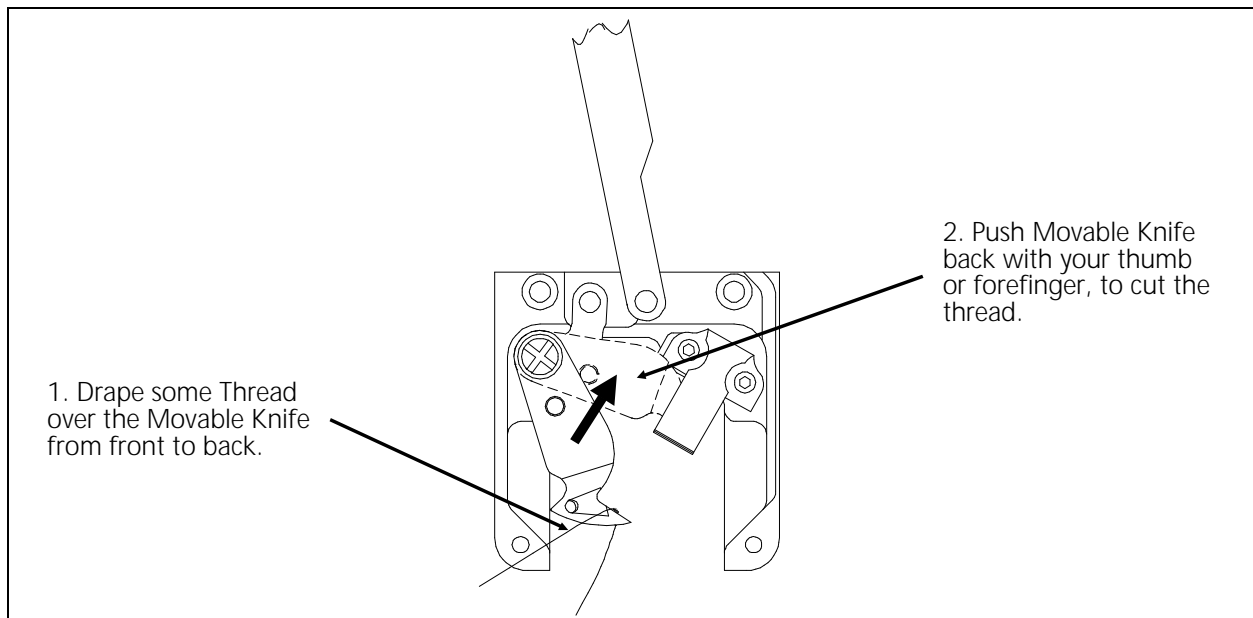

Figure 2 - 27 Checking The Cut

4. With the thread draped over the movable knife from back to front, gently hold the thread so there is some slack and then push the knife back until the thread is cut. This cut should be clean, and should not be frayed.
5. Repeat Step 4 with the thread positioned at different locations across cutting surface.
6. If the thread is frayed at any location you may need to replace the spring knife, movable knife, or both.

Replace the spring knife per the instructions in Section 3 of this manual. Do not attempt to make any adjustment to the spring knife, however, after replacing a spring knife and all the covers and needle plate, it is advised to operate the TRIM command several times to allow the spring knife to 'seat' itself with the movable knife.

Under Thread Presser

The under thread presser, shown in Figure 2-28, holds the bobbin thread after a trim. This permits a loop of bobbin thread for the next stitch. While the under thread presser holds the bobbin thread there should only be enough pressure applied to hold the thread in place under the movable knife.

If the under thread presser is damaged it may cause problems that look like tension troubles. For example, if the pressure of the under thread presser against the movable knife is too much, it may hold the bobbin thread and not allow a loop to be formed, or it may nick or fray the thread, making it look like the bobbin tension is incorrect.

Another example, is if the under thread presser is "crumpled" (see Figure 2-28), it does not allow the movable knife to pass under the spring knife completely to cut the thread, causing a "no cut" condition. If the under thread presser is damaged it may cause intermittent long tails of the upper thread.

Checking the under thread presser is done in two parts. First by looking at the part itself to see if there has been any "crumpling" as shown in the bottom left section of Figure 2-28. Crumpling is damage caused by the movable knife hitting the under thread presser. If you see visual evidence of any damage, replace the under thread presser as described in Section 3 of this manual.

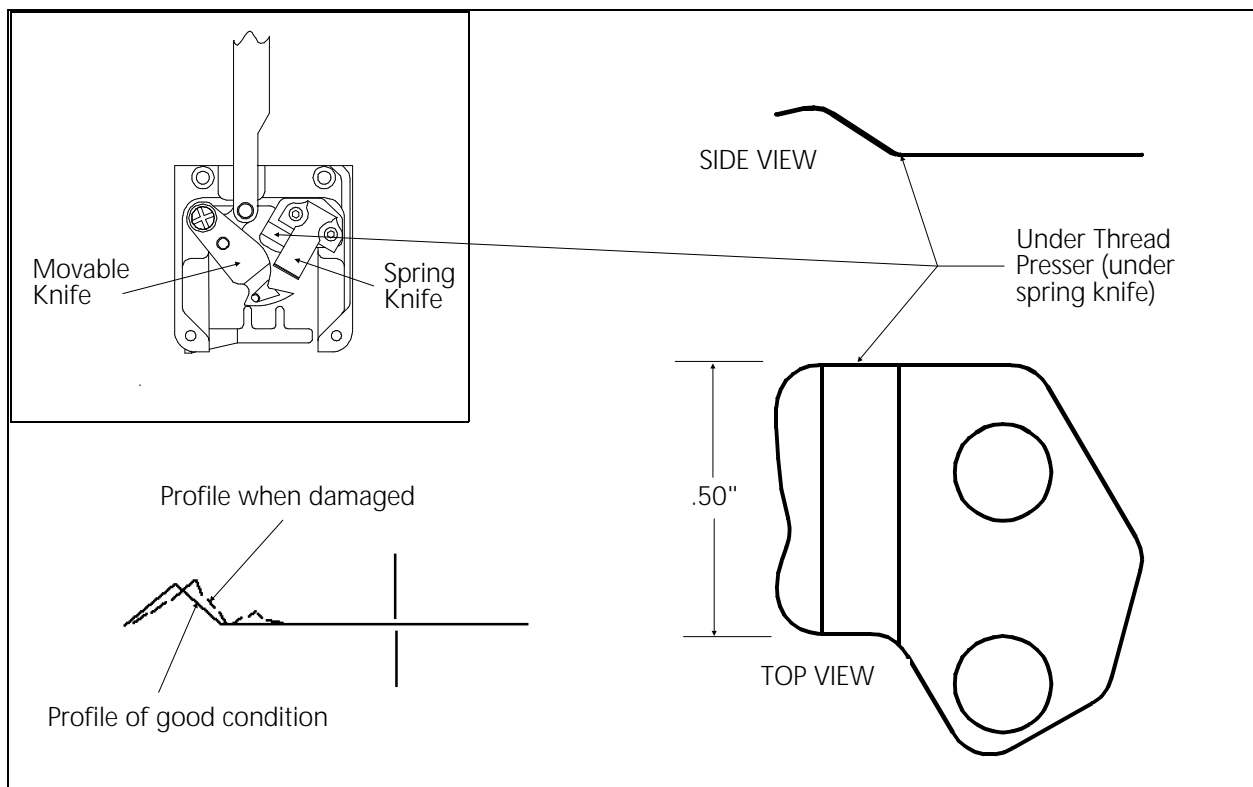

Figure 2 - 28 Under Thread Presser

The second part of checking under thread presser is to check if the bobbin thread is in fact being held in place.

1. While the machine is still turned OFF, remove the front bed cover and disconnect the connecting link from the movable knife drive arm by lifting it from the front pin (see Figure 2-25.)
2. Pull the movable knife forward with a small hex wrench hooked behind it.
3. Leaving the bobbin case in the rotary hook, pull off some bobbin thread and drape it over the movable knife. (See Figure 2-27.)
4. With the thread draped over the movable knife from back to front, gently hold the thread so there is some slack and then push the knife back until the thread is cut. This cut should be clean, and should not be frayed.

If the thread is frayed you may need to replace the spring knife, movable knife, or both. To replace either of these parts, refer to the procedures in Section 3 of this manual.

5. The "top" thread should be loose and fall away, because it has no support. The "bottom" thread should be held in place under the movable knife by the under thread presser.
6. If the under thread presser does not provide the required action, replace it and check using steps 2 to 4 again.
7. After you are satisfied with the under thread presser action, re-attach the connecting link and front bed plate (see Figure 2-25).

Movable Knife Adjustment

Each movable knife is connected to the camming mechanism via a series of levers, rods and pivots. During a trim operation the cam follower is engaged and this in turn activates the trimmer reciprocator arm which provides back and forth movement to the trimmer rod (refer to Figure 2-30). The trimmer rod is connected to the short and long trimmer linkages that transmit movement to the connecting link, causing the movable knife to "cut."

Movable Knife Home Position

To check the movable knives for possible need for home position adjustment, perform the following steps:

1. Remove the needle plates from all twelve embroidery heads (refer to Figure 2-25). Visually inspect the trimmer mechanisms. Replace any crumpled under thread pressers or damaged spring knives. Lubricate the trimmer knife drive arm (refer to the EMC 10/12 Operation Manual).
2. Turn the machine power ON.
3. From the Control Panel click the Advanced button and select Trim in the Do Now section of the Advanced Features dialog box.
4. Visually check all movable knives. The knives should be located under the spring knife, positioned as shown in Figure 2-29. If the sloped rear tip of the movable knife is not showing in front of the leading edge of the spring knife, the "home" position needs to be adjusted. DO NOT Adjust if the knife position looks like Figure 2-29.

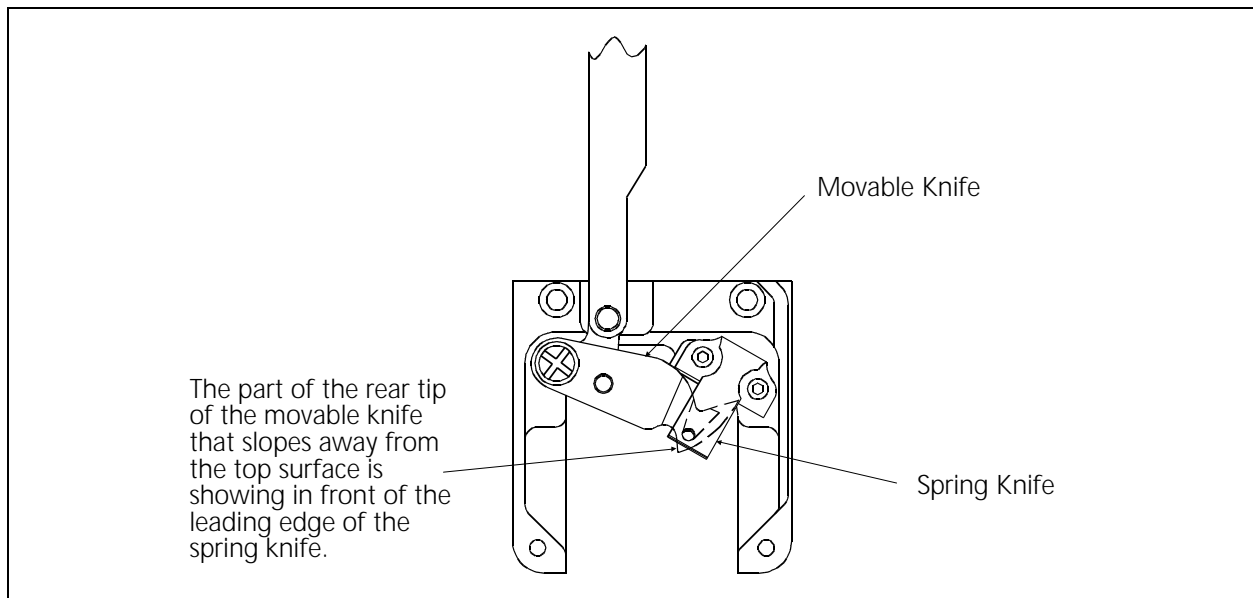

Figure 2 - 29 Movable Knife Home Position

5. If all 12 knives are in the same relative position, but not in the home position, adjust all knife positions simultaneously as described in Steps 6 and 7.
6. Refer to Figure 2-30 and loosen the set screws at point A.

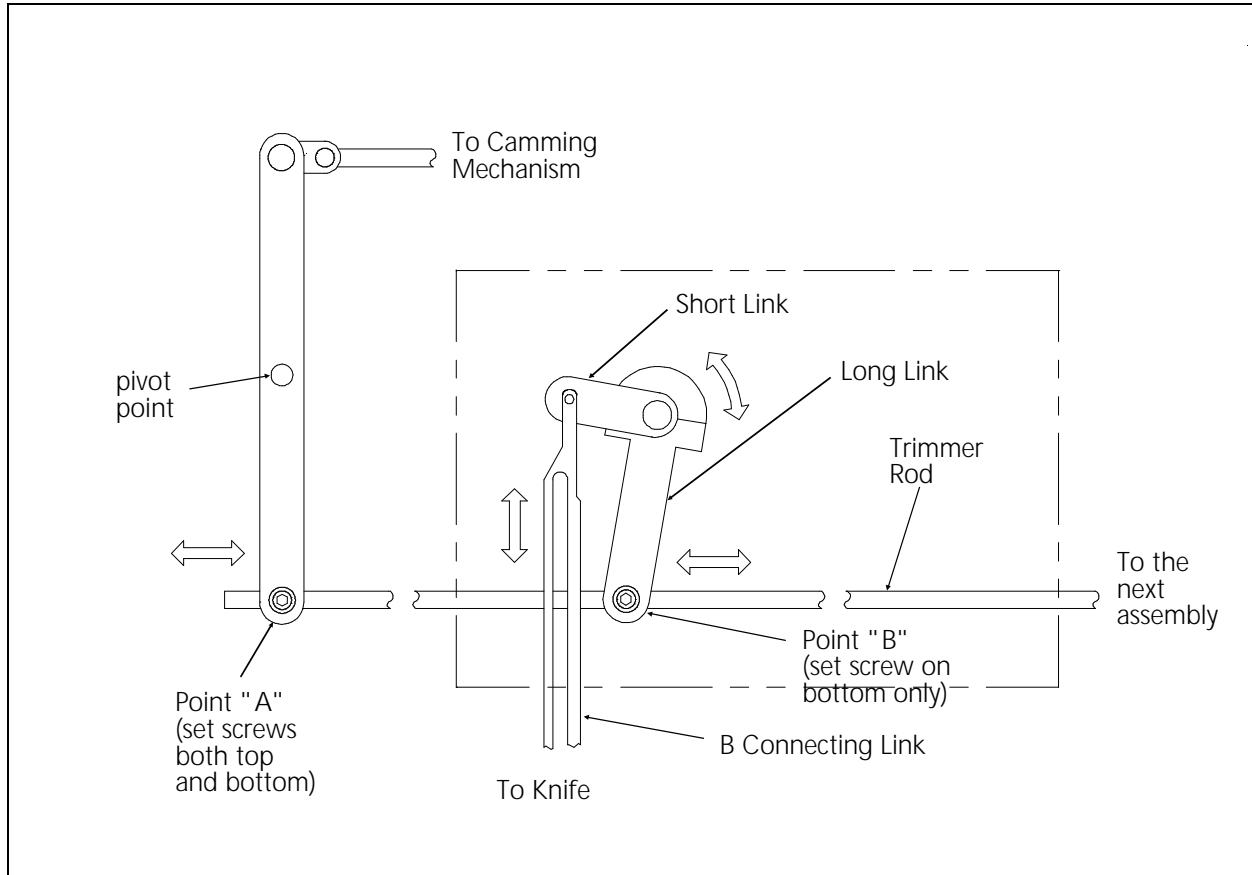

Figure 2 - 30

7. Move the trimmer rod until all the knives are at the home position as shown in Figure 2-29, then tighten the set screws at point A.
8. If after the majority of knives are at the home position but some individual knives are not in the home position, refer to the following steps:

WARNING! Turn the machine power OFF.

9. Disconnect the front portion of the sash frame and lower the table (refer to the EMC 10/12 Operation Manual).
10. Remove the cam belt cover and cam box cover. Visually inspect the toothed timing belt and associated pulleys. If the timing belt or pulleys are worn or damaged they should be replaced before continuing with this procedure.



11. Turn the power ON. In the Control Panel window, click the Advanced button, then click the Service button in the resultant Advanced Features dialog box.

Trimmer Cam Position



12. In the Service dialog box click the Cutter Timing button. This takes the Z rotation to the position for setting the trimmer cam. Record the degrees number indicated in the Z Posn section of the Service dialog at this time. This number is referred to in Step 21.

13. Place the test fixture #995312-01 onto the trimmer cam box (refer to Figure 2-31).

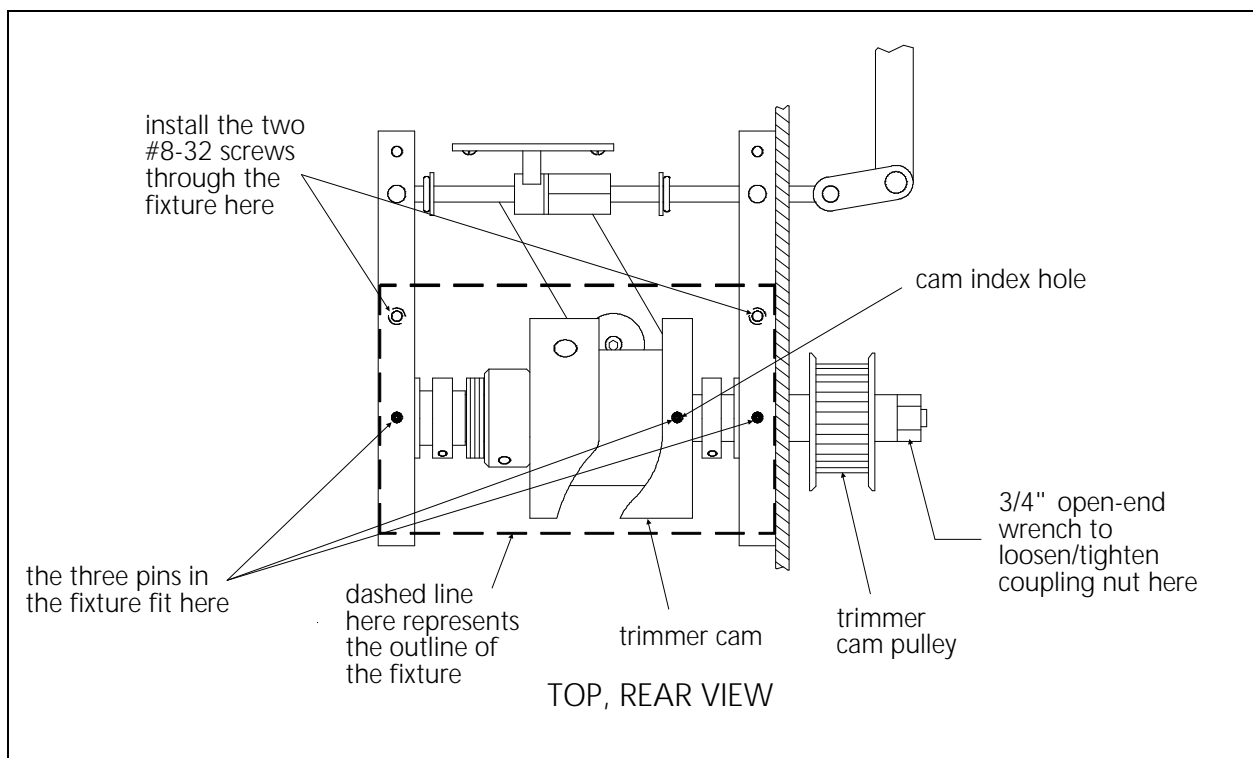

Figure 2 - 31 Trimmer Cam Box

14. If the three pins in the fixture drop into the holes as indicated in Figure 2-31, you have correct trimmer cam positioning and can skip to Step 27.
15. If the pins in the fixture do not align you must adjust the trimmer cam rotational position.
16. In the Service dialog, click the Release check box to enable manual rotation of the Z-axis shaft.



17. Rotate the Z-axis shaft by hand at the trimmer cam pulley until all three of the pins in the fixture drop into the holes as indicated in Figure 2-31. The middle pin must be securely in positioned in the cam index hole.

18. Using two #8-32 UNC X 1/2" screws, attach the test fixture onto the trimmer cam box at the locations shown in Figure 2-31.

19. While the the test fixture holds the cam shaft in place, loosen the lower trimmer cam pulley by loosening the coupling nut with a 3/4 inch open-end wrench as shown in Figure 2-31.



20. Refer to the Z Posn degrees number currently indicated in the Service dialog box.

21. Rotate the Z-axis shaft with a 4M hex wrench until the Z Posn indication is the same as the degrees number you recorded in Step 12.

22. While maintaining the degrees at that number, click the Release check box to lock the Z shaft movement.

23. Using a torque wrench, tighten the coupling nut that holds the cam pulley to the shaft. Tighten the nut to a torque of 175 in/lbs.



24. Remove the two #8-32 screws and the test fixture from the cam box.

25. From the Service dialog box click the Cutter Timing button one or two times.

26. Again place the test fixture #995312-01 onto the trimmer cam box (refer to Figure 2-31) to check for proper trimmer cam positioning.

- If the three pins in the fixture drop into the holes as indicated in Figure 2-31, you have correct trimmer cam positioning and may continue with this procedure.
- If the pins in the fixture do not align you must readjust the trimmer cam as previously outlined in this procedure, starting with Step 16.



27. Remove the test fixture from the trimmer cam box and store it.

28. Select Trim in the Do Now section of the Advanced Features dialog box.

29. Visually check all movable knives. The knives should be located under the spring knife, positioned as shown in Figure 2-29. If not repeat Steps 6 and 7 before continuing.

Select Position



30. Engage the cam follower into the cam groove (refer to Figure 2-31) and hold the follower in place with a small block of wood (or other similar jamming device).

31. In the Service dialog, click the Release check box to enable manual rotation of the Z-axis shaft.



32. Rotate the Z-axis shaft by hand to a Z Posn indication of 312 degrees. While maintaining the 312 degree position, click the Release check box to remove the check and lock the Z shaft movement.

33. Install the needle plate back onto head #12.

34. Using Select Position Fixture (Melco part number 995372-01), check the movable knife for the select position (refer to Figure 2-32).

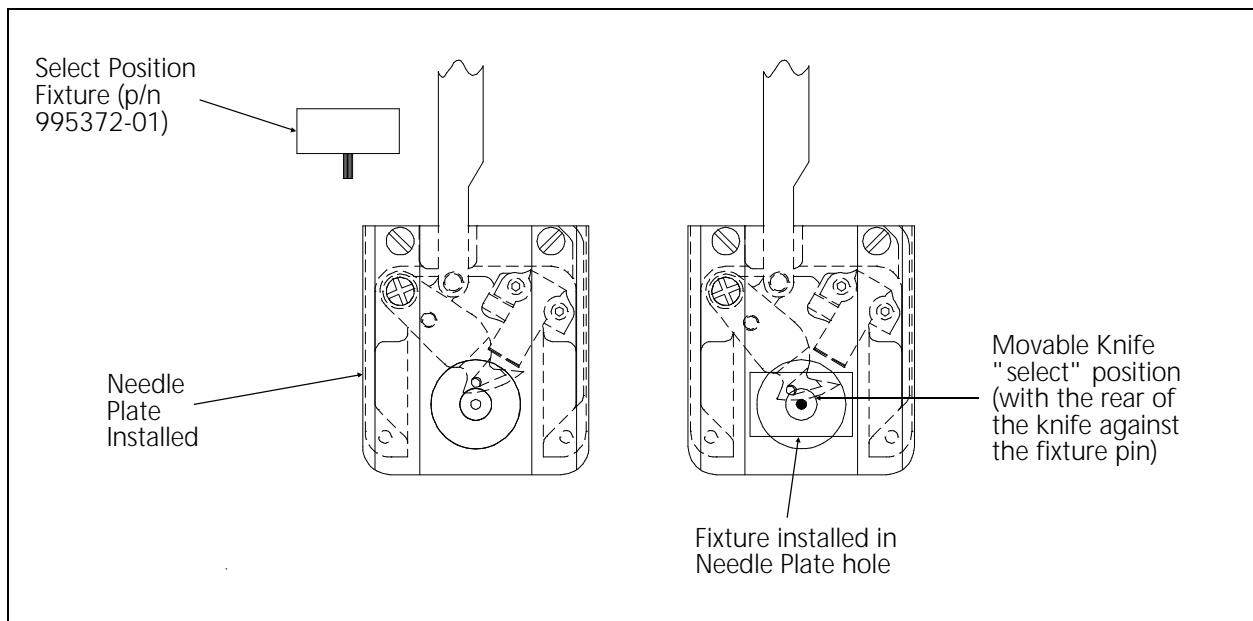

Figure 2 - 32

35. If the movable knife select position is correct, remove the select position fixture and proceed to the next head.

36. If the select position is not correct, loosen the long link at point "B" (referring to Figure 2-30).



37. Move the long link back and forth until the correct select position is achieved. Tighten the long link at point "B", then remove the select position fixture and proceed to the next head.

38. Adjust all twelve movable knives to the same relative select position.
39. Remove the select position fixture from the last head and then remove the jamming device from the cam follower.



40. Click the Trim button several times in the Do Now section of the Advanced Features dialog box.
41. Inspect all 12 knives to insure they are at the home position. The rear point of the movable knife should just protrude from under the spring knife (refer to Figure 2-29).
42. Move the spring knife of any home position that may need adjustment.

Note: If moving the spring knife does not correct the adjustment, you may need to yield equally on both the select and home position adjustments for those knives that do not position correctly at both locations.

43. Install all the needle plates.
44. Replace the cam belt cover and cam box cover.
45. If embroidering on flats, raise the table and reconnect the front sash frame.



Picker Finger Center Position

If the cap frame option is not part of your system, you may refer to the following procedure to center the picker fingers, should it become necessary.

If your EMC 10/12 has the cap frame option, you must give centering priority to the cap frame driver. When the cap frame driver is centered properly, the picker fingers will automatically come into proper center alignment. This is because the dovetail clamp for the cap frame driver is fixed to the same bracket as the picker fingers.

1. Loosen the two picker/dovetail bracket screws on the cylinder arm (see Figure 2-33).
 - 2a. Move the bracket left or right until the picker fingers are centered on the needle shaft.

OR

 - 2b. With both trimmers and cap frame options on the machine, move the bracket to center the installed cap frame driver on the embroidery head arm.
3. Retighten the screws.

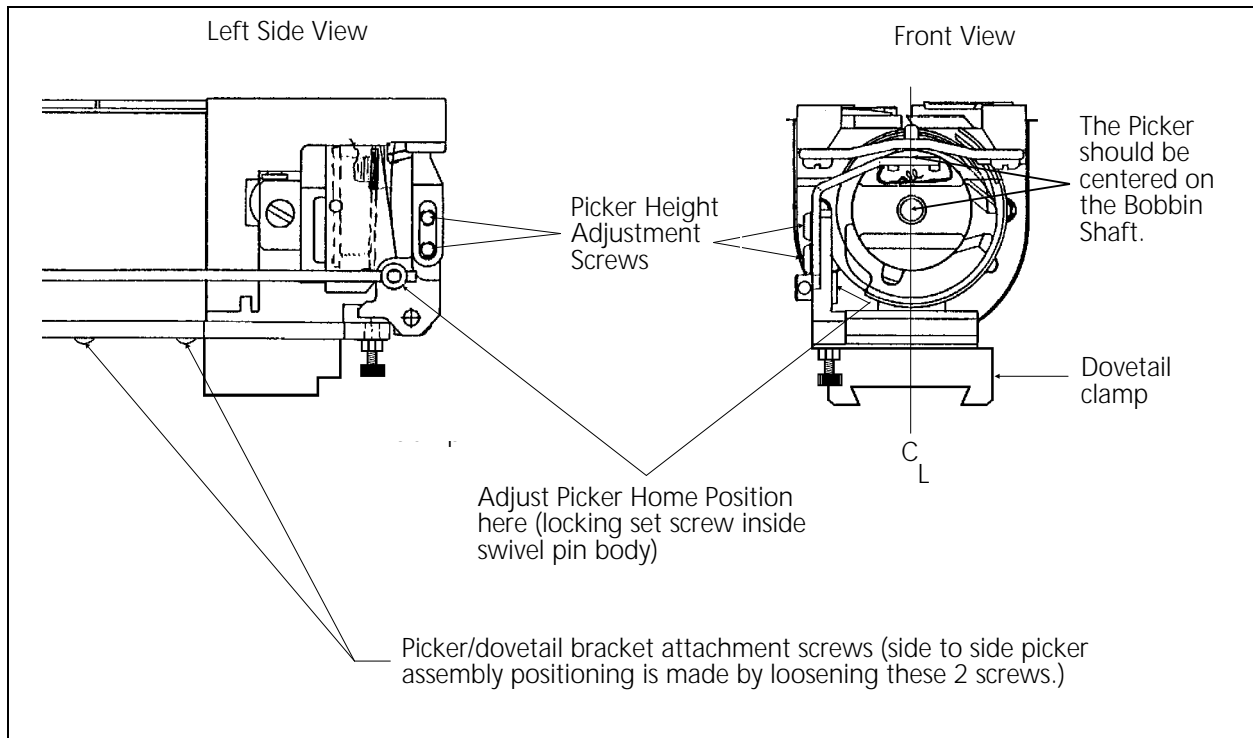

Figure 2 - 33

Picker Home Position

Note: This procedure requires the use of a special service tool: the Melco picker set fixture (p/n 995339-01).

1. Install the picker set fixture (as shown in Figure 2-34) to set the picker home position.
2. Loosen the set screw inside the swivel pin body shown in Figure 2-33.
3. Move the picker until it rests in the fixture at the picker home position as shown in Figure 2-34.
4. Retighten the set screw.

Picker Height/Depth Position

Note: This procedure requires the use of a special service tool: the Melco picker set fixture (p/n 995339-01).

1. To adjust the picker height/depth position, manually push the picker into place as shown in Figure 2-34.
2. Loosen the 2 screws on the left side of the picker as shown in Figure 2-33.
3. Position the height of the picker against the fixture location shown in Figure 2-34.

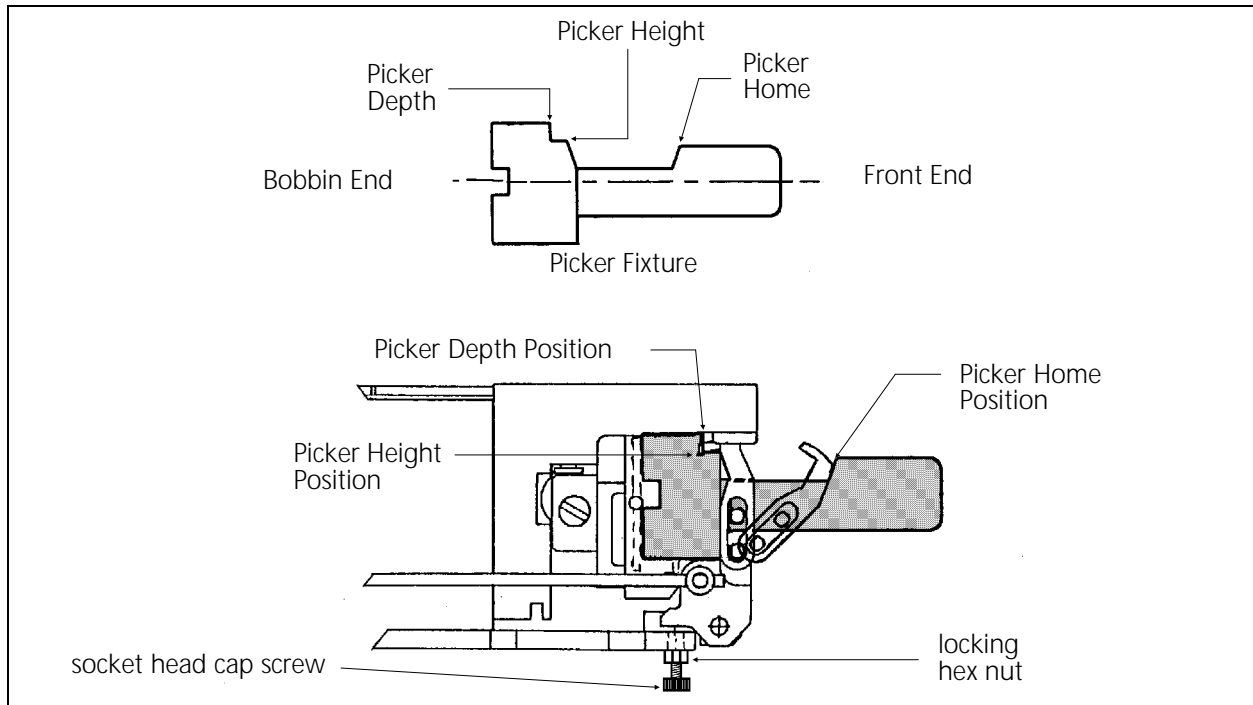

Figure 2 - 34

4. Retighten the 2 screws.
5. Loosen the hex nut which is locking the socket head cap screw under the picker base as shown in Figure 2-34.
6. While still holding the picker in the height/depth position, rotate the socket head cap screw until the depth position is attained as shown in Figure 2-34.
7. Retighten the hex nut, locking the socket head cap screw to hold the depth position setting.

Grabber Setup And Adjustments

1. The grabber blade must pass through the center of the wiper (two pieces of Velcro mounted in a metal bracket). Adjustment is accomplished by loosening the screw on the front of the grabber mount and positioning the blade to pass through the center of the wiper.
2. When the grabber blade is fully retracted, the hook portion of the tip should remain about .060 to .090 inches (1 1/2 to 2 1/2mm) from the grabber blade guide as shown in Figure 2-35.

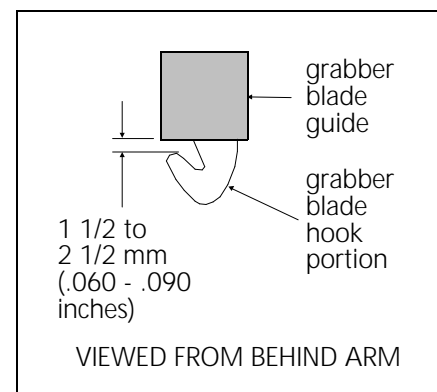

Figure 2 - 35

3. Confirm that all 12 grabber blades are at the recommended distance from the guide.
4. If any blades are not at the recommended distance, loosen the set screw and push the grabber blade back and forth until the correct distance has been achieved (refer to Figure 2-36 for location of the set screw).

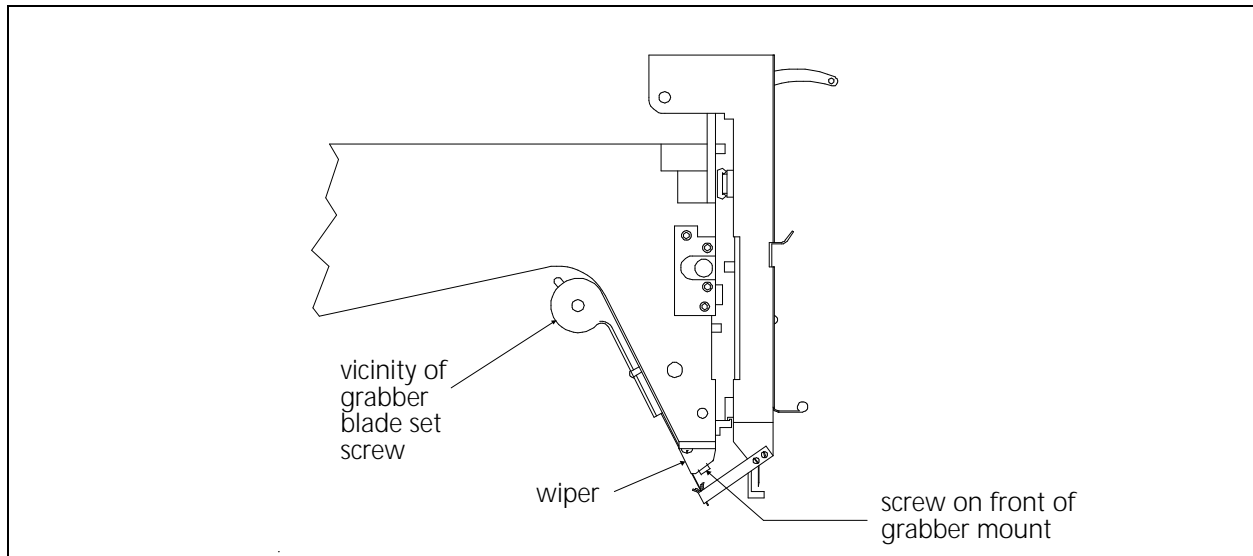

Figure 2 - 36 Grabber Setup

5. Tighten the set screw.
6. Go to the Thread Grabber menu and select Full Extended. If any blades are not centered in the wiper, loosen the set screw and push the grabber blade side to side until the correct centering alignment has been achieved (refer to Figure 2-36 for location of the set screw). Use care not to reposition the grabber blade hook gap that was set in Step 4.



7. Go to the Thread Grabber menu and select Start Test.
8. If the adjustment seems correct, select Stop Test.

Under Thread Control (UTC) Adjustments

It is very important that you follow these instructions any time the rotary hook retaining finger or UTC is loosened or moved. Please follow the instructions in the order they occur.

Note: The procedures in this section require the following special tools:
 1) a small straight blade screw driver with a thin blade, and
 2) the Melco UTC combination gauge part number 009027-01.

Rotary Hook Retaining Finger Positioning

1. Attach the UTC assembly as described earlier in this procedure.
2. Turn the machine ON and go to the Head Timing menu.
3. Position the head to the "Needle Depth" location in the Head Timing menu.
4. Slightly loosen the 2 UTC assembly mounting screws from under the needle plate support bracket.
5. Place the finger of the UTC combination gauge (see Figure 2-38 for diagram of the gauge) between the retaining finger tab and the rotary hook inner basket notch (see Figure 2-37).

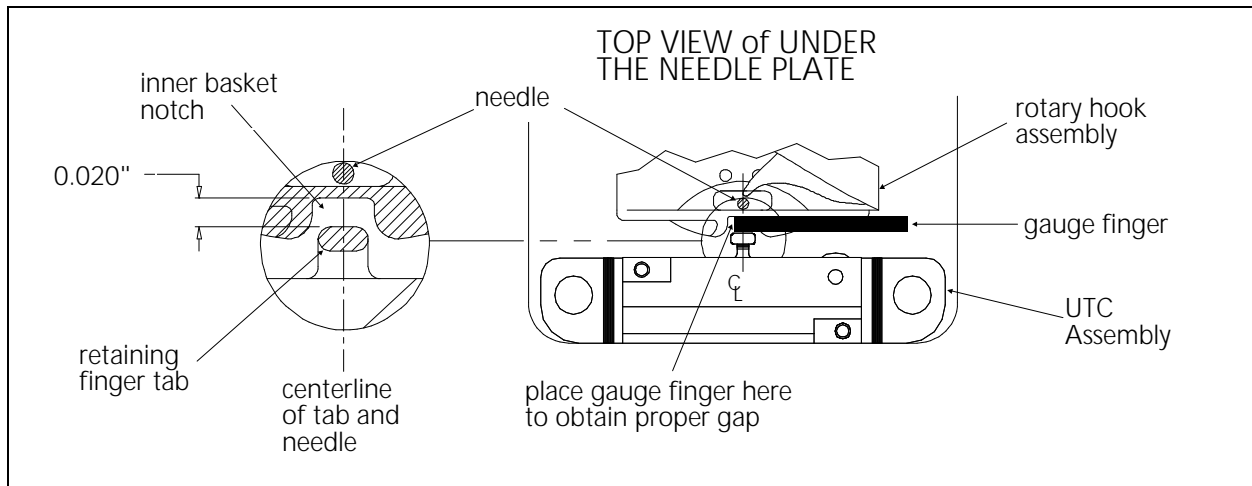

Figure 2 - 37

6. Position the UTC assembly until the gap between the retaining finger tab and the rotary hook inner basket notch is set to the thickness of the gauge finger. The gap is 0.020 inches as shown in Figure 2-37).
7. Additionally, align the center of the retaining finger tab to the center of the needle as indicated in Figure 2-37.
8. Tighten the UTC assembly mounting screws.
9. Place the UTC Combination Gauge on top of the needle plate support bracket as shown in Figure 2-38 and check that the UTC detection arm does not touch the bottom surface of the gauge which represents the bottom of the needle plate when it is installed.
10. If the arm touches the gauge, carefully reshape the arm slightly until it clears.

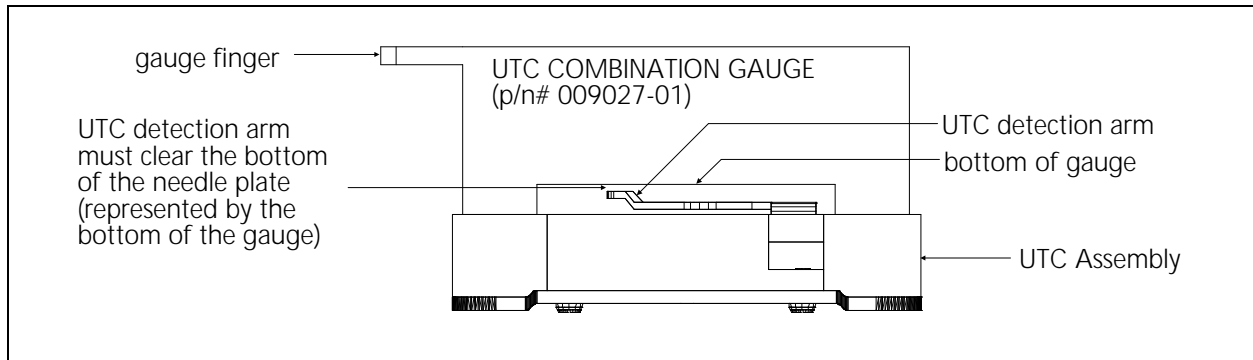

Figure 2 - 38

11. Refer to Figure 2-39 and lift the connecting link off of the movable knife assembly.

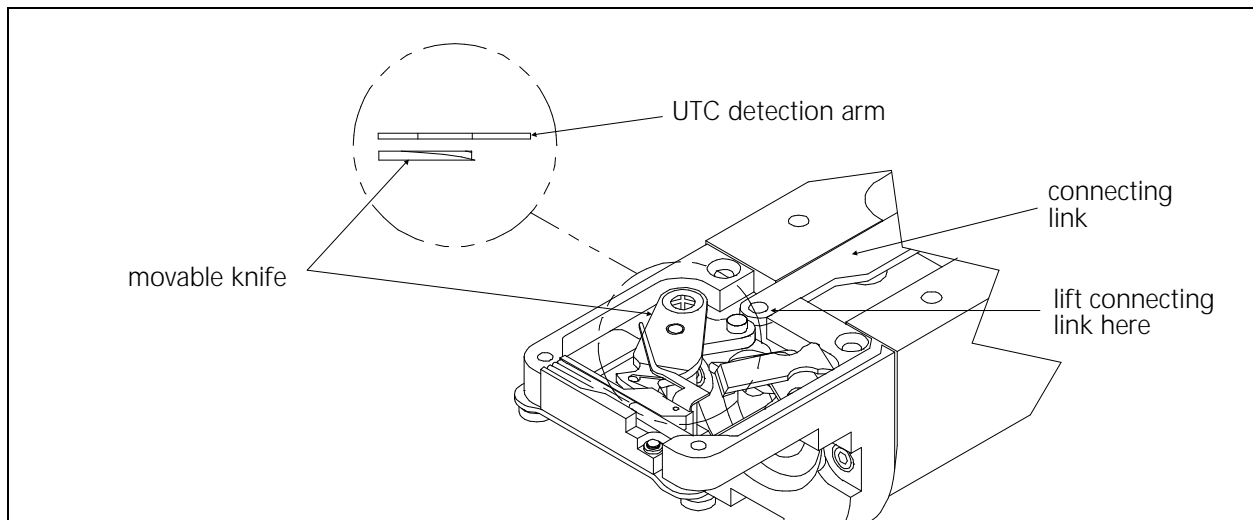

Figure 2 - 39

12. Check that the movable knife clears the UTC detection arm by physically moving the knife under the UTC detection arm and back.
13. If the knife touches the arm, reshape the arm slightly until it clears then repeat steps 9 through 12.
14. Re-attach the connecting link to the pin on the movable knife assembly.

Caution! When installing the covers, be sure not to pinch the UTC Assembly wires!

15. Re-attach the right side rotary hook cover, the needle plate, and the front bed cover.

Sew Test

We now must actually embroider onto properly hooped material to prove the adjustment is proper. A special design named UTCTEST comes on a disk with your machine. Load the design into your EDS software or optional disk drive and send it to the sewing peripheral.

The primary purpose of the UTC is to signal when the bobbin thread runs out or breaks. The UTC has a mechanical arm that is bumped by the bobbin thread during every stitch. When the sensor is not bumped for the number of consecutive stitches that are set as "Bobbin Count," the machine stops, backs up, and beeps.

If the UTC is too close to the needle, it may not react reliably in detecting the absence of bobbin thread. If the UTC is too far away from the needle, it may falsely indicate that the machine is out of bobbin thread when it indeed has bobbin thread.

Additionally, if the bobbin tension is set too loose, it may also falsely indicate that the machine is out of bobbin thread when it has bobbin thread.

Preliminary Checks

The following must be checked before performing the embroidering:

1. Check that the bobbin tension is within the proper adjustment specifications as described in the operation manual.
2. Verify that the BOB. COUNT in the BOBBIN MENU is set to 5.

Perform The Test

During the embroidering:

- A) Check that the UTC detects an absence of bobbin thread when you run out of bobbin thread and displays the CHECK BOBBIN message.
 1. Test for this by wrapping a foot or so of thread around an empty bobbin.
 2. Embroider the test design until the thread is completely used.
 3. Repeat steps 1 and 2 until the bobbin runs out at least once in both directions of diagonal stitching in the test design.
 4. If the sensor does not detect when the bobbin runs out of thread, slightly loosen the UTC sensor body at the screws shown in Figure 2-40, and at the slotted screw hole (left side) move the sensor a very small amount away from the needle. Re-tighten the screws.

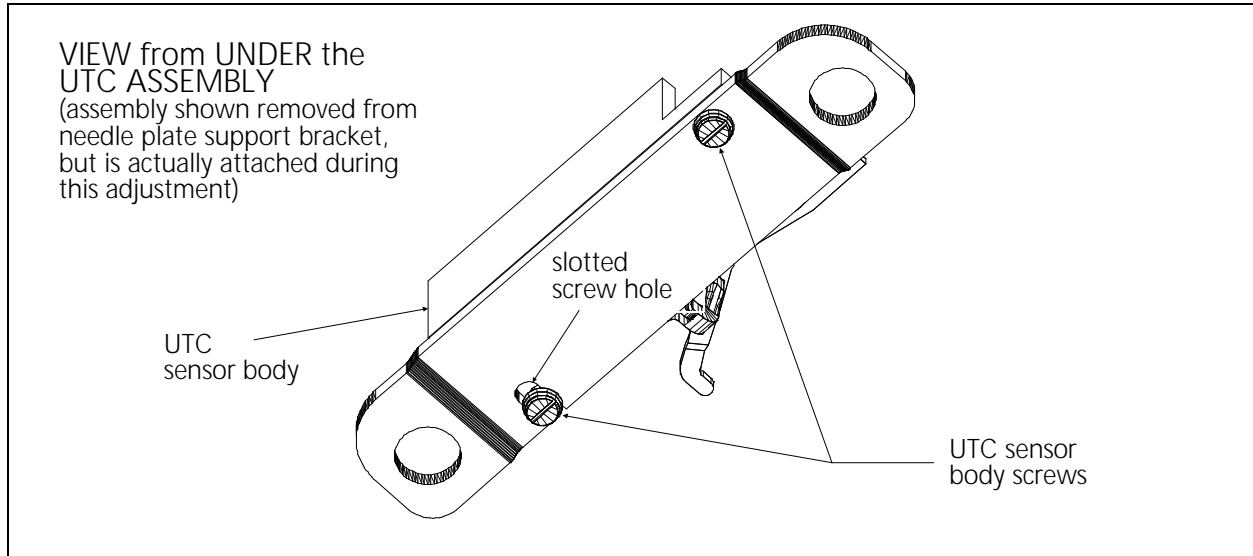

Figure 2 - 40

- B) Check that the UTC does not falsely signal the CHECK BOBBIN message when thread is still on the bobbin.
1. Test for this by simply sewing with the test design. For reliable results, embroider the design for at least 5 minutes, or about 4000 stitches at 750 stitches per minute.
 2. If you get false CHECK BOBBIN messages, slightly loosen the UTC sensor body at the screws shown in Figure 2-40, and at the slotted screw hole (left side) move the sensor a very small amount closer to the needle. Re-tighten the screws.

This page intentionally left blank

3. Mechanical Disassembly

General

This section of the manual provides detailed information for performing parts replacement that may be required during the life of the product. These procedures are guidelines for reference by personnel practicing good maintenance and repair techniques.

With certain areas of this section it is recommended that the procedures be performed by a factory-trained technician. This reference is indicated by stating "FACTORY SERVICE ADVISED" at the start of the procedure.



WARNING! Failure to practice good maintenance and repair techniques may result in injury to personnel performing the work and cause damage to the equipment!

Note: The system warranty is exclusive of, and MAY BE VOID, if poor maintenance practices cause damage to the equipment.

EMC 10/12 User Station

The user station section in this manual contains disassembly procedures for such items as removing covers and printed circuit boards, to changing various system switches and the light bulbs in the lighting system.

Logic Control Box

The logic control box is the heart of the EMC 10/12 control system. The computer motherboard, the low voltage driver PCB for the machine, and much of the embroidery machine control electronics (several upright PCBs) are located inside the logic control box (see Figure 3-1). The logic control box is located at the rear of the user station area on the right side of the EMC 10/12.

Removing Logic Control Box Covers

1. Turn OFF the power switch to the EMC 10/12 and remove the power cord from the power source electrical outlet.
2. Remove the screws that secure the logic control box outer cover and carefully lift the cover off the top of the box. Remove the screws that secure the inner cover and remove the inner cover.
3. Attach a static control strap from yourself to a non-painted portion of the logic control box frame before performing any service inside the box.

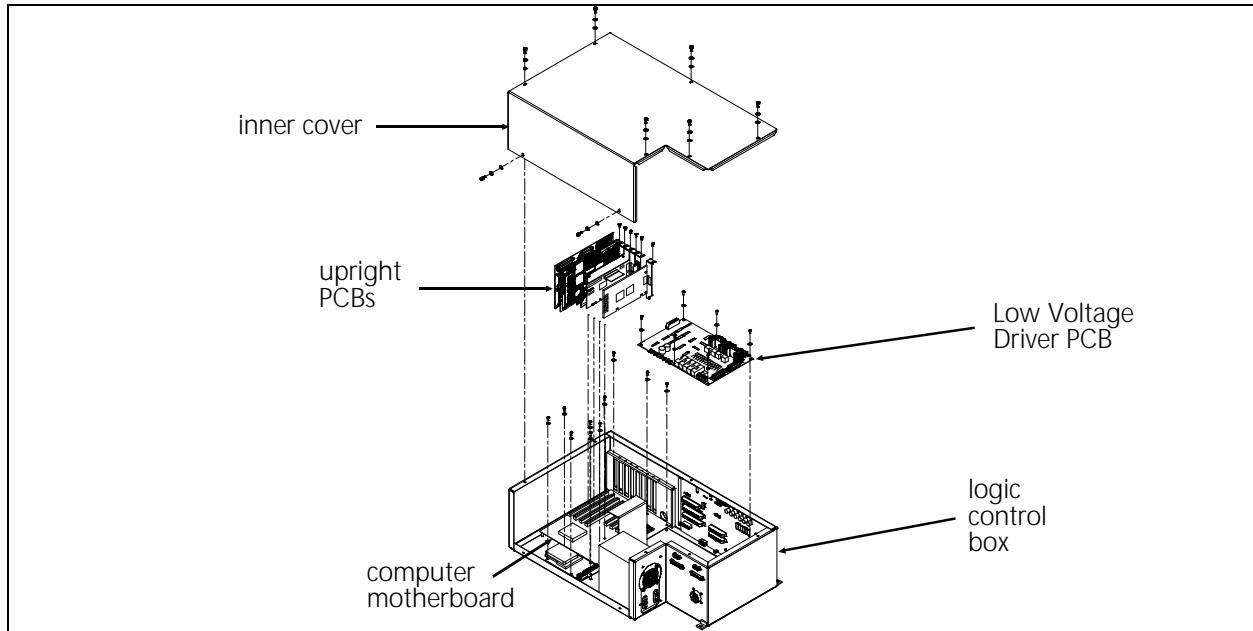

Figure 3 - 1

Replacing Upright PCBs



CAUTION! Failure to use a properly installed static grounding strap may cause damage to the electronics in the EMC 10/12.

The components inside the logic control box are quite sensitive to static electricity, and severe damage may be caused if proper procedures are not followed, such as using the static grounding strap. It is highly recommended that work inside the logic control box be conducted by personnel practicing proper static control methods.

Inside the logic control box are five printed circuit boards plugged upright into the computer motherboard. The five PCBs are: the Control Interface, the Machine CPU, the Video Controller, the Disk Drive Controller, and the Ethernet network PCB. Refer to Figure 3-2 to identify the specific location of each PCB.

To replace any of the PCBs plugged into the computer motherboard, refer to the figure on the previous page and following steps:

1. Check that the power switch to the EMC 10/12 is OFF and the power cord is removed from the power source electrical outlet.
2. Remove the logic control box inner and outer covers as previously described.
3. Install a static grounding strap between the EMC 10/12 and the personnel performing this procedure.

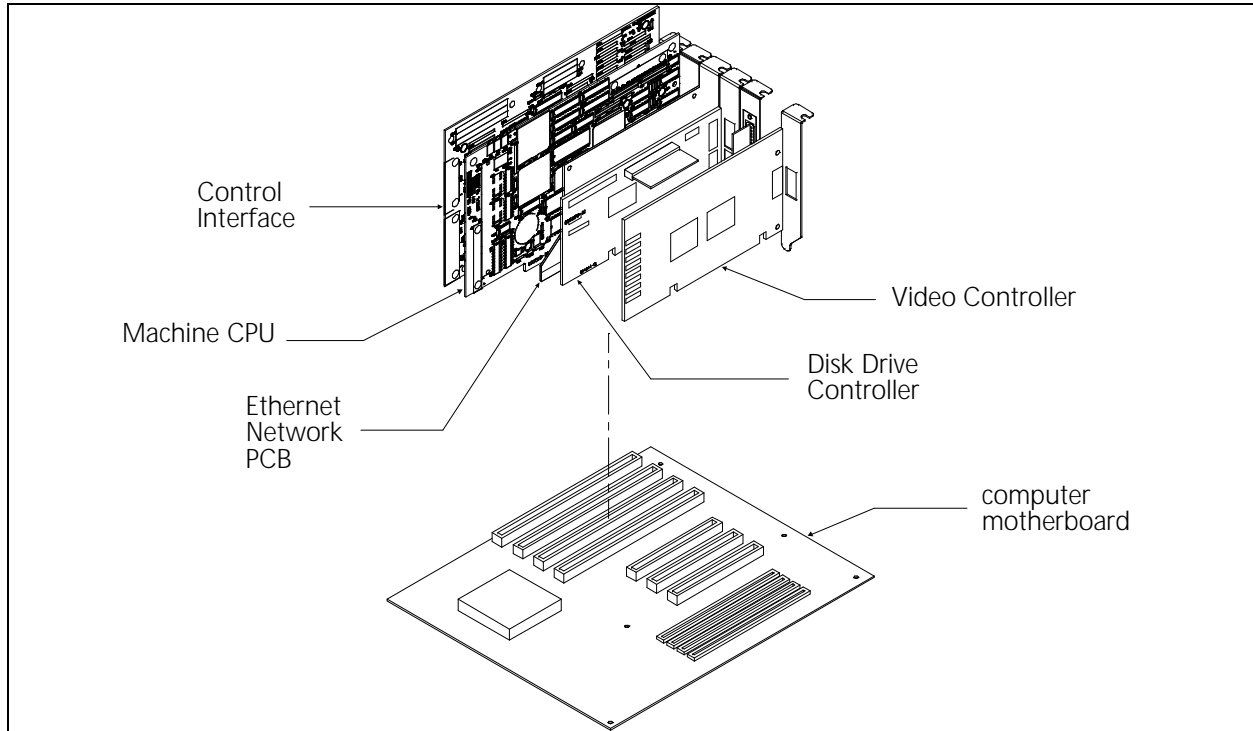

Figure 3 - 2

4. Mark the location for reinstallation later, and then remove any and all cables that may be attached to the printed circuit board assembly you are removing.
5. Remove the screw securing the specific PCB end bracket to the PCB bracket support frame (refer to Figure 3-1).
6. Grasp the PCB at the top outside corners and carefully pull up on the PCB to remove it from the computer motherboard edge connector where it is installed. (Use a gentle rocking motion to make it slightly easier to release the board from the connector.)



CAUTION! Once the printed circuit board is removed, use extreme care in handling it. Portions of the board may be very sensitive to static charges. Any further handling of the PCB must be done with the continued use of the static grounding strap until reinstalled.

To install the PCB assembly, position the board edge connector over the edge connector in the computer motherboard and lower the PCB into the connector, then reverse the order of the other steps used to remove the assembly.

Replacing The Computer Motherboard

1. Turn OFF the power switch to the EMC 10/12 and remove the power cord from the power source electrical outlet.
2. Remove the logic control box inner and outer covers as previously described.

3. Install a static grounding strap between the EMC 10/12 and the personnel performing this procedure.
4. Remove all the upright PCBs that reside in the computer motherboard connectors (see the section entitled Replacing Upright PCBs).
5. Remove the various cables and harnesses from the other connectors of the computer motherboard.
6. Remove the six (6) screws that secure the motherboard to the base of the logic control box (see Figure 3-3).

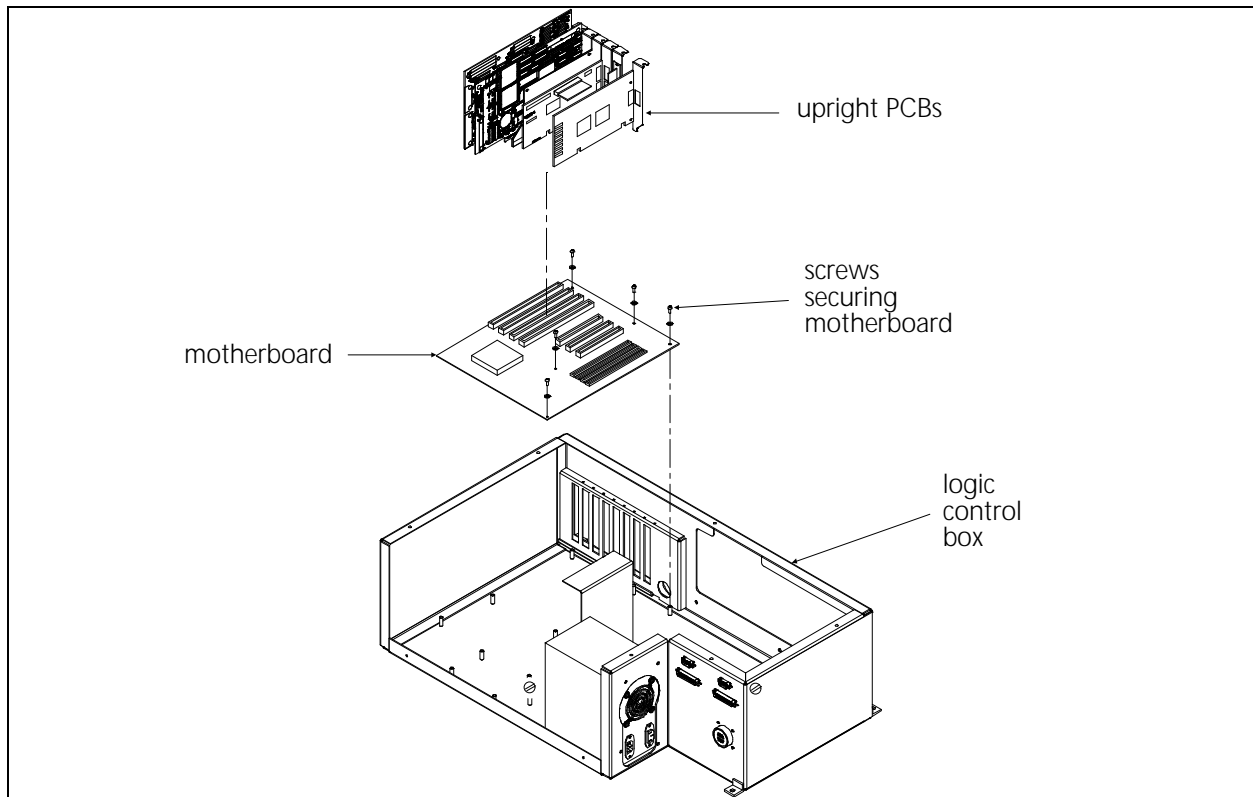

Figure 3 - 3

7. Grasp the computer motherboard at the corners of the board and carefully lift the board up and out of the base of the logic control box.



CAUTION! Once the motherboard is removed from the logic control box, use extreme care in handling it. Portions of this board are very sensitive to static charges. Any further handling of the motherboard must be done with the continued use of the static grounding strap until reinstalled.

To replace the motherboard, perform the previous steps in reverse order.

Low Voltage Driver PCB Replacement

The Low Voltage Driver PCB is located inside the logic control box. Refer to the following steps to remove this assembly:

1. Turn OFF the power switch to the EMC 10/12 and remove the power cord from the power source electrical outlet.
2. Remove the logic control box inner and outer covers as previously described.
3. Install a static grounding strap between the EMC 10/12 and the personnel performing this procedure.
4. Remove the various cables and harnesses from the PCB connectors.
5. Remove the six (6) screws that secure the low voltage driver PCB to the base of the logic control box (see Figure 3-4).

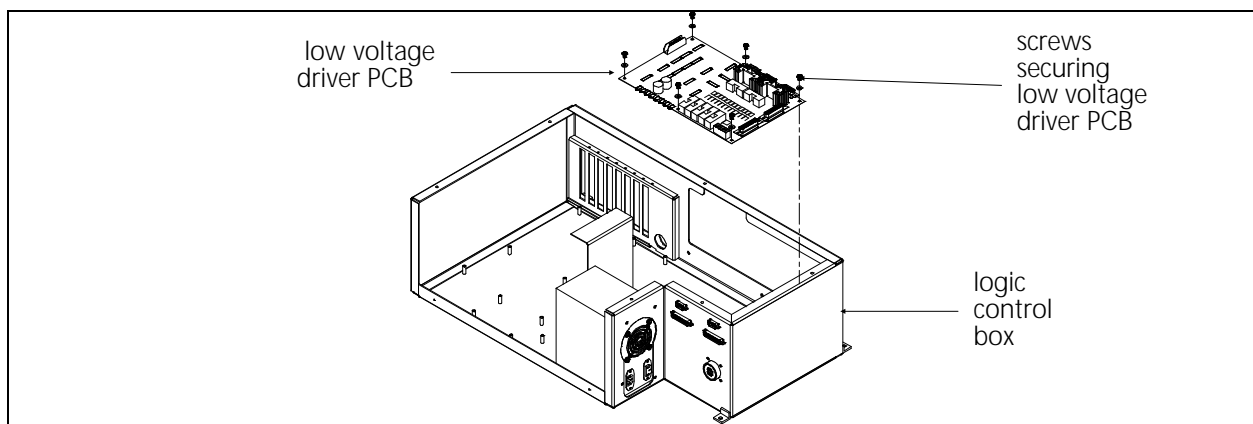

Figure 3 - 4

6. Grasp the assembly at the corners of the board and carefully lift it up and out of the base of the logic control box.



CAUTION! Once the low voltage driver assembly is removed from the logic control box, use extreme care in handling it. Portions of this board are very sensitive to static charges. Any further handling of the board must be done with the continued use of the static grounding strap until reinstalled.

To replace the low voltage driver assembly, perform the previous steps in reverse order.

Computer Keyboard Replacement

The computer keyboard (with trackball) may be easily replaced if worn, damaged, or generally non-functional. There are no parts inside the keyboard to be serviced, therefore it is replaced as a unit if it becomes defective.

1. Turn OFF the power switch to the EMC 10/12 and remove the power cord from the power source electrical outlet.
2. Remove the logic control box outer cover as previously described.
3. Unscrew the 2 thumb screws and disconnect the trackball cable from the 9-pin Dsub connector marked 'mouse' on the outside of the logic control box (see Figure 3-5).

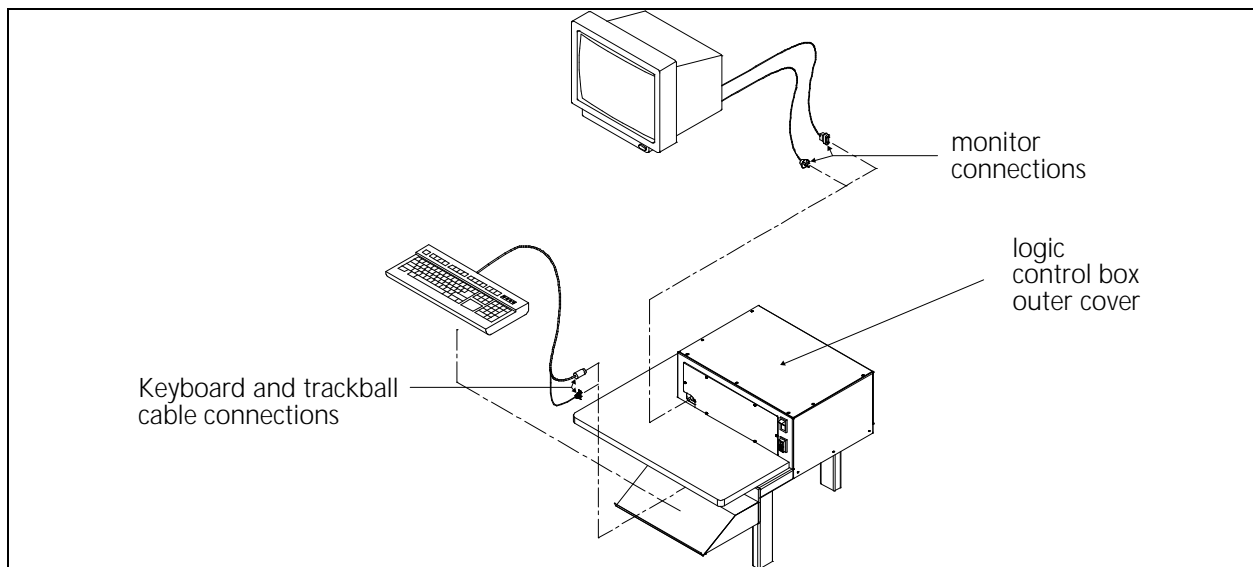

Figure 3 - 5

4. Unplug the keyboard cable from its location at the computer motherboard through the base of the upright PCB support bracket in the logic control box (see Figure 3-5).
5. Route the cable ends out of the logic control box.
6. To install a new keyboard/trackball assembly, route the cables of the new unit into the logic control box and reverse the steps used for removing the old unit.
7. Reinstall the logic control box outer cover and any other covers removed.

Monitor Replacement

The monitor may occasionally require maintenance or repair. There are no "user-serviceable" parts inside and high-voltage may be present even after the monitor has been fully disconnected. It is therefore advisable to leave any internal monitor repairs to a trained electronic technician.



WARNING! The monitor warranty may be void if the case is opened. Opening the case may lead to injury and/or electrical shock hazard!

1. Turn OFF the power switch to the EMC 10/12 and remove the power cord from the power source electrical outlet.
2. Remove the logic control box outer cover as previously described.
3. Unscrew the 2 thumb screws and disconnect the monitor video signal cable from the Dsub connector marked 'video' on the outside of the logic control box (see Figure 3-5).
4. Route the cable out of the logic control box.
5. Unplug the monitor power cord from the monitor power input connector.
6. Replace the defective monitor with a new unit by reversing the above steps, or have the existing monitor repaired by a trained electronic technician.
7. Reinstall the logic control box outer cover and any other covers removed.

Disk Drive Replacement

"FACTORY SERVICE ADVISED"

The external floppy disk drive is an IBM-standard 3.5" drive that operates from power obtained at the connector interface PCB inside the logic control box. To replace the floppy disk drive, refer to the following procedure.

1. Turn OFF the power switch to the EMC 10/12 and remove the power cord from the power source electrical outlet.
2. Move the monitor and keyboard from the support table onto the top of the logic control box cover.
3. Remove the keyboard support table.
4. Remove the right-hand cover of the color change box.
5. Disconnect the power supply cable connector and data cable connector from the rear of the disk drive unit. (Observe the connector orientation for re-installation later.)

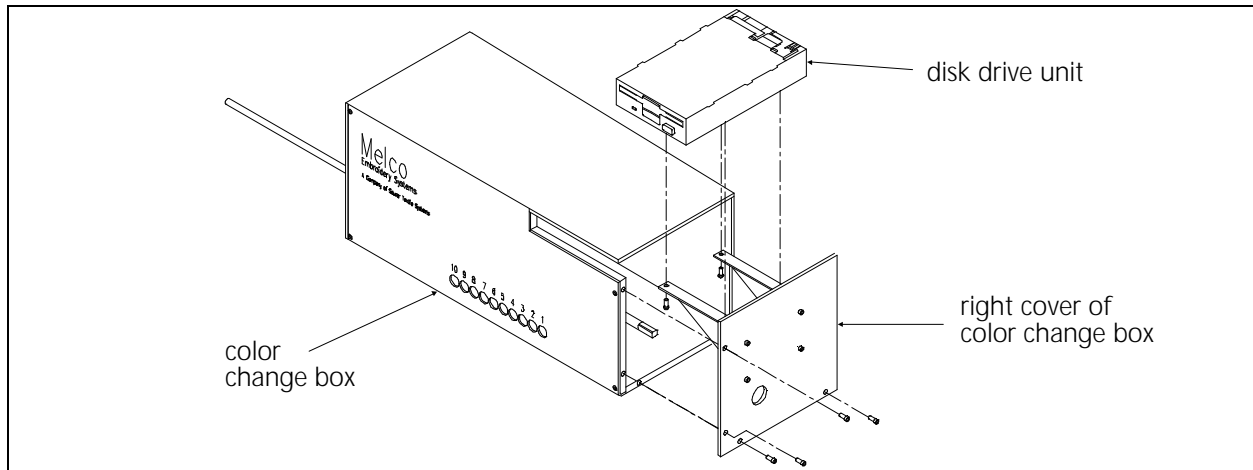

Figure 3 - 6

6. Remove the 4 mounting screws securing the disk drive to the mounting brackets on the color change housing right cover. The disk drive assembly should now be free to remove from the brackets.
7. Install the new disk drive by reversing the above steps.

Removing Front Panels And Covers

There are several covers attached to the front of the EMC 10/12. These covers may fill spaces between embroidery head parts and enclose harnesses associated with various devices mounted in this area. They also serve as panels to support and enshroud the devices in this area which include: the 7-button keypad, start/stop switches, emergency stop switches, tensioner brackets, and needle case assemblies.

To remove any of these covers, refer to the applicable step or steps below:

1. To remove any or all of the lower front covers (between needle cases), remove the 2 screws for each cover. Pull down slightly on the cover to remove the pin in the top of the cover from the hole in the bottom of the upper cover or panel, then remove the cover from the area.
2. To remove any or all of the covers or device panels between the tensioner brackets, you must first remove the lower front cover under the cover or panel you wish to remove. Next, remove the screws associated with the cover or panel and remove the cover or panel carefully. With the keypad or switch panels, you will have to disconnect the associated harness before removal.
3. The six covers over the rear of the tensioner brackets on each pair of embroidery heads are attached with 6 screws each that are removed to take off the selected cover.
4. To remove the left end tensioner cover, remove 1 screw behind the number 12 embroidery head tensioner bracket and 3 screws at the front, then carefully remove the cover to the left of the head.

5. To remove the right end tensioner cover, remove 1 screw behind the number 1 embroidery head tensioner bracket and 3 screws at the front, then carefully remove the cover to the right of the head.

To reinstall any or all covers and panels, reverse the associated steps above.

7-Button Keypad Replacement

To replace the 7-button control keypad, follow this procedure:

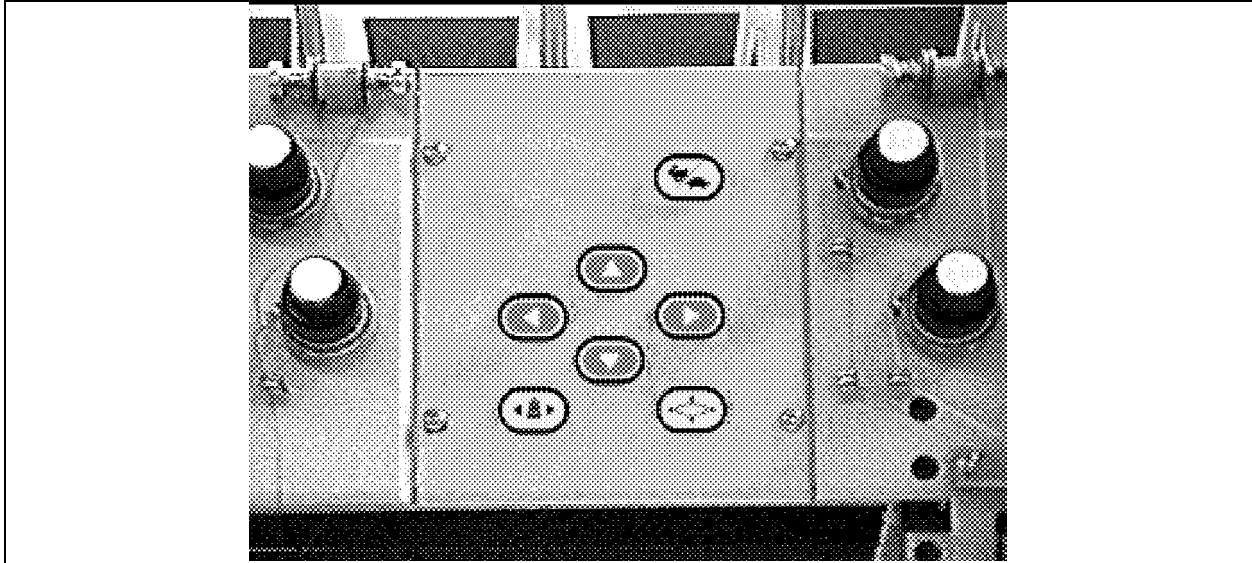

Figure 3 - 7 Keypad Panel

1. Turn OFF the power switch to the EMC 10/12 and remove the power cord from the power source electrical outlet.
2. Remove the associated rear tensioner bracket cover.
3. Disconnect the 12-strand cable from the back of the keypad printed circuit board.
4. Remove the lower front cover directly below the 7-button keypad.
5. Remove the four button-head screws that secure the 7-button keypad panel to the adjoining tensioner assemblies.
6. With the panel disconnected, remove the four screws that secure the keypad PCB to the back of the panel.
7. Replace the keypad with a new unit and reverse the above steps to re-install.

Replacing Start/Stop and Emergency Switches

These switches come in 2 basic parts and 2 basic configurations.

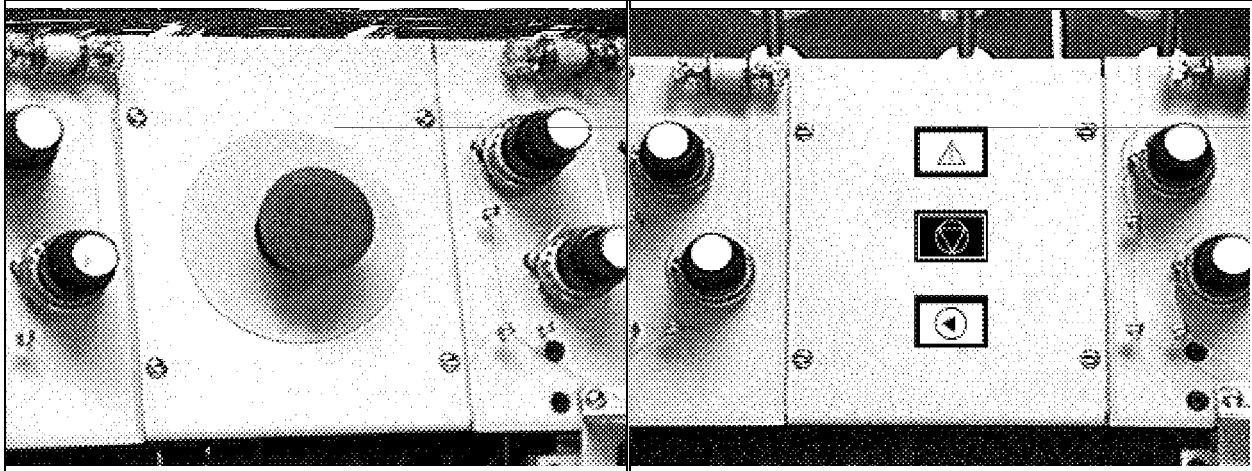

Figure 3 - 8 Emergency Stop Panel

Figure 3 - 9 Start/Stop Panel

Basic Parts

Each switch set comes with an actuator mechanism and the switch contacts. The actuator mechanism for the emergency stop switch is normally positioned outward; and locks inward when pressed. It is released to come back to the outward position with a clockwise twist. The start and stop actuators are normally positioned outward; and when pushed inward, only stay in that position as long as they are held there. When the actuator is released, it automatically comes back to the outward position. The actual mechanisms are identical for the start and stop switches except for the diagram on the front identifying the function.

Basic Configurations

The start and stop switches are normally open contacts that are temporarily closed for the specific function. The emergency switch is a normally closed contact that is opened (and held open with a twist-lock type switch actuator).

To replace either the start or stop switch in the start/stop switch panel or the emergency stop switch, follow this procedure:

1. Turn OFF the power switch to the EMC 10/12 and remove the power cord from the power source electrical outlet.
2. Remove the associated rear tensioner bracket cover.
3. Remove the lower front cover directly below the switch panel.
4. Remove the four screws that secure the switch panel to the adjoining tensioner assemblies.
5. With the panel disconnected, remove the switch contacts from the actuator mechanism by rotating the plastic lever at the junction of the contacts and actuator approximately 1/8 turn counter-clockwise (see Figure 3-10).
6. If replacing the switch contacts, loosen the screws holding the switch wire spade lugs in the rear of the defective switch contacts, and transfer the switch wires to the new switch contacts.

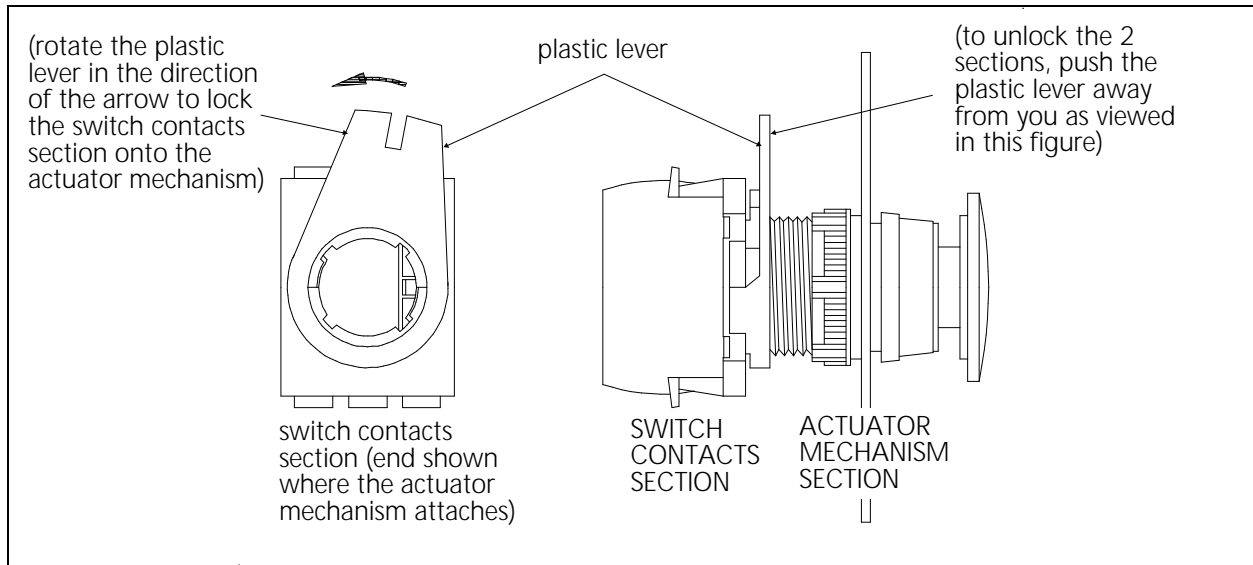

Figure 3 - 10 Separating Switch Contact from Actuator

7. If replacing the actuator mechanism, unscrew the nut on the rear of the panel and remove the positioning keyway washer. Then remove the rest of the actuator and the rubber washer out the front of the panel.
8. After removing the defective switch contact and/or actuator mechanism, replace the parts with new units and reverse the above steps to re-assembly the switch. Re-attach all panels and covers.

Carriage Section

Sash Frame Removal

Refer to the EMC 10/12 Operation Manual for sash frame removal and adjustment.

Replacing X and Y Drive Belts

"FACTORY SERVICE ADVISED"

The carriage X axis has two drive belts and the Y axis has four drive belts. Special tools are required to properly tension these belts after they are replaced. Improper belt tension adjustments will lead to premature wear of the belts, pulleys and bearings, and may produce diminished embroidery quality.

To replace any of the belts refer to the following procedure, then go to Chapter 2 in this manual for the applicable belt tensioning information.

1. Turn OFF the power switch to the EMC 10/12 and remove the power cord from the power source electrical outlet.
2. Move the sash frame all the way to the rear and to the right mechanical limits.

3. Remove the associated table top section for the Y drive belts or X drive belt cover.
4. Refer to Figure 3-11 and loosen the 4 locking dowel set screws in the outer belt clamping block (nearest the outside edge of the table surface).

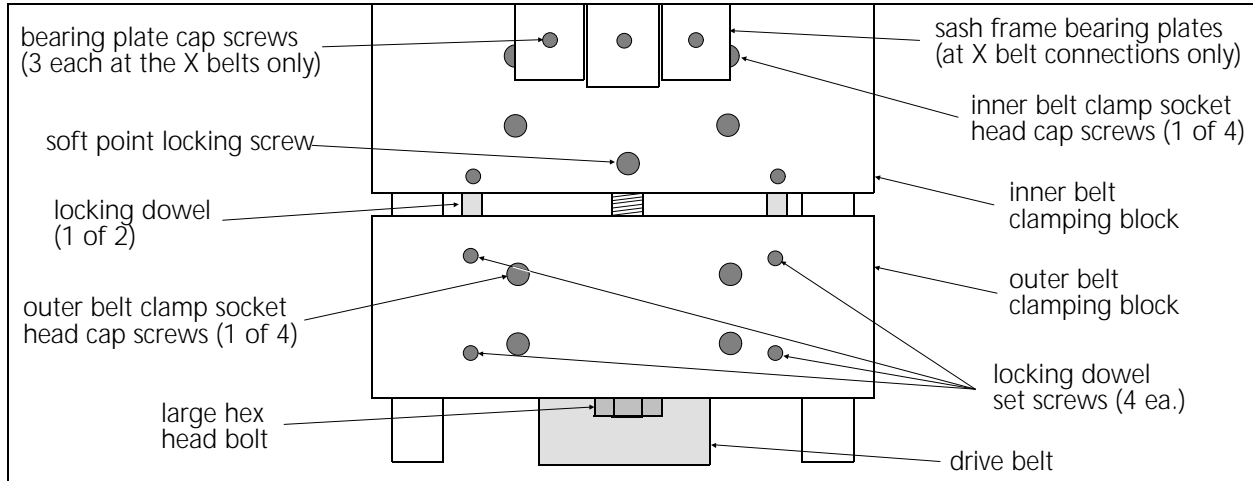

Figure 3 - 11 X or Y Drive Belt Coupling

5. Loosen the soft point screw locking the large hex bolt and rotate the large hex head bolt counter-clockwise with a 5/8 inch wrench to move the outer belt clamping block away from the inner belt clamping block. This loosens the belt.
6. Remove the bolt and slide the outer belt clamping block out as far as it will travel.
7. Loosen the belt clamp socket head cap screws to release the belt at the outer block.
8. Tape one end of the new belt to the loose end of the old belt.
9. At the X belt locations only, remove the six (3 at each X belt) bearing plate cap screws (see Figure 3-11).
10. At the X belt locations only, slide the sash frame bearing plates toward the sash frame enough to access the two inner belt clamp socket head cap screws under the two outside bearing plates.
11. Loosen all four of the inner belt clamp socket head cap screws to release the belt at the inner block.
12. Grasp the loose end of the old belt at the inner block and carefully pull on it as you assist at the other end by pushing on the new belt/old belt tape splice. As you perform this step, the new belt is moved into position to be attached to the inner and outer blocks.
13. When the new belt is in position, remove the old belt and tape and attach the new belt at the inner and outer blocks.

14. At the X belt locations only, reattach the sash frame bearing blocks and apply a slight amount of pressure on the middle blocks to take up the bearing slack of the sash frame bearings.
15. Ensure the sash frame is square to its mechanical alignments; and the belt teeth are engaged in the pulleys without any significant slack in the belt between the pulleys.
16. Move the outer block toward the inner block to take up the slack in the rest of the belt.
17. Attach the large hex head tensioning bolt.
18. Refer to the applicable belt tensioning section of Chapter 2 in this manual for the information in adjusting the belt tension.
19. Tighten the soft point locking screw onto the large hex head tensioning bolt to hold it in adjustment.
20. Tighten the 4 locking dowel set screws in the outer belt clamping block that you loosened at beginning of the belt removal procedure.
21. Reattach any table top section or drive belt covers removed for this procedure.

Under Carriage Section

X Motor And Motor Belt Replacement

"FACTORY SERVICE ADVISED"

Special tools are required to tension the carriage X axis motor belt properly after replacing the motor or belt. The belt must be properly tensioned to ensure accurate movement and prevent premature wear of the belt, pulleys, bearings and motor.

To replace the X motor and/or belt refer to the following procedures, then go to Chapter 2 in this manual for the applicable belt tensioning information.

1. Turn OFF the power switch to the EMC 10/12 and remove the power cord from the power source electrical outlet.
2. Remove the X motor belt cover.
3. Move the sash frame to its full right position.
4. Remove the limit X stop limit encoder belt.
5. Loosen the four socket head cap screws that secure the motor to the mount and back off the screw on the adjustment block.

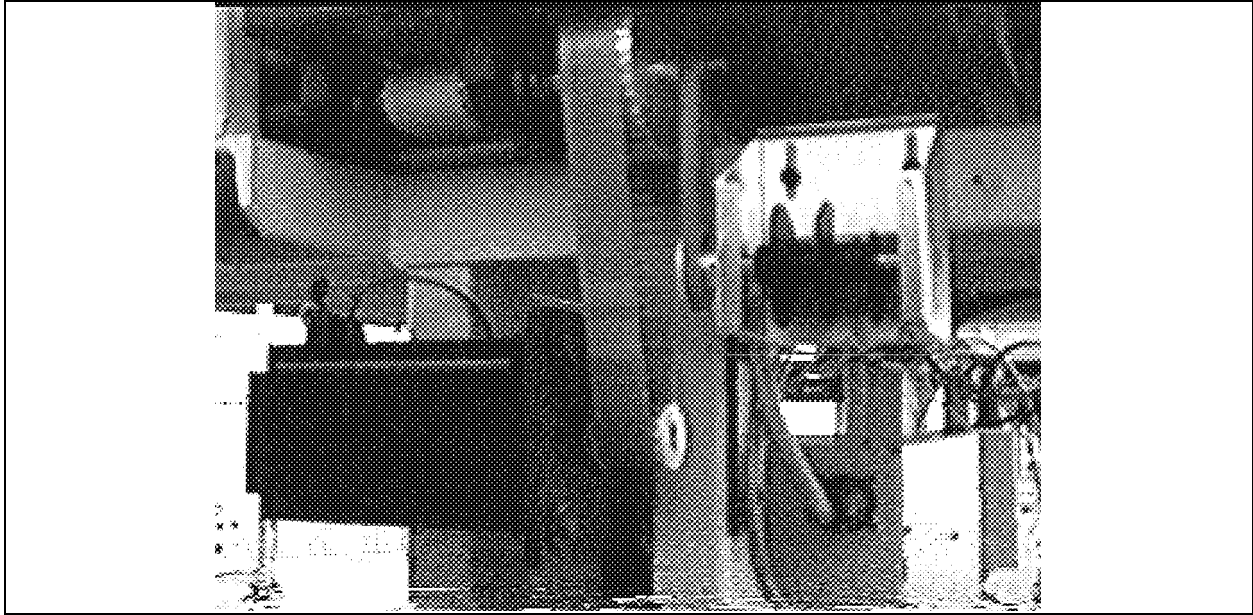

Figure 3 - 12 X Axis Motor and Belt

6. Slip the motor belt off of the motor shaft pulley and the X drive shaft pulley.
7. If replacing the motor, disconnect the associated wiring and harnesses, making note where to reattach them when installing the new motor.

NOTE: The motor power connections are made inside the power supply box.

8. Remove the socket head cap screws and take the motor off the mount.
9. Transfer the motor shaft pulley from the old motor to new motor, aligning the pulley the same distance on the shaft from the new motor body as on the old motor body.
10. Attach the new motor to the mount using the same socket head cap screws and tighten the screws.
11. Replace the wiring and harnesses associated with the motor at the locations as noted in the removal step.
12. Slip the belt onto the X drive shaft pulley and motor shaft pulley, then refer to the applicable belt tensioning section in Chapter 2 of this manual.
13. Reattach the limit X stop limit encoder belt and refer to the applicable belt tensioning section in Chapter 2 of this manual to tension it properly.
14. Check and adjust X stop limit encoder as described in Section 2 of this manual.
15. Re-install the associated table top section and motor belt cover removed earlier.

Y Motor And Motor Belt Replacement

"FACTORY SERVICE ADVISED"

Special tools are required to tension the carriage Y axis motor belt properly after replacing the motor or belt. The belt must be properly tensioned to ensure accurate movement and prevent premature wear of the belt, pulleys, bearings and motor.

To replace the Y motor and/or belt refer to the following procedures, then go to Chapter 2 in this manual for the applicable belt tensioning information.

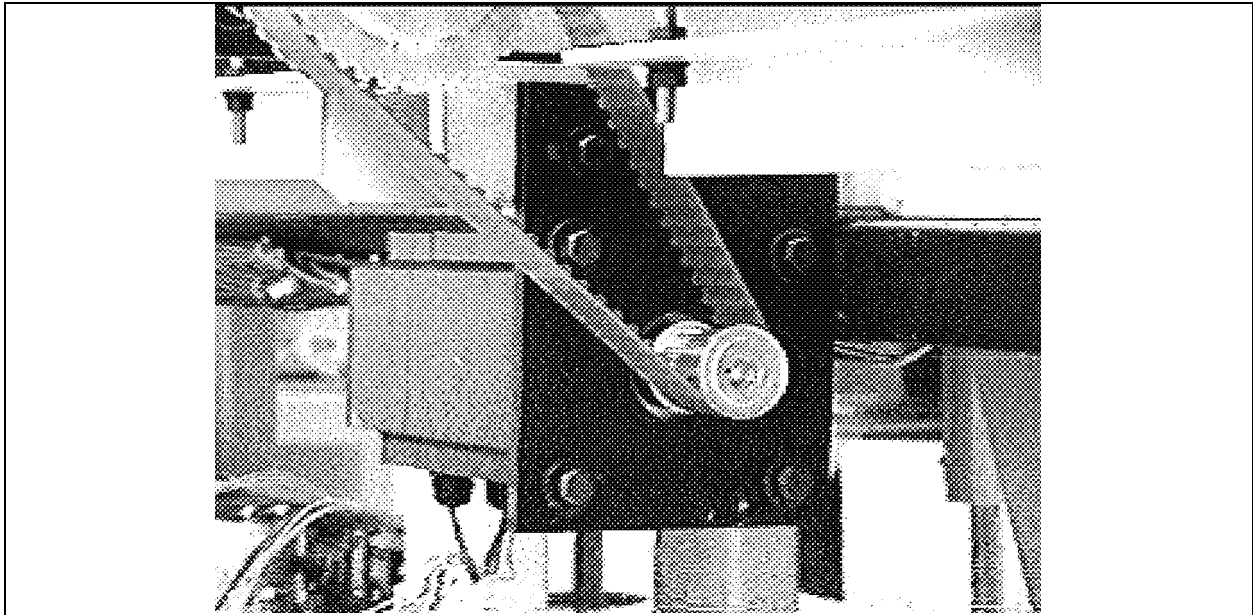

Figure 3 - 13 Y Axis Motor and Belt

1. Turn OFF the power switch to the EMC 10/12 and remove the power cord from the power source electrical outlet.
2. Remove the associated table top section and motor belt cover.
3. Move the sash frame to its full rear position.
4. Loosen the four socket head cap screws that secure the motor to the mount and back off the screw in the adjustment block.
5. Slip the motor belt off of the motor shaft pulley.

Refer to the appropriate section(s) on the following pages, depending on whether you are replacing a motor or belt or both.

Replacing Motor

If replacing belt only, skip this section and go to the Replacing Belt section.

6. Disconnect the associated wiring and harnesses, making note where to reattach them when installing the new motor.

NOTE: The motor power connections are made inside the power supply box.

7. Remove the socket head cap screws and take the motor off the mount.
8. Transfer the motor shaft pulley from the old motor to new motor, aligning the pulley the same distance on the shaft from the new motor body as on the old motor body.
9. Attach the new motor to the mount using the same socket head cap screws and tighten the screws.
10. Replace the wiring and harnesses associated with the motor at the locations as noted in the removal step.

If replacing the belt also, skip the next two steps and go directly to the beginning of the Replacing Belt section

11. Slip the belt back onto the motor shaft pulley, then refer to the applicable belt tensioning section in Chapter 2 of this manual.
12. Re-install the associated table top section and motor belt cover removed earlier.

Replacing Belt

Disregard this section if replacing motor only. When replacing the belt, you must disassemble a section of the Y drive shaft to slip the old belt off and the new belt on.

13. Ensure the sash frame is still located at its full rear position.
14. Locate the hex shaft coupler (looks like 3 hex nuts) on the Y drive shaft, just to the right of the Y drive shaft pulley (see Figure 3-14). The hex shaft coupler joins the 2 Y drive shaft pieces together.
15. Move the motor belt to the right of the 3 hex nut coupling of the two Y drive shaft pieces.

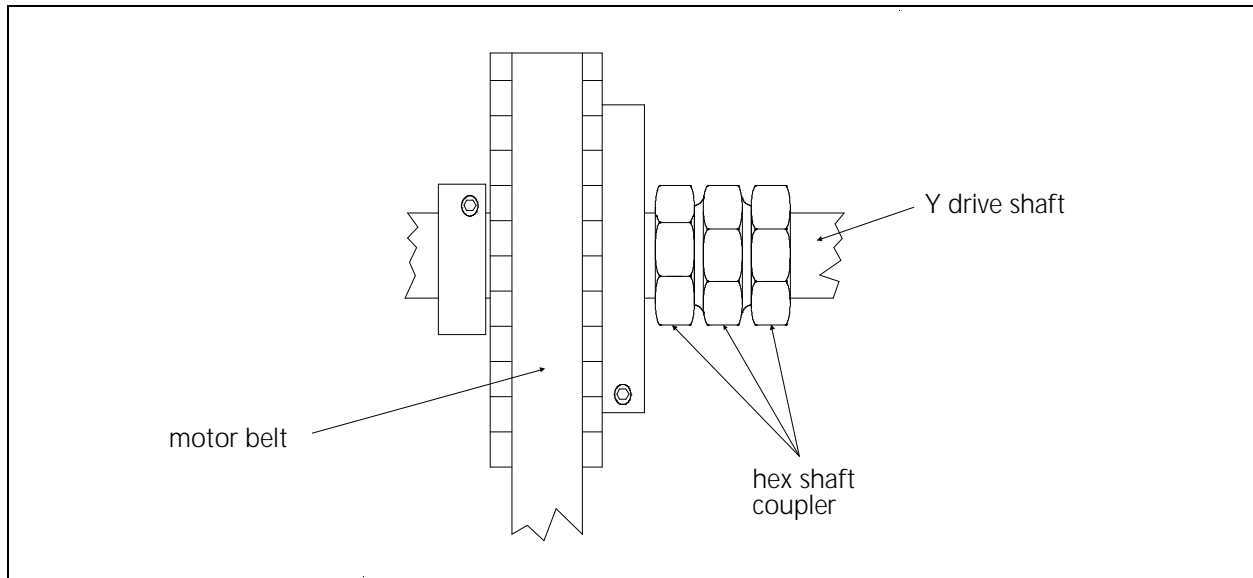
**Figure 3 - 14**

Note: To maintain positioning accuracy, do not allow the sash frame to move forward during the following several steps of this procedure.

16. While holding the center hex nut stationary with an open end wrench, rotate the right and left nuts counter-clockwise to remove them from the center nut.
17. Slide the 3 nuts to the right onto the right drive shaft piece.
18. Carefully flex the end of the right drive shaft piece downward only enough to slip the old belt off and the the new belt onto the shaft.
19. Move the 3 hex nuts back into position over the the 2 Y drive shaft pieces.
20. While holding the middle nut stationary, tighten the 2 outside nuts onto the middle nut to secure the 2 Y drive shaft pieces together. Torque these nuts to prevent the shaft pieces from slipping during rotation.
21. Slip the motor belt back onto Y drive shaft pulley and the motor shaft pulley, then refer to the applicable belt tensioning section in Chapter 2 of this manual.
22. Re-install the associated table top section and motor belt cover removed earlier.

Power Supply Assembly

This assembly (also called the Power Distribution Box) is mounted to the frame under the user station section at the right end of the unit. To remove the power distribution box refer to the following procedure and Figure 3-14.

1. Turn the machine OFF and disconnect the power source.
2. Loosen the 4 captive screws fastening the heatsink and swing it open.
3. Remove 9 screws holding the power distribution box cover and remove the cover.
4. Remove the motor cables; and remove the input power conduit and wires from the terminal strip.
5. Disconnect the remainder of the cables at the connectors on the power supplies.
6. Remove the 4 socket head cap screws that secure the power distribution box to the frame.



WARNING! The power distribution box is very heavy. Do Not attempt to remove the assembly unless properly prepared to handle the weight of the assembly as it comes off the frame!

7. Carefully lift the power distribution box out of its position in the frame.

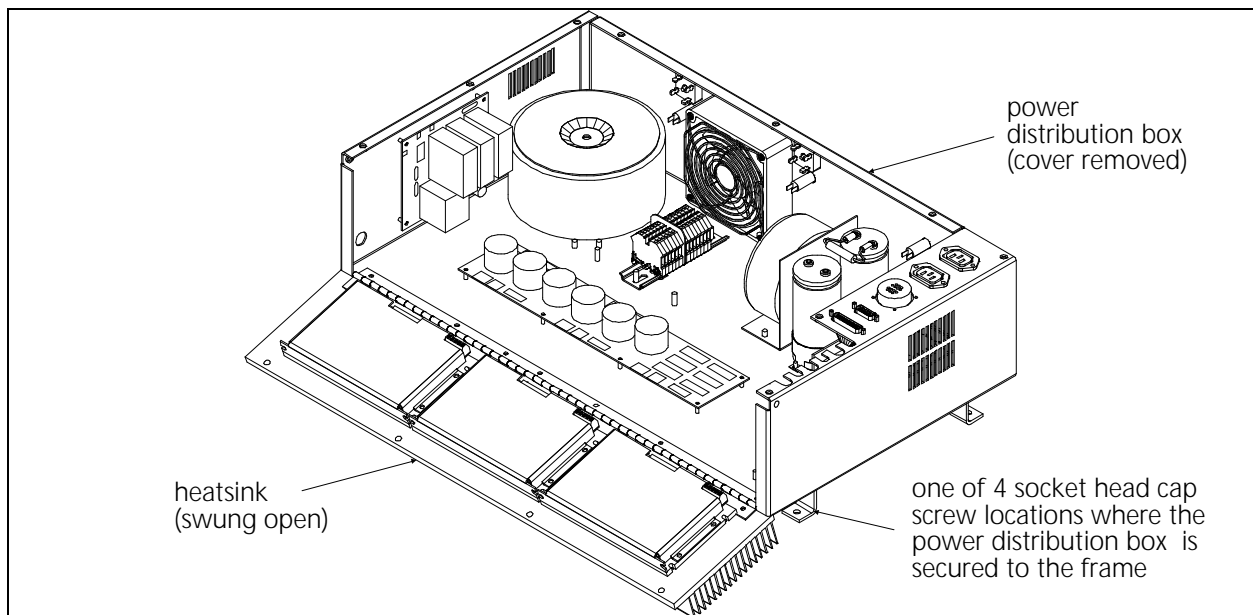

Figure 3 - 15

8. Perform the previous steps in reverse order to replace the assembly.

Motor Drive Modules

There are three identical XYZ motor drive modules located inside the power distribution box enclosure attached to the support frame. Access to the modules is gained by loosening the captive hardware on the power distribution box heatsink and lowering the heatsink.



WARNING! When the heatsink is lowered, and the machine is ON, harmful voltages are present.

The capacitors in this section may store very high voltage for a few moments after power is removed, therefore extreme care is advised when working in this area immediately after removing power.

It is advised that you delay any work in this area for at least one (1) minute after removing power, to allow the voltage in the capacitors to discharge.

If unauthorized personnel attempt to service this area, the Factory Warranty May Be Voided if the work is improperly performed. To replace one or more of the XYZ motor drive modules refer to the following steps:

1. Turn the EMC 10/12 OFF and disconnect the power source.
2. WAIT ONE MINUTE, then loosen the captive screws and lower the heatsink to gain access to the XYZ motor driver modules (see Figure 3-16).

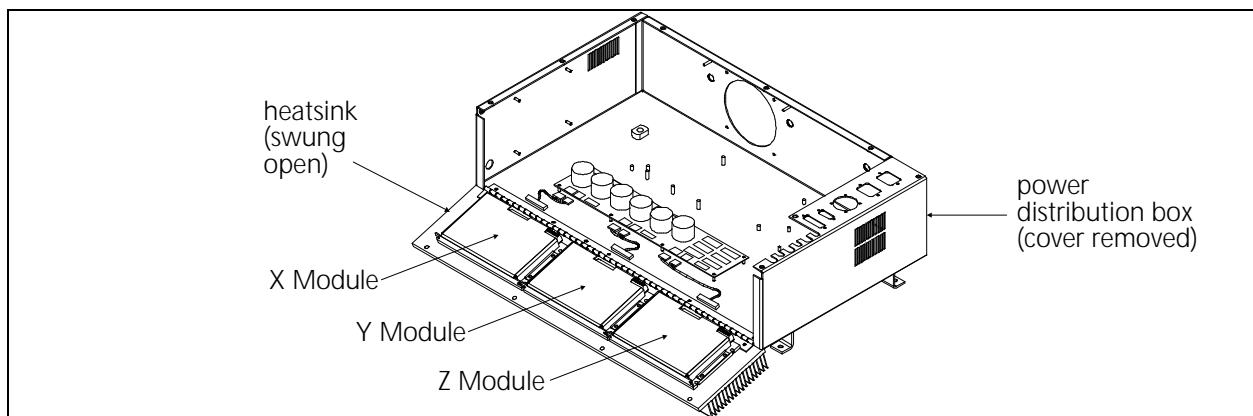

Figure 3 - 16 XYZ Controller Box

3. Disconnect the harnesses and remove the hardware associated with the defective XYZ motor drive module.
4. Remove the defective XYZ motor drive module.



CAUTION! Current-limit switches must be properly set on any new motor drive module before installing the module and attempting to operate the machine.

Setting Current Limit Switches

Before installing any new motor drive module, you must set the current limit switches on the module. The current limit switch setting is the same for the X and Y modules, but is different for the Z module.

5. Refer to Figure 3-17 and locate the current limit switches on the drive module as indicated.

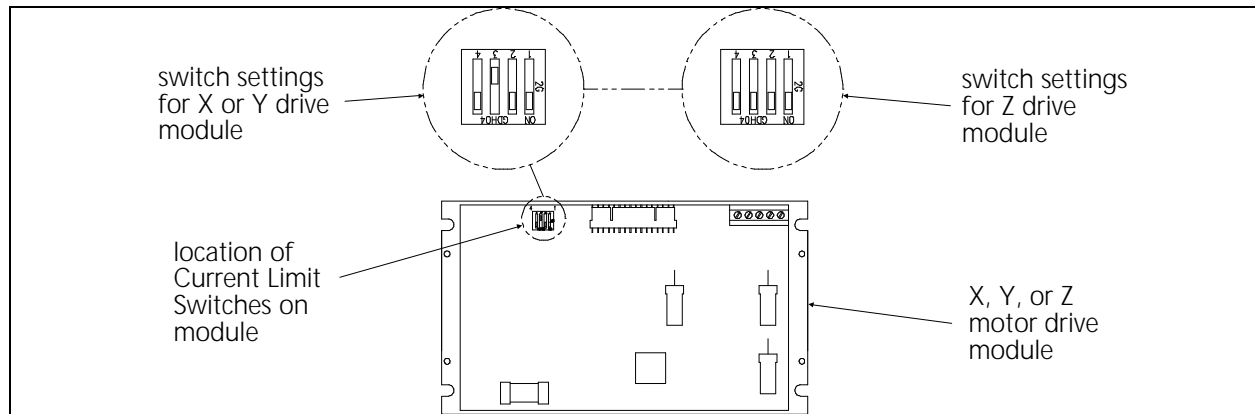

Figure 3 - 17

6. Using a small screw driver or other similar device, position the switch settings to the proper position

For X and Y modules: #1 ON, #2 ON, #3 OFF, #4 ON
 For the Z module: #1 ON, #2 ON, #3 ON, #4 ON

Install the new XYZ motor drive module using the same hardware.

7. Reconnect the harnesses that were disconnected during the removal of the defective module.
8. Resecure the heatsink, and make certain the screws are tight to prevent accidental loosening.

Embroidery Heads

The Melco EMC 10/12 features 12 identical embroidery heads that operate in unison. Each head consists of several smaller sub-assemblies. This section of the manual describes the removal and replacement of most of the major components of the embroidery head. Unless otherwise specified, each procedure applies to all embroidery heads and sub-assemblies.

Arm and Bed Assemblies

The individual arm and bed assemblies provide stable embroidery head platforms. All other components of the embroidery heads are attached to these assemblies. Inside the arm and bed assemblies are the shafts, belts, and pulleys that drive the needle and rotary hook.

Attached to the outside of the arm and bed assemblies are the needle cases and tensioners, color change mechanism, grabber and trimmer systems, and the mechanical Z drive system.

Z Motor Replacement

"FACTORY SERVICE ADVISED" A special tool is required for Z motor encoder adjustment after motor is replaced.

1. Turn the main power OFF, and remove the power source cable from the power distribution box.
2. Disconnect the Z motor harnesses from the power distribution box. Remove the Z encoder harness connector.

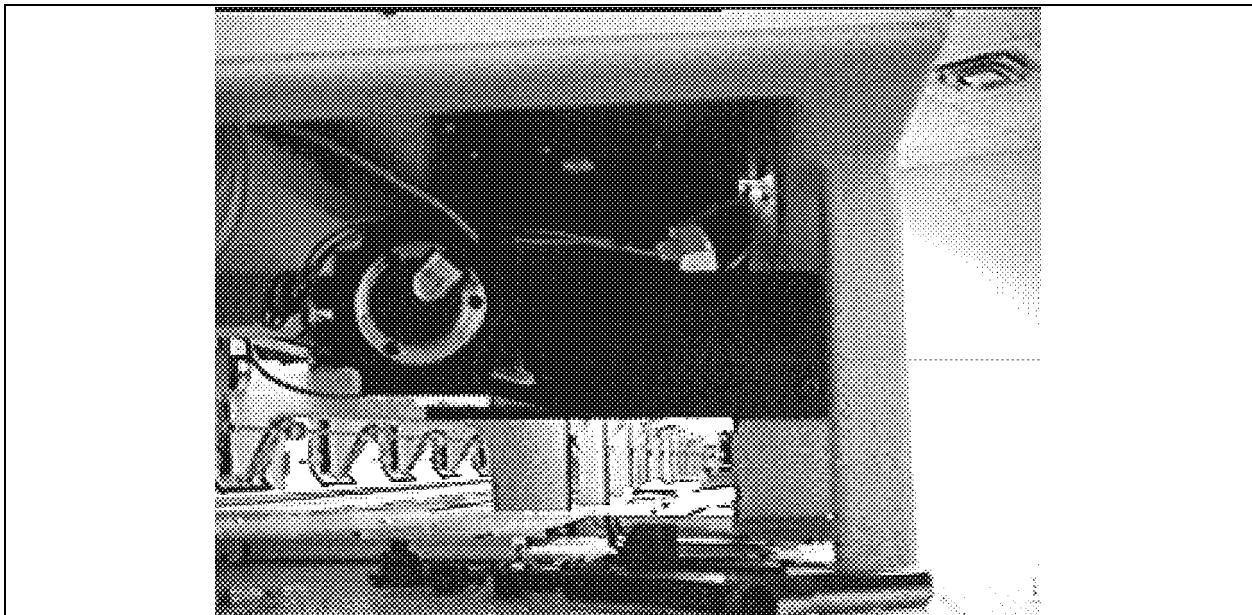

Figure 3 - 18 Z Axis Motor and Encoder

3. Remove the first, then loosen the second set screw (see note below) in each hole of the shaft coupler securing the Z shaft and the motor shaft (see Figure 3-19).

Note: There are 2 set screws in each hole of the shaft coupler. The first set screw tightens against the key and the other set screw tightens against the first set screw locking it in place.

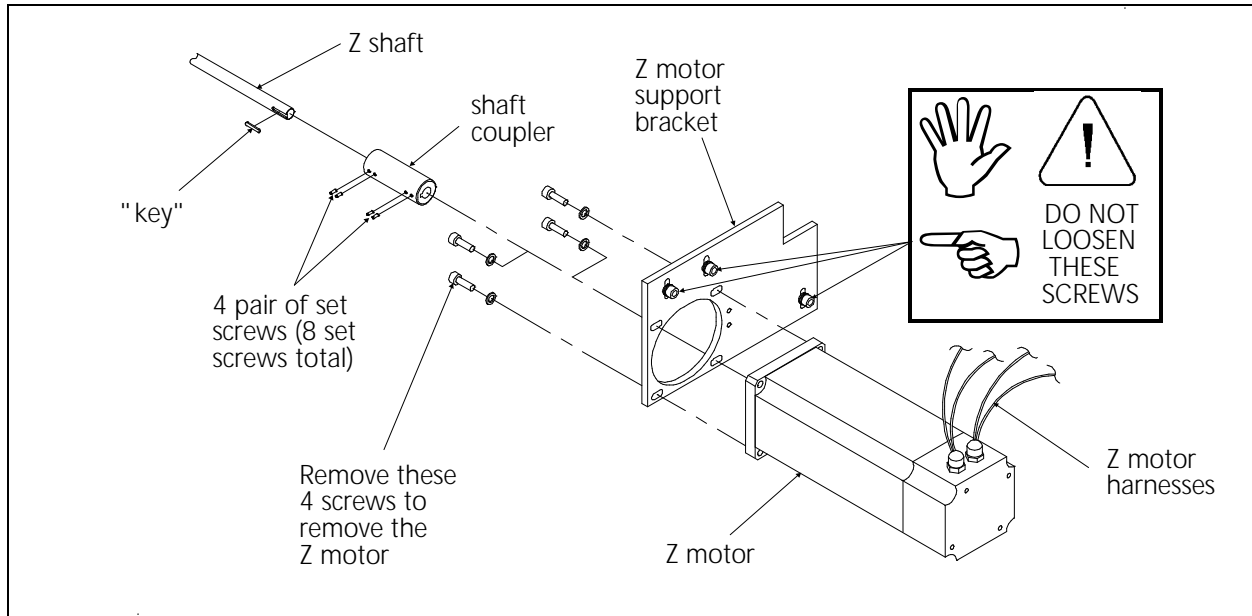

Figure 3 - 19

4. Slide the shaft coupler off of the motor shaft onto the Z shaft only and locate and remove the "key" from the shaft slots.



Caution! **DO NOT** remove the support bracket in the next step! It is set in place at the factory and should not be removed.

5. Remove only the four socket head cap screws attaching the motor to the motor support bracket and remove the motor from the bracket.



CAUTION! Do Not adjust the set screws or loosen the attaching screws in the motor support bracket. The bracket is factory set for motor vertical positioning and squareness to the Z shaft.

6. Place the new Z motor into position in the motor support bracket.
7. Install the four socket head cap screws and snug them slightly.
8. Adjust the motor position in the slotted holes until the shaft coupler slides onto the motor shaft smoothly.
9. Tighten the motor socket head cap screws completely and recheck the smoothness of the coupler installation.

10. Fit the "keys" into the slotted keyways in the motor shaft and Z shaft, and slide the coupler over the two shaft ends and keys.
11. Tighten the set screws in the four holes of the coupler to secure the shafts inside the coupler.
12. Re-attach the electrical harnesses to the power distribution box and encoder.
13. Refer to the Z Encoder Adjustment procedure in Section 2 of this manual to adjust the Z encoder.

Tensioner Assembly Panel Removal

1. Remove all threads from the needles, guides, tensioners and supply tubes.
2. Remove the thread supply tubes from the back of the tensioner panel by gently pulling the tubes one by one out of their individual holes.
3. Remove the screws holding the rear cover. It is not necessary to remove the cover itself, merely rotate it backwards to rest on top of the plastic wire channel.
4. Disconnect the five-strand wire connector on the back of the tensioner PCB (refer to Figure 3-20). Do not disconnect the connector leading into the plastic wire channel.
5. Remove the upper cover panels on either side of the tensioner assembly. If the upper cover panels have start/stop or emergency stop buttons, mark the wires and then disconnect them. If any wires are secured to back of the panel with plastic tabs, unscrew the tabs and set them aside.

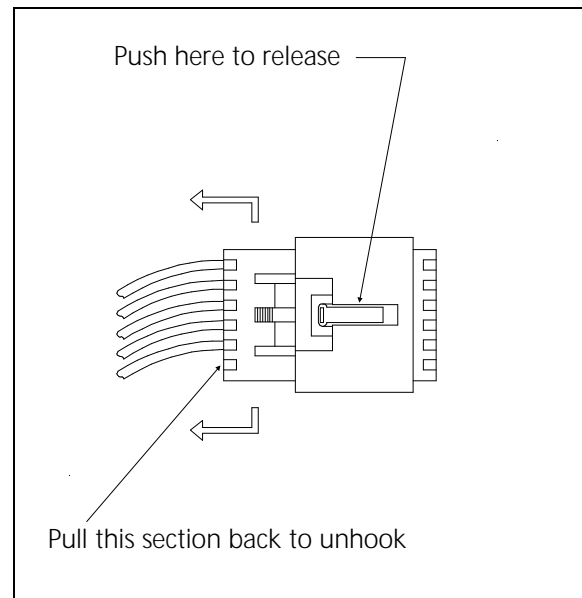

Figure 3 - 20

6. Remove the four screws holding the tensioner bracket assembly in place, then lift the tensioner bracket free from the mounting supports. Be careful not to damage the thread break brush assembly mounted on top of the embroidery head arm.
7. To install a new tensioner bracket assembly (or re-install the existing unit), merely reverse the proceeding steps.

Pre-Tensioner

The pre-tensioner consists of a knurled adjustment knob, a tension spring, and two beveled disks. These parts attach to a threaded post that is permanently mounted to the tensioner bracket. To replace any of the pre-tensioner parts merely unscrew the knurled knob. Refer to Figure 3-21 for re-assembly. For proper adjustment refer to the EMC 10/12 Operation Manual.

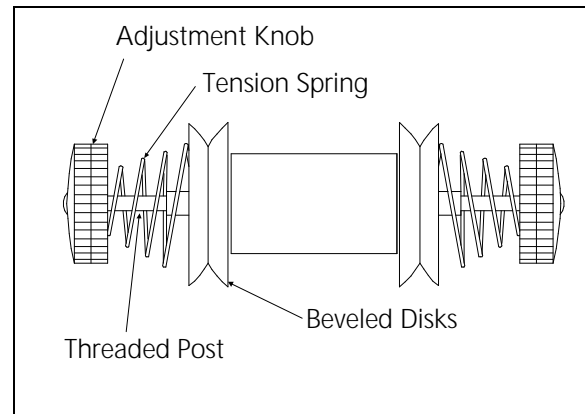

Figure 3 - 21

Replacing An Individual Thread Tensioner

Each thread tensioner is secured by a set screw against the thread tensioner shaft inside the thread tensioner bracket. The set screw is accessible through a slot at the top of the tensioner bracket.

1. Using a 2.5 mm allen wrench, loosen the set screw associated with the thread tensioner to be removed (see Figure 3-22).
2. Pull the thread tensioner out of the tensioner bracket.
3. To reinstall the thread tensioner, follow the procedure for changing a check spring.

Note: Be sure to fully seat the tensioner into the hole in the bracket.

4. After inserting the thread tensioner into the tensioner bracket,

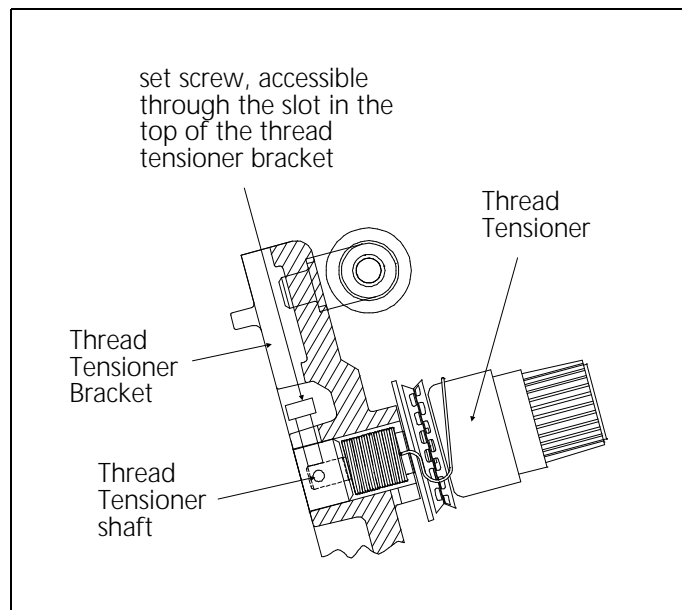

Figure 3 - 22

perform the thread tensioner check spring adjustment from Section 2 of this manual. This adjustment procedure, not only adjusts the check spring tension, but secures the thread tensioner in the tensioner bracket by tightening the set screw previously loosened in this procedure.

Changing A Check Spring

1. As described previously in this manual, remove the thread tensioner associated with the check spring that is being changed.
2. Remove the old check spring and discard it.
3. Attach the new check spring as follows:
 - a) Position the check spring around the end of the tensioner shaft as shown in Figure 3-23.
 - b) Insert the straight length of spring wire that is inside the check spring coil into the groove cut in the tensioner shaft as shown.

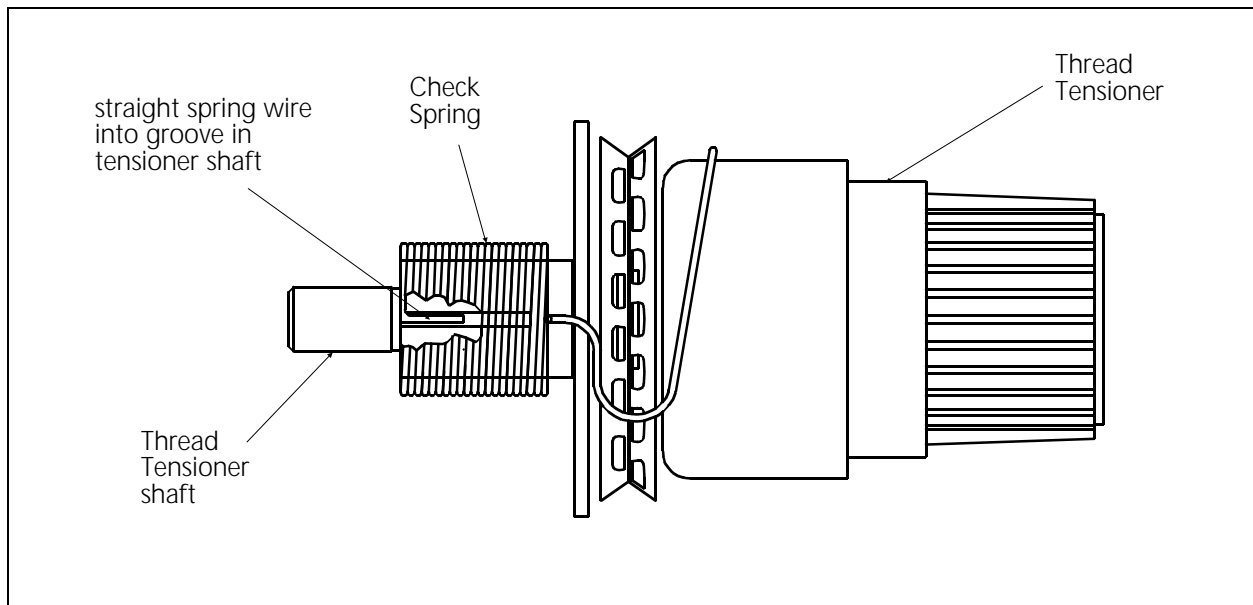

Figure 3 - 23

4. While holding the check spring in position, place the thread tensioner into the tensioner bracket. Insure the tensioner shaft seats into the smaller diameter hole in the bracket with the check spring still positioned on the tensioner shaft properly.
5. After inserting the thread tensioner into the tensioner bracket, perform the thread tensioner check spring adjustment from Section 2 of this manual. This adjustment procedure, not only adjusts the check spring tension, but secures the thread tensioner in the tensioner bracket by tightening the set screw loosened to remove the thread tensioner.

Replacing Other Thread Tensioner Parts

The individual thread tensioners may be disassembled by turning the knurled adjustment knob counter-clockwise until it comes free. Underneath the adjustment knob is a ribbed plastic disk and a tension spring. The knob, disk, and spring all nest within a large outer housing that, in turn, rests against a felt washer and the two-piece, notched thread wheel. The threaded shaft that retains the entire assembly is mounted to the tensioner bracket as described in the procedure for Replacing An Individual Thread Tensioner located earlier in this chapter.

Refer to Figure 3-24 for part location and assembly order when replacing any of these parts. For proper tensioning adjustment refer to the EMC 10/12 Operation Manual.

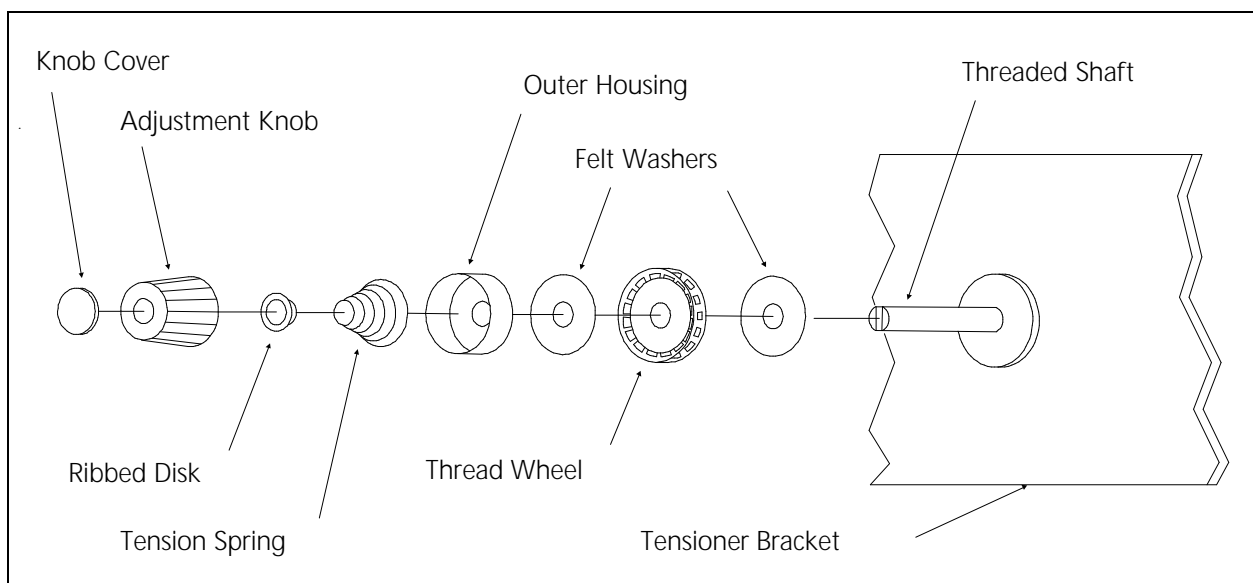

Figure 3 - 24

Replacing A Thread Break Contact Post

1. As described previously in this manual, remove the thread tensioner associated with the thread break contact post to be replaced.
2. Remove the thread break contact post by rotating it counter-clockwise out of its location in the thread tensioner bracket.



CAUTION! Use care not to cross thread the post when installing it during the next step.

3. Install the new thread break contact post by rotating it clockwise into the tensioner bracket. Secure the post "finger-tight" only.
4. You may apply a small amount of Loctite brand #222 screw adhesive or equivalent to keep the post from loosening.

Note: Do not use any stronger screw adhesive strength than above.

5. Reinstall the thread tensioner and check spring as described in a previous procedure in this section, then perform check spring adjustment from Section 2 of this manual.

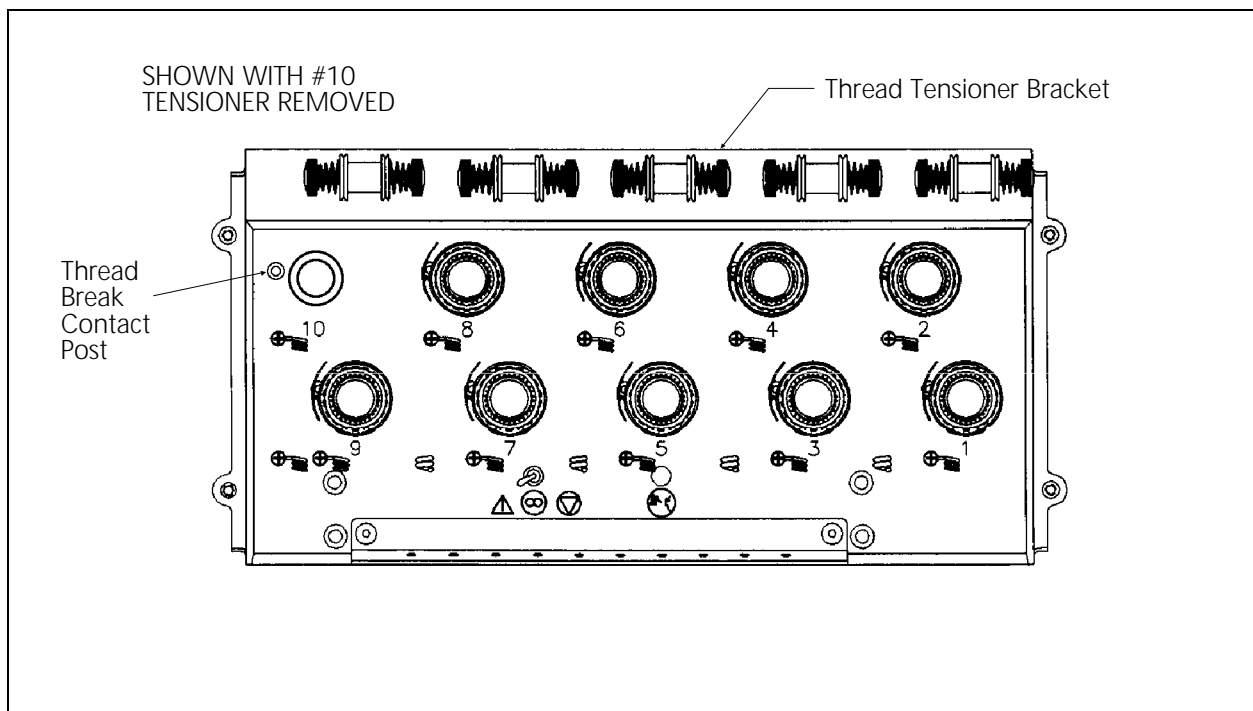

Figure 3 - 25

Replacing The Thread Break Contact Brush

1. Remove the rear tensioner bracket cover associated with the contact brush being replaced. (Refer to the cover removal section.)
2. Locate the thread break contact brush attached to the thread break bracket (see Figure 3-26).
3. Remove the thread break brush by removing the screw, thread break ground wire, and associated hardware that secures it to the bracket.
4. Replace the brush with the identical part to insure proper operation. Attach the screw, thread break ground wire, and associated hardware as shown in Figure 3-26.

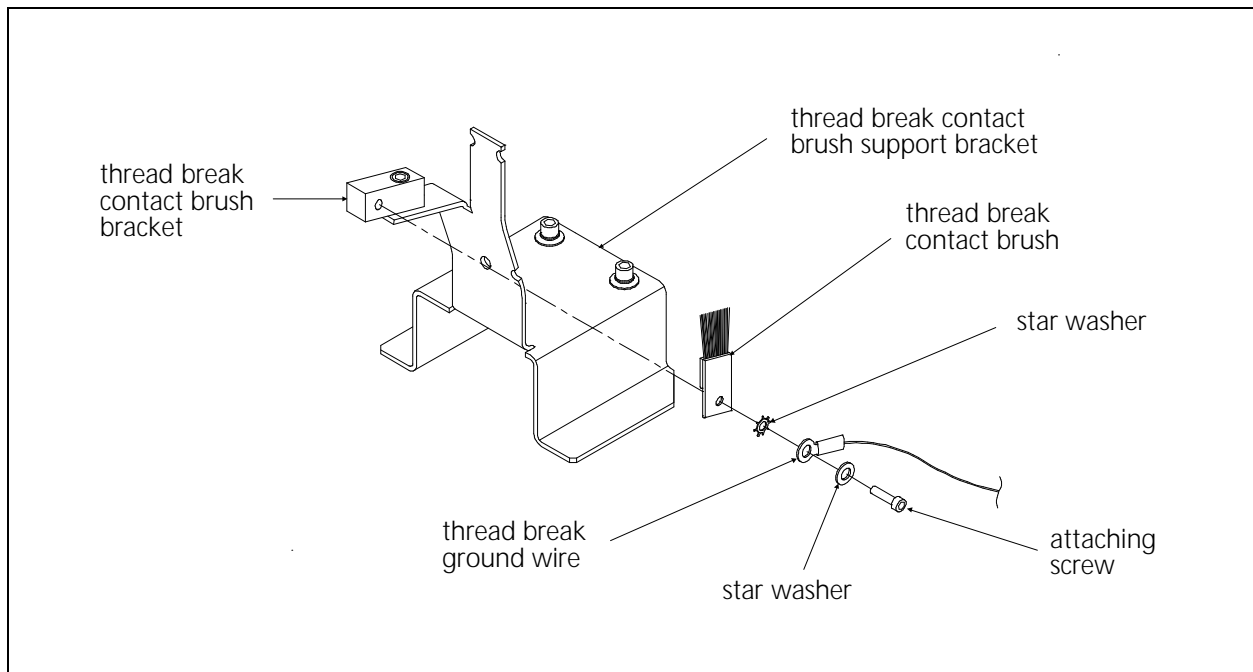

Figure 3 - 26

5. Refer to Section 2 of this manual for the adjustment procedure for the thread break contact brush.

Replacing A Needle Bar

To replace a needle bar, refer to the steps below, then turn to the Needle Bar Height Adjustment Procedure in the EMC 10/12 Operation Manual.

1. Turn ON the EMC 10/12 and bring the head to the HEAD UP position.
2. Turn OFF the EMC 10/12 and disconnect the power cord from its power source.

3. Refer to the procedure for removing the thread tensioner assembly and remove it as described in the procedure.
4. Remove the 2 screws holding the upper needle case cover plate and set the cover plate aside (see Figure 3-27).

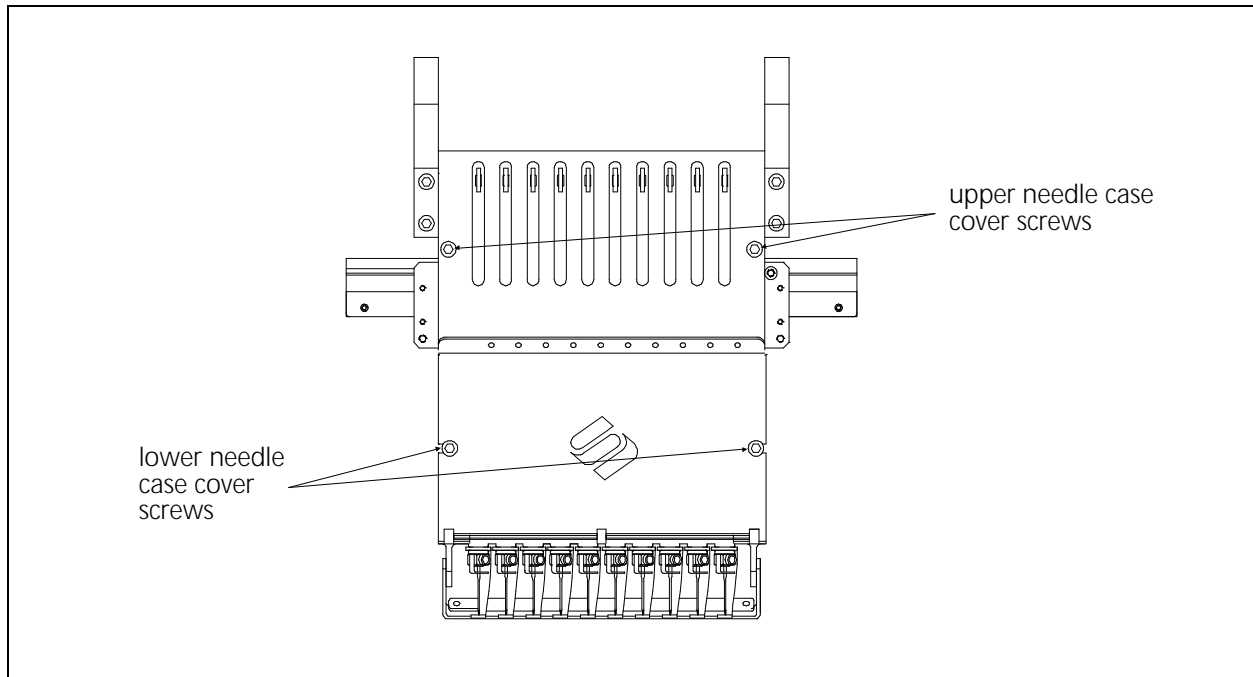

Figure 3 - 27

5. Loosen one screw and then remove the other screw holding the lower needle case cover plate and set the cover plate aside. You may now access the needle bar area to remove any of the 10 needle bars out through the top of the needle case.
6. Refer to Figure 3-28 and then loosen the needle clamp set screw and remove the needle, needle clamp, and needle clamp damper from the bottom of the needle bar.
7. Next, loosen the needle bar stop clamp (black clamp).
8. Loosen the top screw (see Figure 3-28) on the needle bar. (You will remove and transfer the screw in step 11.)



CAUTION! After the next step, the needle bar is free to be moved out the top of the needle case. Use care so the springs and other parts do not suddenly fly out of position.

9. Loosen the needle bar clamp.

10. Carefully capture and retain the various parts that become released by the needle bar as you remove the needle bar upward and out the top of the needle case.
11. Transfer the screw from the top of the old needle bar to the top of the new needle bar. Apply Loctite screw adhesive number 222 or equivalent to the screw if possible.
12. Install a new needle bar by inserting it from the top of the needle case and through the various pieces in the order shown in Figure 3-28.
13. Install a new needle into the needle clamp and tighten the needle clamp screw to secure the needle and capture the needle bar.

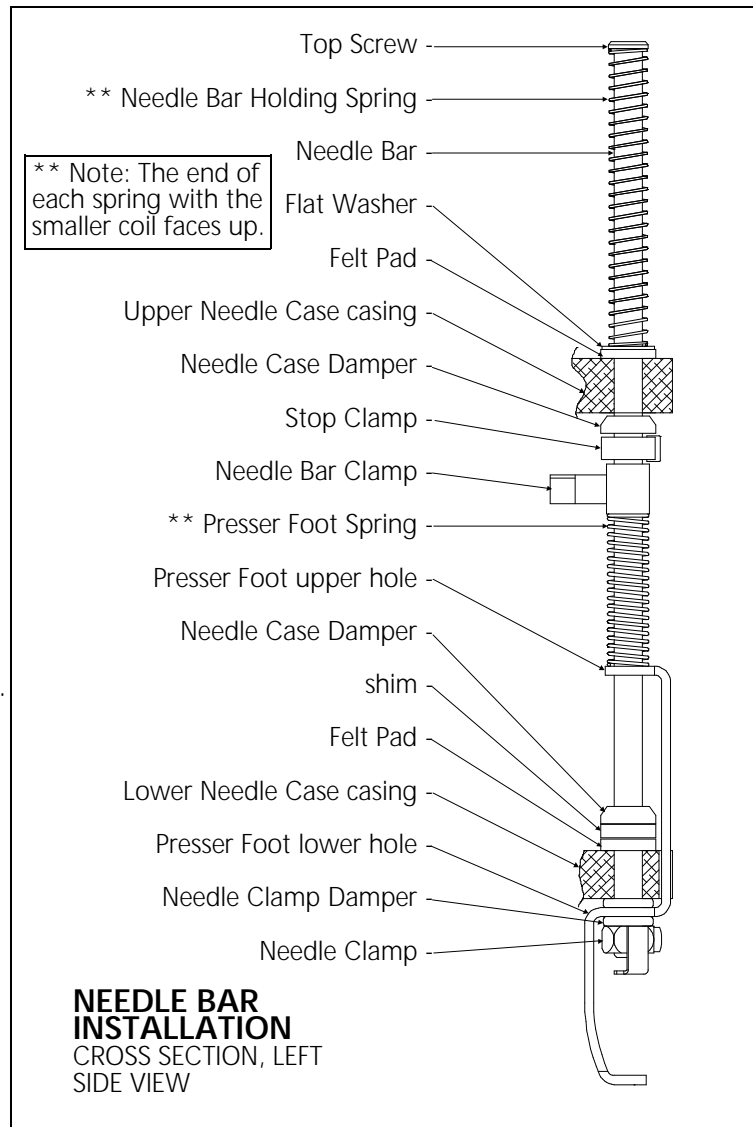

Figure 3 - 28

14. You may reinstall the upper needle case cover at this time. The lower needle case cover must, however, remain off to perform the needle bar height adjustment.
15. After installing a new needle bar, you must adjust the needle bar height. Refer to the EMC 10/12 Operation Manual for the adjustment procedure for needle bar height.
16. When the needle bar height has been properly adjusted, reinstall the lower needle case cover.

Needle Case Removal

It may become necessary to remove a needle case from the front of an embroidery head to replace the needle bar driver, take up lever gear, needle bar reciprocator, or other associated parts. Refer to the following steps and Figures 3-29 through 3-32 to remove the needle case from an embroidery head.

1. Turn ON the EMC 10/4 and bring the head to the HEAD UP position.
2. Turn OFF the EMC 10/4 and disconnect the power cord from its power source.
3. Remove the 2 lower front covers on either side of the needle case.

For the number 2 through number 11 embroidery heads, you do not need to remove the tensioner assemblies to remove the needle case.

For the number 1 and number 12 embroidery heads, you must remove the end cover and either provide support for the tensioner assembly or remove it before removing the needle case.

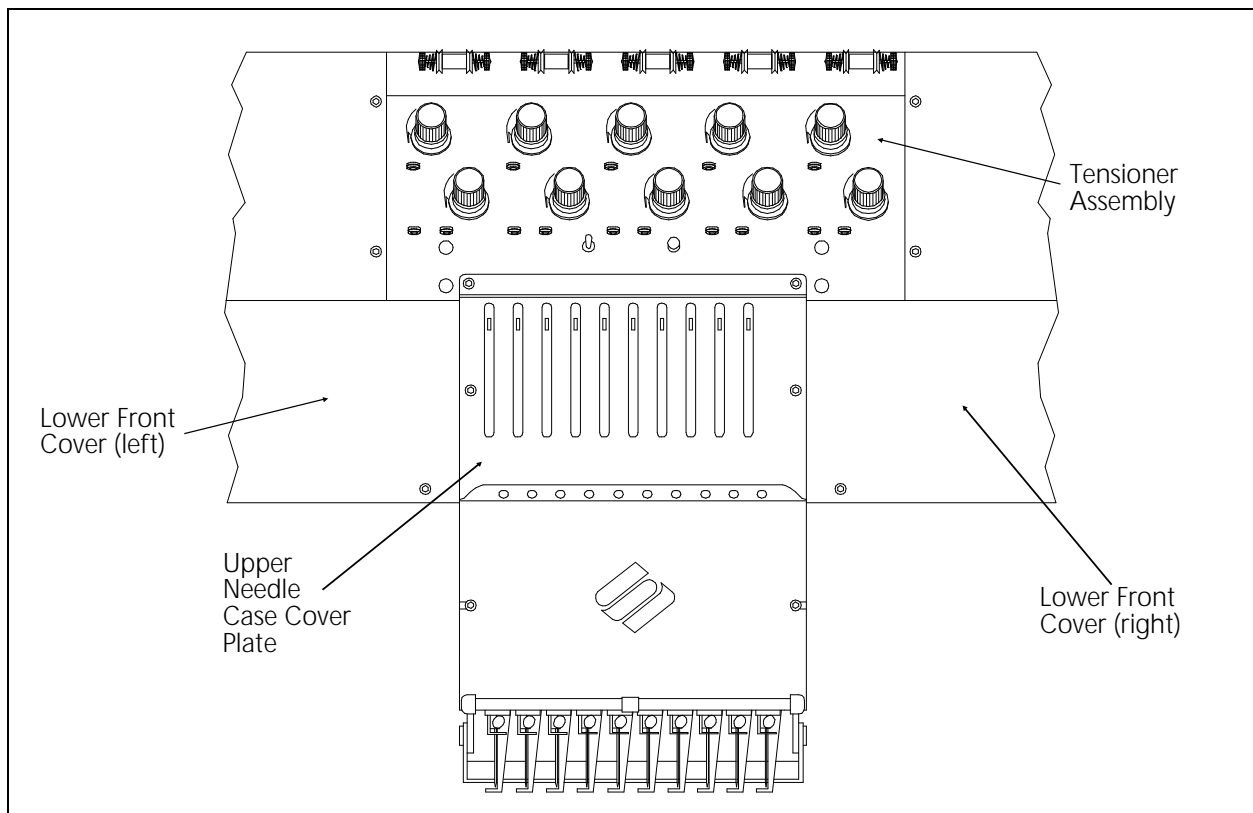

Figure 3 - 29

4. Refer to Figure 3-30 and remove the four socket head cap screws designated "A" which attach the needle case to the tensioner brackets.

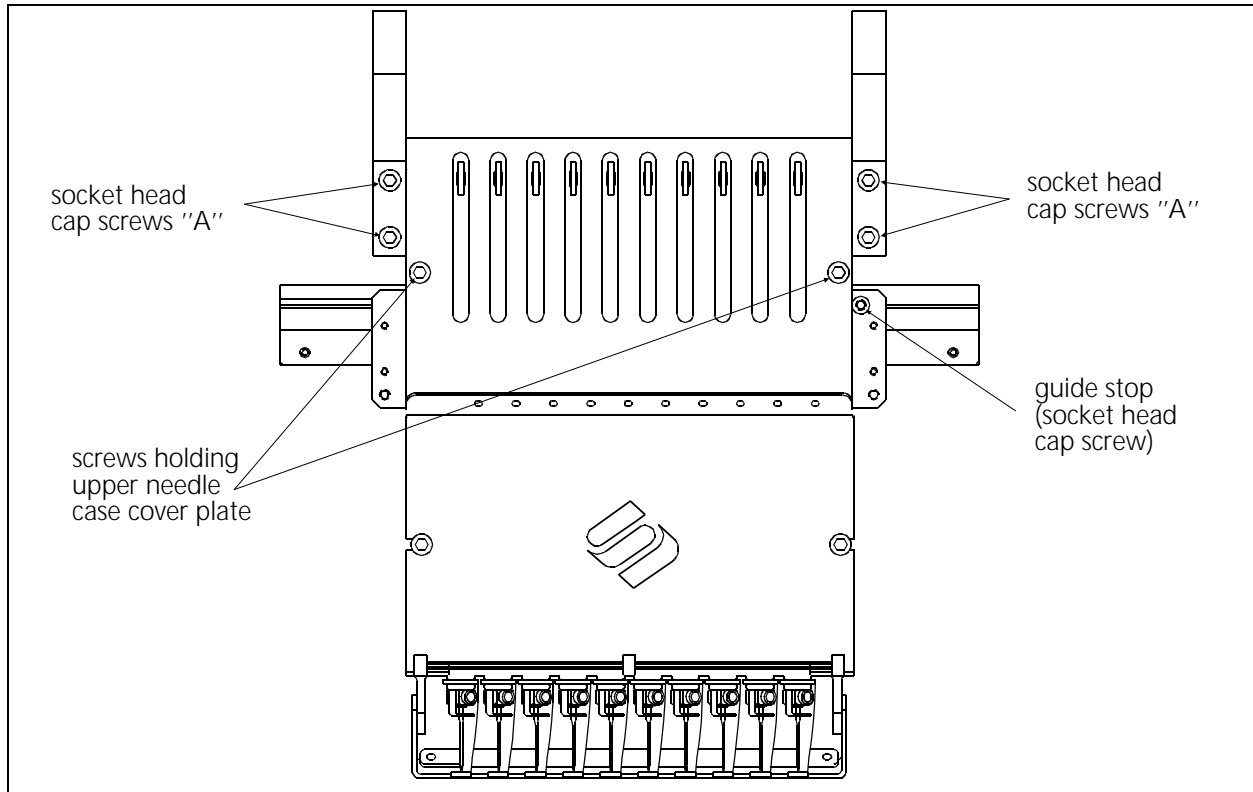

Figure 3 - 30

5. Remove the 2 screws holding the upper needle case cover plate and set the cover plate aside.
6. Hold the needle case securely with one hand while you remove the 4 socket head cap screws "B" that secure the needle case to the bearing retainer plate assembly near the top of the needle case.

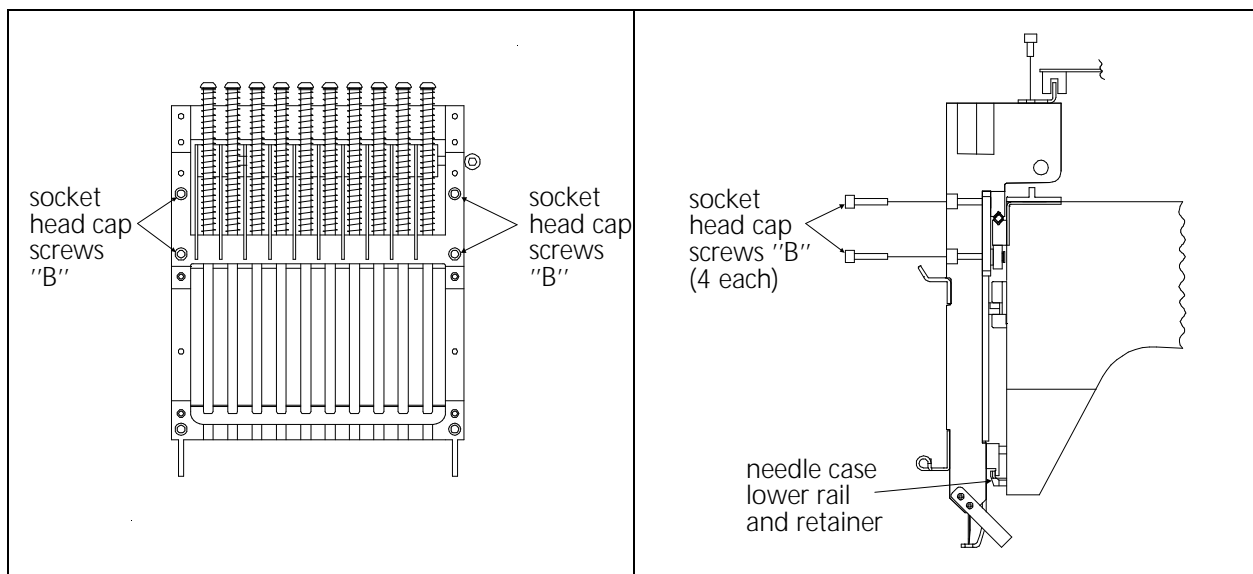

Figure 3 - 31

Figure 3 - 32

7. Lift the needle case slightly to disengage the lower rail from the lower rail retainer coming from the bottom of the embroidery head arm.
8. The needle case will now be free to remove from the the embroidery head.

Using care not to damage any components, set the needle case aside.

Installing Needle Case

To reattach the needle cases refer to Figures 3-29 through 3-32 and the following procedure:

1. Insure the following conditions are set:
 - a) The cross roller bearing is properly installed and centered. Refer to Section 2 of this manual for adjustment procedure.
 - b) The retainer plate assembly bearings are properly adjusted. Refer to Section 2 of this manual for adjustment procedure.
 - c) The embroidery head is at its mechanical "head up" position.
2. Refer to Figure 3-32 on the previous page and insert the needle case lower rail into the lower rail retainer. Insure the grabber blade fits into the grabber bar assembly at the bottom of the needle case.
3. Move the upper part of the needle case into position on the front of the embroidery head as you insure the following alignments:
 - a) All the take up lever slots are positioned onto the take up lever guide rail and the active take up lever gear teeth are engaged with the take up lever drive gear teeth. With the embroidery head still in the head up position, insure the top tooth of the take up lever drive gear engages with the 5th "valley" of the take up lever gears.
 - b) The needle case rests solidly and completely on the bearing retainer plate assembly and is positioned to the right so the right side of the needle case is against the guide stop (socket head cap screw) in the right side of the bearing retainer plate as shown in Figure 3-30 located two pages back.
4. Align the 4 through holes on the upper section of the needle case with the 4 threaded holes in the bearing retainer plate assembly.
5. Align the right edge of the needle case against the guide stop on the bearing retainer plate (see Figure 3-30).

6. Install the 4 "B" socket head cap screws; then the 4 "A" socket head cap screws (see Figures 3-30, 3-31, and 3-32). Snug the screws but do not tighten them at this time.
7. Pull the needle bar that is above the needle plate hole down until it locks in place just above the needle plate.
8. Insert the hex wrench in the left end of the Z shaft and slowly rotate the clockwise until the needle just begins to enter the needle plate hole.
9. Check that the needle enters the needle plate hole in the center and does not come near the edges.
10. If the needle is not centered properly in the needle plate hole, refer to the Color Change Link Bar Adjustment (Needle Centering) procedure in Section 2 of this manual.
11. Reinstall the upper needle case cover plate and attach it with the 2 screws.
12. Reattach the 2 lower front covers on either side of the needle case that were removed earlier.
13. If working with the number 1 and number 12 heads, reattach the end cover.

Replacing Needle Case Cross Roller Bearing

Refer to the figures within the needle case removal and installation procedures for this procedure.

1. Remove the needle case as described previously in this manual.



CAUTION! In the next step, some retainer plates may become free to move off the sides of the heads if bumped. To account for this possibility, you should attach a clamping device on the outside ends of the long v-rail mounted on the head.

2. Loosen the clamps holding the needle case linkage shafts and remove the linkage shafts from both sides of the head being worked on.
3. Carefully slide the bearing retainer plate assembly with cross roller bearing off either end of the V-rail.
4. Position the new cross roller bearing onto the V-rail and install the bearing retainer plate assembly. Refer to the cross roller bearing adjustment procedure in Section 2 of this manual.
5. Check for proper adjustment of the bearing retainer plate assembly bearings by referring to the adjustment procedure for bearing retainer plate assembly bearings also found in Section 2 of this manual.

6. Reinstall the needle case as described previously in this manual.
7. Position the needle case linkage shafts to both sides of the needle case.
8. Align the needle cases with the needles roughly centered in the needle plate holes.
9. Snug the linkage shaft clamping screws, do not tighten them at this time.
10. Remove the first segment of the Z-axis drive shaft cover.
11. Slowly rotate the Z axis until the needles begin to enter the needle plates. Carefully check the alignment of the needles within the needle plates.
12. Loosen the linkage shaft clamping screws and move the needle cases as needed to adjust all the needle cases for needle centering, then fully tighten the screws.
13. Replace the top needle case cover and tighten the two button head screws.
14. Replace the lower front covers and tighten their button head screws.
15. Re-verify that the needle is correctly aligned within the needle plate and that the grabber blade is seated between the contact brush assembly.
16. Replace the cover over the first segment of the Z axis drive shaft.

Reciprocator Replacement

It is recommended that the entire reciprocator assembly be replaced if problems are isolated to this area. There are some critical adjustments required when replacing individual parts. Also, if one component has failed, the other parts may be worn to the point of near failure and it would be prudent to replace them all at the same time. To remove and replace the reciprocator assembly, refer to the following procedure.

1. Refer to the Needle Case Removal procedure and remove the needle case.
2. Remove four button head screws holding the left and right arm cover plates. (see Figure 3-33)
3. On the lower left side of the embroidery head arm, loosen the needle bar guide shaft set screw.
4. Remove the snap ring at the base of the needle bar guide shaft.

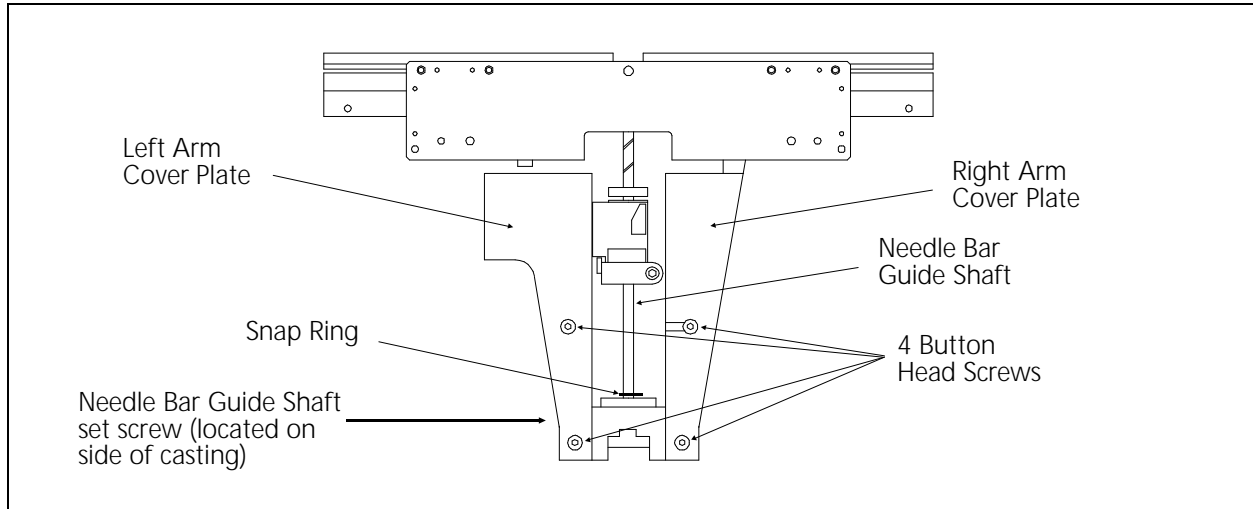

Figure 3 - 33

5. Locate the wicking felt on top of the embroidery head and remove it. Be careful not to damage the felt.
6. Push the needle bar guide shaft upward until it hits the thread break bracket.
7. Rotate the Z shaft with the hex wrench in the left end of the shaft until the reciprocator is free from the needle bar guide shaft.
8. Reverse the above procedure to install the new reciprocator assembly.

Jump Stitch Solenoid Replacement

If a jump stitch solenoid must be replaced, follow these steps:

1. Gently pull the two wires and associated jump stitch harness from within the plastic cable way. Disconnect the connector.
2. Remove the two screws and take off the mechanical jump stitch mechanism and cover to the jump stitch bracket (see Figure 3-34).
3. Remove the 2 jump stitch solenoid bracket screws (see Figure 3-35).

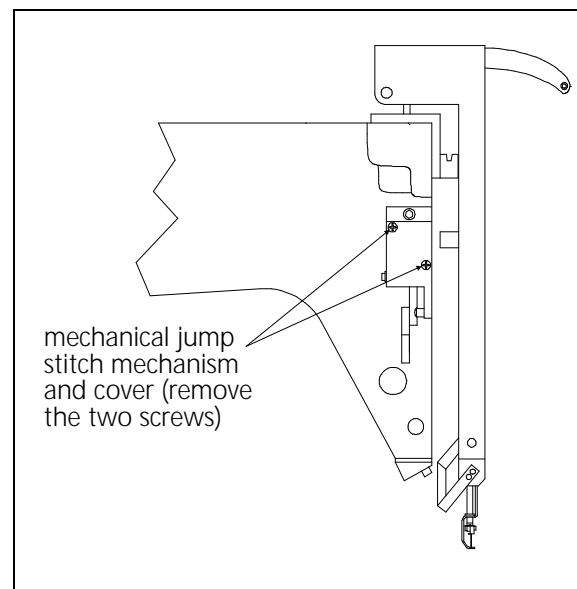

Figure 3 - 34

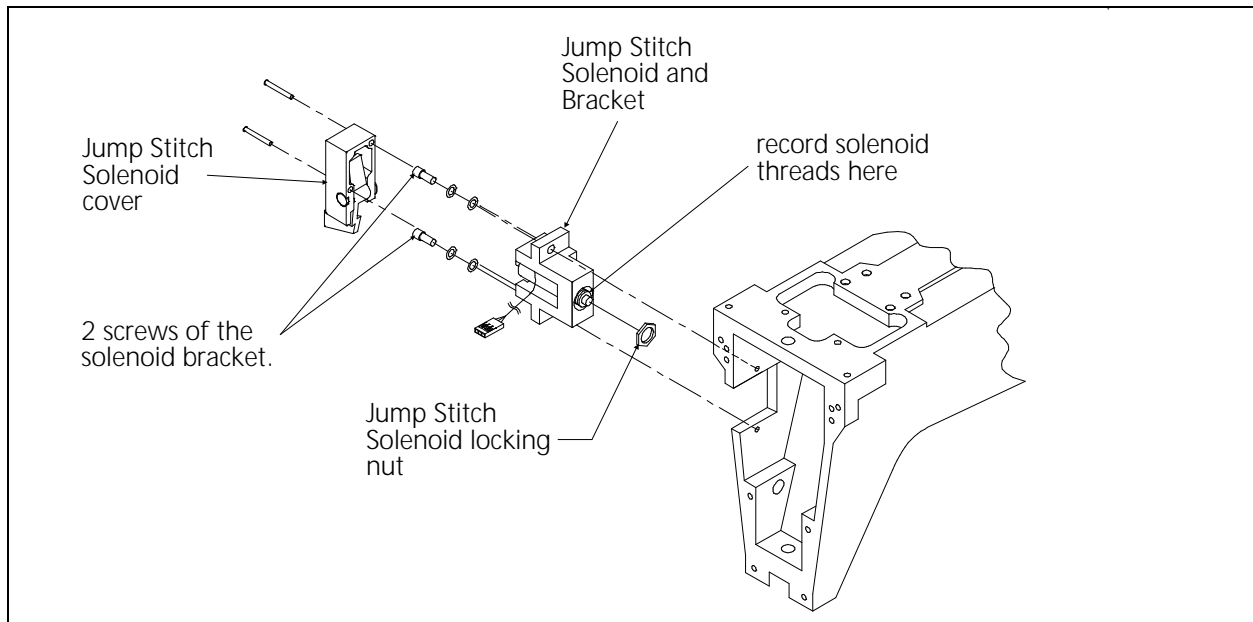

Figure 3 - 35

Note: Before you remove the solenoid from the bracket in the next step, record the number of threads of the solenoid that are showing beyond the solenoid bracket, or measure the distance that the end of the solenoid protrudes from the solenoid bracket. When the new solenoid is installed into the bracket, position the solenoid with the same number of threads showing (or the same distance) that you recorded in this step.

4. Loosen the locking nut on the solenoid, then rotate the bracket off the solenoid.
5. Reinstall the new solenoid by reversing the steps of the previous procedure. Adjust the position of the new solenoid into the solenoid bracket by using the "thread counts" or measurement you obtained (see previous Note).

Note: During installation the solenoid must be adjusted properly. If you did not adhere to the previous NOTE, or if for another reason, the adjustment for the solenoid is not correct, refer to the Jump Stitch Solenoid Adjustment procedure in Section 2 of this manual.

6. Position the solenoid bracket back in the embroidery head against the mechanical stop.
7. Rotate the Z shaft clockwise with the hex wrench in the left end of the shaft to move the heads through at least one revolution to check that no mechanical interference occurs with the jump stitch solenoid mechanism.
8. Reattach the mechanical jump stitch mechanism and cover to the jump stitch bracket using the screws removed earlier.

Color Change PCB Replacement

To access the inside of color change housing to work on the color change or grabber sections, you must remove the work shelf and come into the housing from the top. You may also remove the color change housing end covers, but do not remove the front plate.



CAUTION! Since there are motor mounting brackets attached to the color change housing front plate, **DO NOT** remove the color change housing front plate!

1. Move the computer monitor to the top of the logic control box.
2. Remove the the screws holding the work shelf and lift it off the frame to gain access to the inside of the the color change housing from the top.
3. Remove the screws holding the right end cover of the color change box; and remove the end cover.

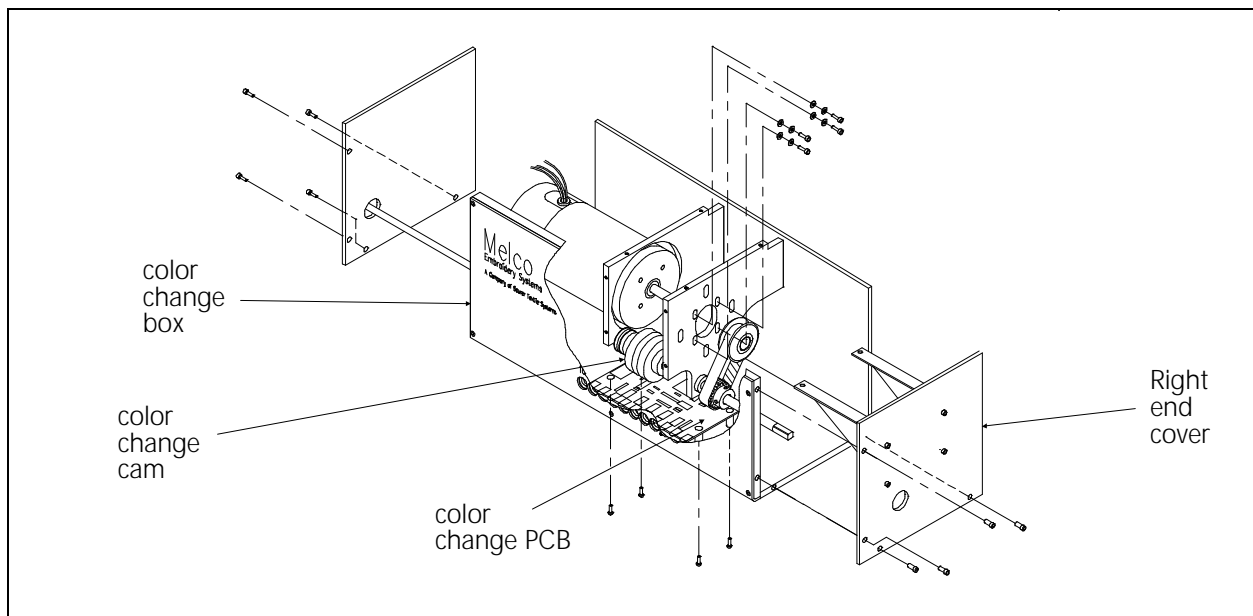

Figure 3 - 36

4. Disconnect the color change harness from the color change PCB.
5. Remove the 4 screws from the bottom of the color change box that hold the color change PCB.
6. Rotate the color change cam slightly to move the color change index tab out of the single photo sensor on the color change PCB.

7. Carefully slide the color change PCB back to clear the other 5 photo sensors from the color position indicator strip, then slide the PCB out the right side of the color change box.
8. Refer to the previous steps in reverse order to install a new color change PCB.

Note: When the color change PCB is replaced, ensure the photo sensors on the PCB are not touching the color change indicator nor the color change index tab before tightening the PCB screws.

Color Change Motor and Belt Replacement

To access the inside of color change housing to work on the color change or grabber sections, you must remove the work shelf and come into the housing from the top. You may also remove the color change housing end covers, but do not remove the front plate.



CAUTION! Since there are motor mounting brackets attached to the color change housing front plate, DO NOT remove the color change housing front plate!

1. Move the computer monitor and keyboard from the work shelf to the top of the logic control box.
2. Remove the the screws holding the work shelf and lift it off the frame to gain access to the inside of the the color change housing from the top.
3. Remove the screws holding both the left and right end covers of the color change box; and remove the end covers.

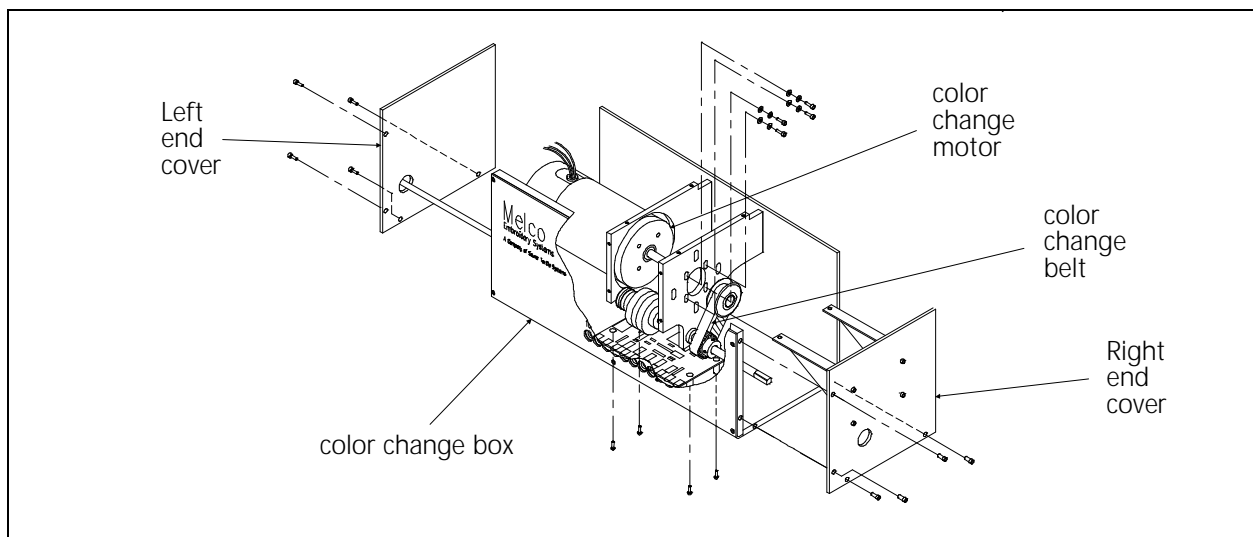

Figure 3 - 37

4. If replacing the belt only, perform the #4 sub-steps and disregard the remainder of this procedure. If replacing the motor, disregard the #4 sub-steps and complete the remaining steps of this procedure.
 - a) Loosen, but do not remove the color change motor mounting screws.
 - b) Slide the belt off the motor pulley and around the end of the color change shaft.
 - c) Install the belt in reverse order of the previous step.
 - d) Refer to the color change motor belt tensioning procedure in Section 2 of this manual.
5. If replacing the motor, make note of the harness wiring orientations, then disconnect the electrical connections to the motor and encoder.
6. Remove the color change motor mounting screws and remove the belt.
7. The motor is now loose and may be removed.
8. Note the position of the motor drive pulley, then loosen the pulley set screws and remove the motor drive pulley.
9. Position the drive pulley in the same location on the shaft of the new motor as you noted in the previous step and tighten the set screws.
10. Reverse the preceding steps to replace the motor, orienting the harness wiring associated with the motor at the locations as noted in the removal step.
11. Refer to the color change motor belt tensioning procedure in Section 2 of this manual for tensioning the belt properly.

Grabber Motor and Belt Replacement

To access the inside of color change housing to work on the color change or grabber sections, you must remove the work shelf and come into the housing from the top. You may also remove the color change housing end covers, but do not remove the front plate.



CAUTION! Since there are motor mounting brackets attached to the color change housing front plate, **DO NOT** remove the color change housing front plate!

1. Move the computer monitor to the top of the logic control box.
2. Remove the the screws holding the work shelf and lift it off the frame to gain access to the inside of the the color change housing from the top.

3. Remove the screws holding both the left and right end covers of the color change box; and remove the end covers.

Grabber Motor ONLY

If replacing the motor only, perform the following steps and disregard the belt replacement steps. If replacing the belt only, disregard these steps and refer to the Grabber Belt ONLY steps of this procedure.

4. Make note of the harness wiring orientations, then disconnect the electrical connections to the motor and encoder.

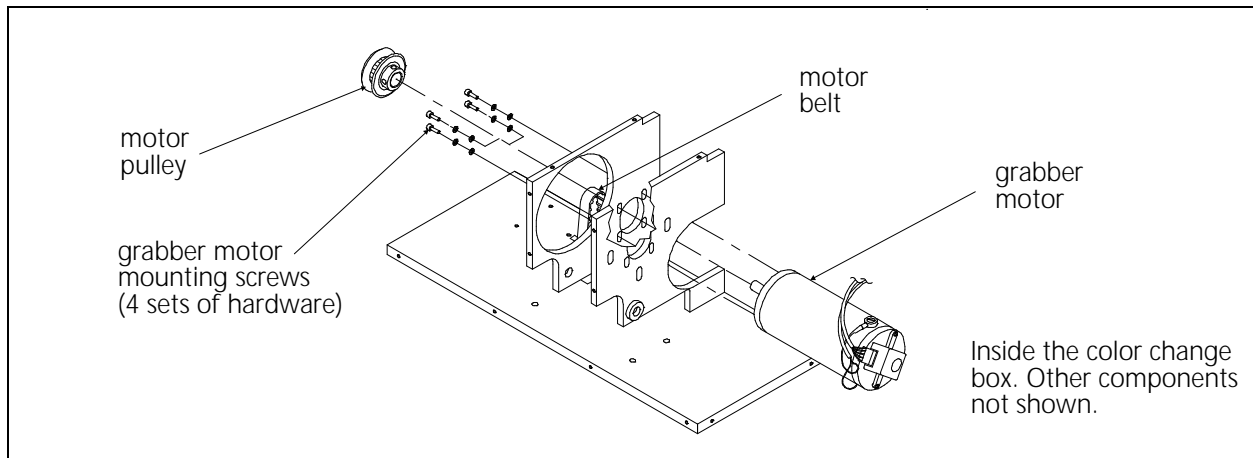

Figure 3 - 38

5. Remove the grabber motor mounting screws and slide the belt off the motor pulley.
6. The motor is now loose and may be removed.
7. Note the position of the motor drive pulley, then loosen the pulley set screws and remove the motor drive pulley.
8. Position the drive pulley in the same location on the shaft of the new motor as you noted in the previous step and tighten the set screws.
9. Reverse the preceding steps to replace the motor, orienting the harness wiring associated with the motor at the locations as noted in the removal step.
10. Refer to the grabber motor belt tensioning procedure in Section 2 of this manual.

Grabber Belt ONLY

If replacing the belt only, perform the following steps and disregard the motor replacement steps. If replacing the motor only, disregard these steps and refer to the Grabber Motor ONLY steps of this procedure.

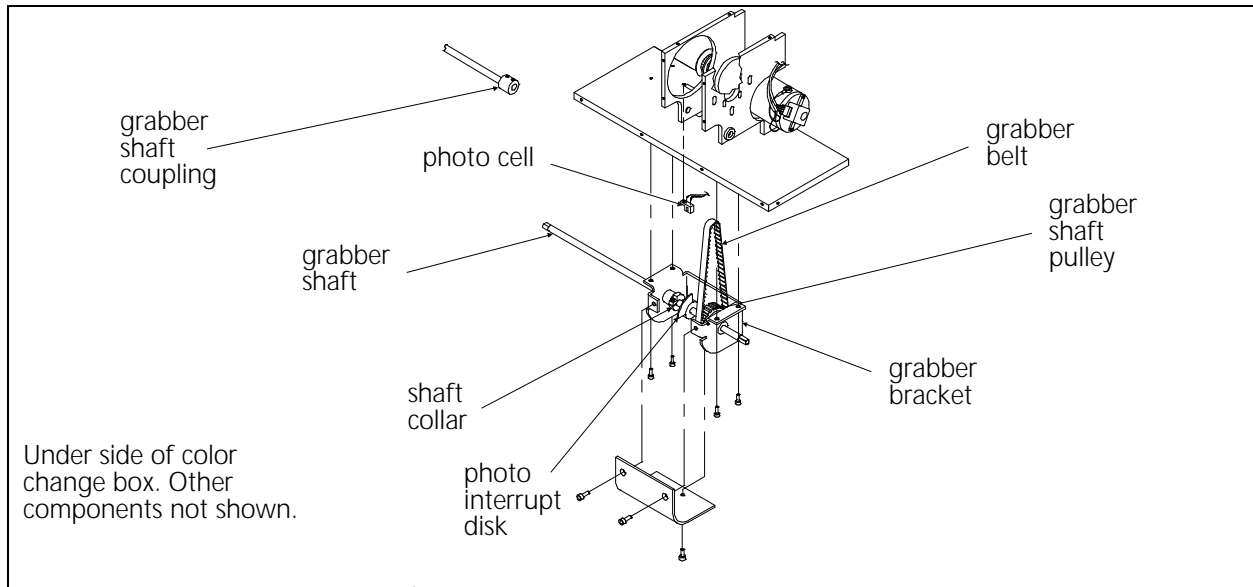

Figure 3 - 39

11. Loosen, but do not remove the grabber motor mounting screws.
12. Slide the belt off the motor pulley
13. Loosen the grabber shaft belt pulley, the photo interrupter disc, and the shaft collar to the left of the disc. Rotate the photo interrupt disc out of the photo cell above it.
14. Loosen the grabber shaft coupling between the #1 head and the color change box.
15. Slide the grabber shaft out of the coupling, then slide the shaft out of the belt pulley.
16. Slip the belt around the grabber bracket.
17. Install the new belt in reverse order of the previous steps.
18. Refer to the Grabber Motor Belt Tensioning procedure and the Grabber Set Up And Adjustment procedure in Section 2 of this manual.

Grabber Blade Replacement

1. Rotate the grabber assembly until the mounting screw shows in the slot on the back of the grabber housing.
2. Remove the mounting screw and pull out the old, damaged, or broken grabber blade.

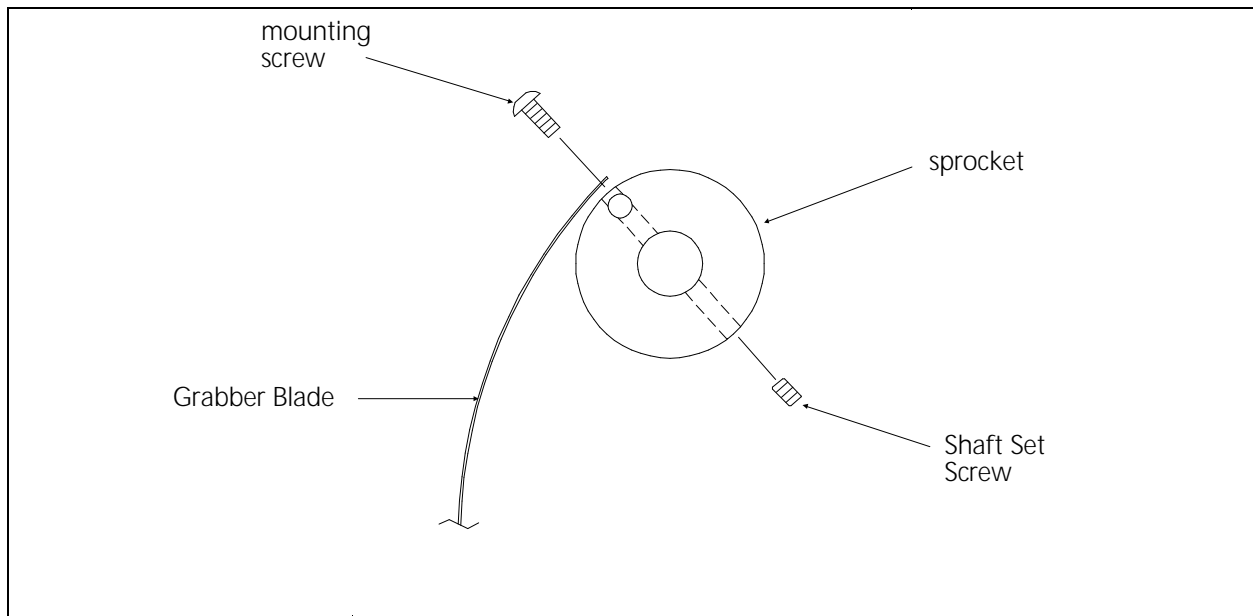

Figure 3 - 40

3. With the etched side of the grabber blade facing up, slide the new grabber blade through the Velcro wiper and lower guide; and into the grabber housing.
4. Continue to slide the blade into the housing and allow it to form around the sprocket until the hole in the blade lines up with the mounting hole.
5. Install the mounting screw while pulling out gently on the blade.
6. Tighten the mounting screw.
7. Refer to the Grabber Blade Adjustment procedure in Section 2 of this manual.

Grabber Replacement

Each grabber assembly is attached to the embroidery head arm by two screws, as well as being "locked" to the grabber drive shaft. The grabber drive shaft is comprised of six individual sections that are associated with two grabber assemblies each. The following procedure is typical for removing any of the six pairs of grabber assemblies.



1. Turn the power OFF and disconnect the power cord from the power source.

WARNING! Failure to fully disconnect the power source may result in injury to the technician or other personnel and may damage the equipment!

2. Isolate which grabber assembly is defective and loosen the shaft couplings on either side, referring to Figure 3-41. Slide the couplings back onto the "non-removed" shaft ends.

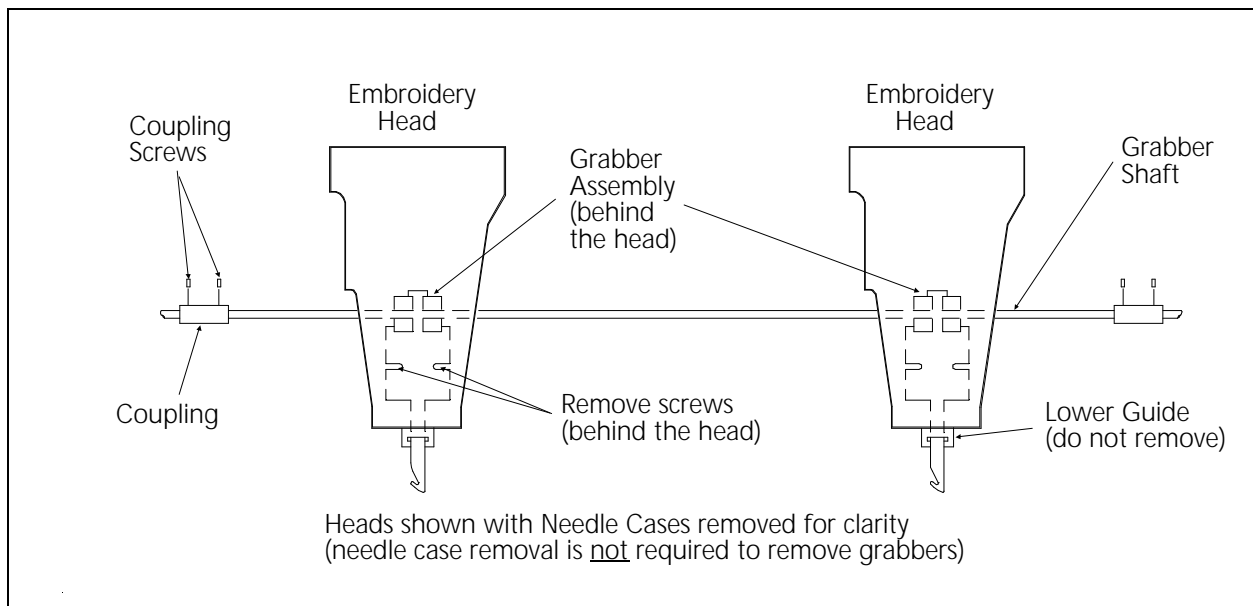

Figure 3 - 41

3. Turn the shaft clockwise by hand to fully retract the grabber blades. The blades should pull free of the lower guide blocks.
4. Remove the four screws holding the two grabber assemblies to the embroidery head arms.
5. Remove the shaft with both grabber assemblies still attached.
6. On the defective grabber assembly, pull the grabber blade outward until the set screw holding the assembly to the shaft is visible (see Figure 3-40).

7. Loosen the set screw and slide the defective grabber assembly off the shaft.
8. Slide the replacement grabber assembly onto the shaft, making certain it is oriented the same way as the other assembly.
9. Pull the grabber blade outward to reveal the set screw hole and align the hole over the "flat" portion of the shaft. Insert the set screw and "snug" it down, but do not fully tighten.
10. Set the shaft and grabber assemblies into place behind the embroidery head arms. Make sure the grabber blades are inserted and aligned in the lower guides.
11. Position the "non-replaced" grabber over its mounting holes and insert the two mounting screws.
12. Gently slide the new grabber back and forth until it is correctly aligned with its mounting holes and insert its screws as well.
13. Turn the grabber shaft clockwise until the grabber blades are full extended and the set screw hole is revealed. Tighten the set screw.
14. Align the "flat" portions at both ends of the shaft with the flat portions of the neighboring shafts. Re-attach both couplings, making certain that all 12 grabber blades are extending the same distance through the lower guides. Tighten the coupling set screws.
15. Turn the machine power ON.
16. Go to the Thread Grabber dialog box and select Start Test to check that all grabbers are working properly.
17. If the grabber blades do not seem to be properly aligned, refer to the Grabber Setup And Adjustments procedure in Section 2 of this manual.

Grabber Disassembly

Although it is easier to replace the grabber as a complete assembly, the following procedure will show how to disassemble the grabber in order to replace individual components.

1. Remove the self-tapping screw that holds the two grabber housing halves together at the top (see Figure 3-42).

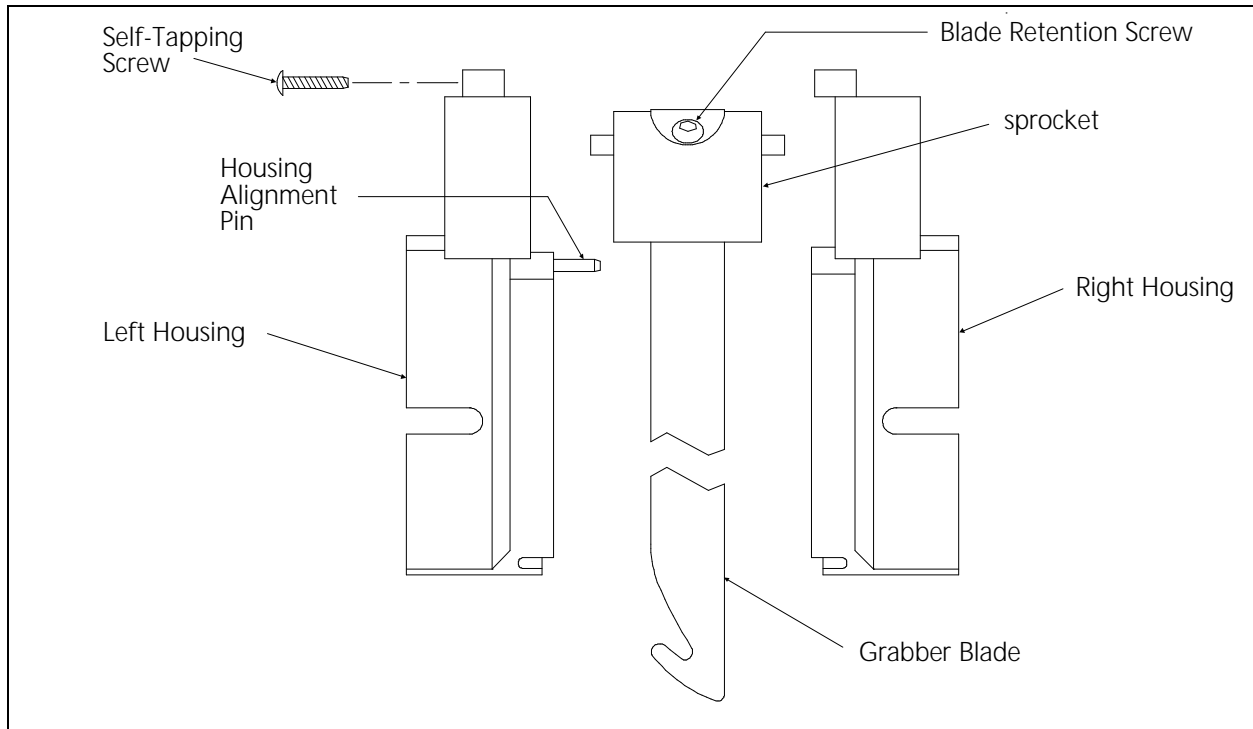

Figure 3 - 42

2. Grasp the grabber housing in both hands and gently but firmly rock the two halves back and forth until the two pieces begin to separate.
3. Pull the two halves apart, being careful not to drop any of the internal pieces.
4. Replace any broken or damaged parts as required.
5. Gently press the assembly back together, using care to guide the grabber blade inside the housing slots and the alignment pin into its associated hole.
6. Install the self-tapping screw at the top of the two housing pieces.
7. The grabber blade should extend and retract smoothly without any binding or rough movement. Refer to the Grabber Setup And Adjustments procedure in Section 2 of this manual.

Movable Knife

1. Remove the 2 screws holding the needle plate. Remove the needle plate.
2. Remove the four screws holding the bed cover. Remove the cover.
3. Lift the forward end of the B connecting link from the pin on the movable knife drive arm.
4. Push the movable knife all the way back until it stops.
5. Loosen the flat head phillips screw holding the movable knife to the top of the knife drive arm.

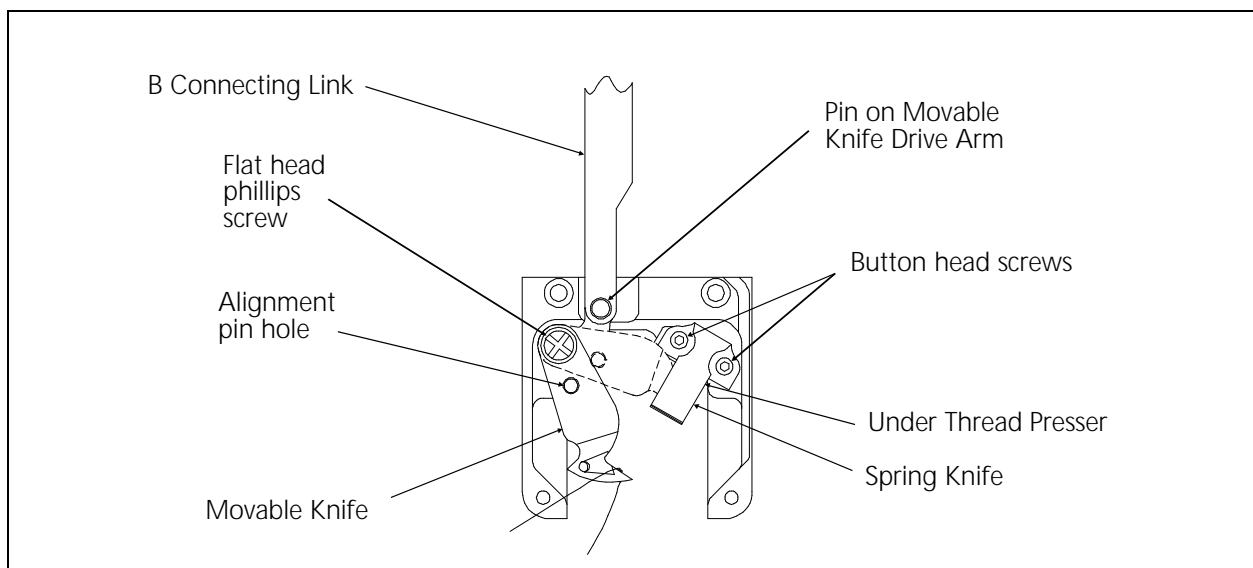

Figure 3 - 43



6. Rotate the movable knife out of the spring knife, then remove the flat head phillips screw and the movable knife.
7. Place the new movable knife on the top of the knife drive arm, positioning the alignment hole in the knife over the alignment pin in the arm.
8. Install the flat head phillips screw and snug it with your fingers.



9. Rotate the knife and arm clockwise until the backside of the knife is resting against the left side of the needle plate mounting bracket, then tighten the flat head phillips screw.
10. Check that the spring knife is contacting the new movable knife evenly across the surface as detailed in Section 2 of this manual.

Movable Knife Drive Arm

1. Remove the 2 screws holding the needle plate. Remove the needle plate.
2. Remove the four screws holding the bed cover. Remove the bed cover.
3. Lift the forward end of the connecting link from the pin on the movable knife drive arm
4. Remove the small pan head screw and fixing clip from the bottom of the needle plate bracket (refer to Figure 3-44).

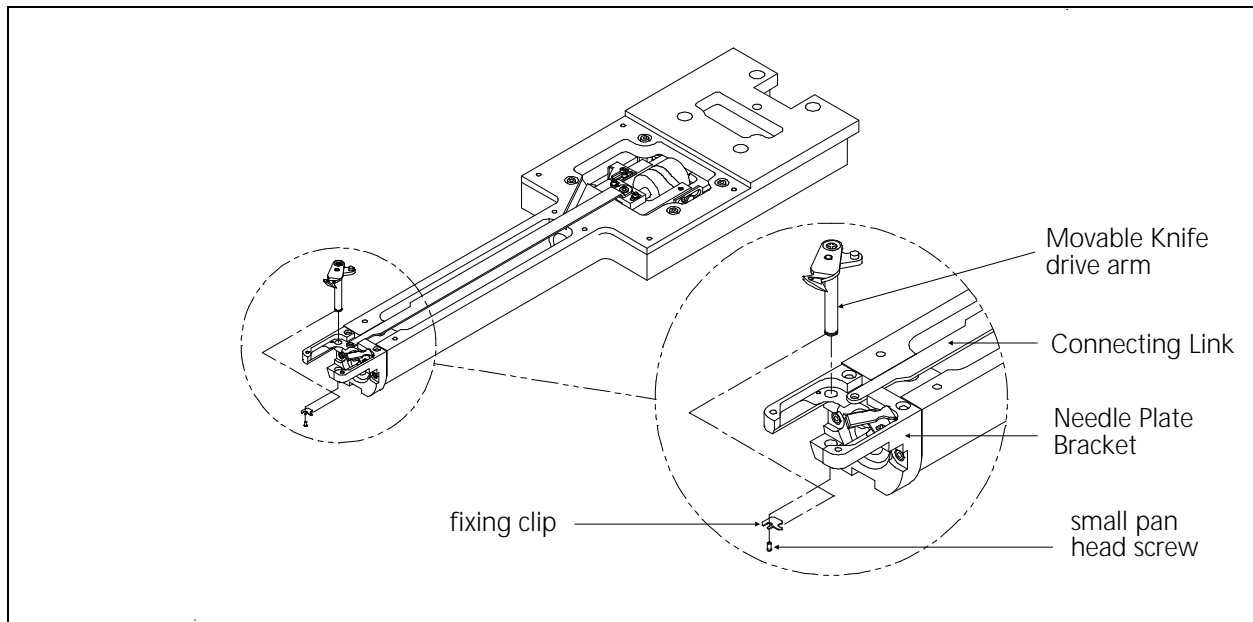

Figure 3 - 44

5. The clip is held into a slot in the arm shaft by the screw and the combination of the two holds the arm shaft in place. Once the clip is removed, the arm shaft is free to be removed out of the top of the needle plate bracket.
6. To install the new arm shaft, reverse the preceding steps.

Spring Knife Replacement

1. Remove the 2 screws holding the needle plate. Remove the needle plate.
2. Remove the four screws holding the bed cover. Remove the bed cover.
3. Lift the forward end of the B connecting link from the pin on the movable knife drive arm.
4. Rotate the movable knife clockwise to remove it from under the spring knife and under thread presser (refer to Figure 3-45).

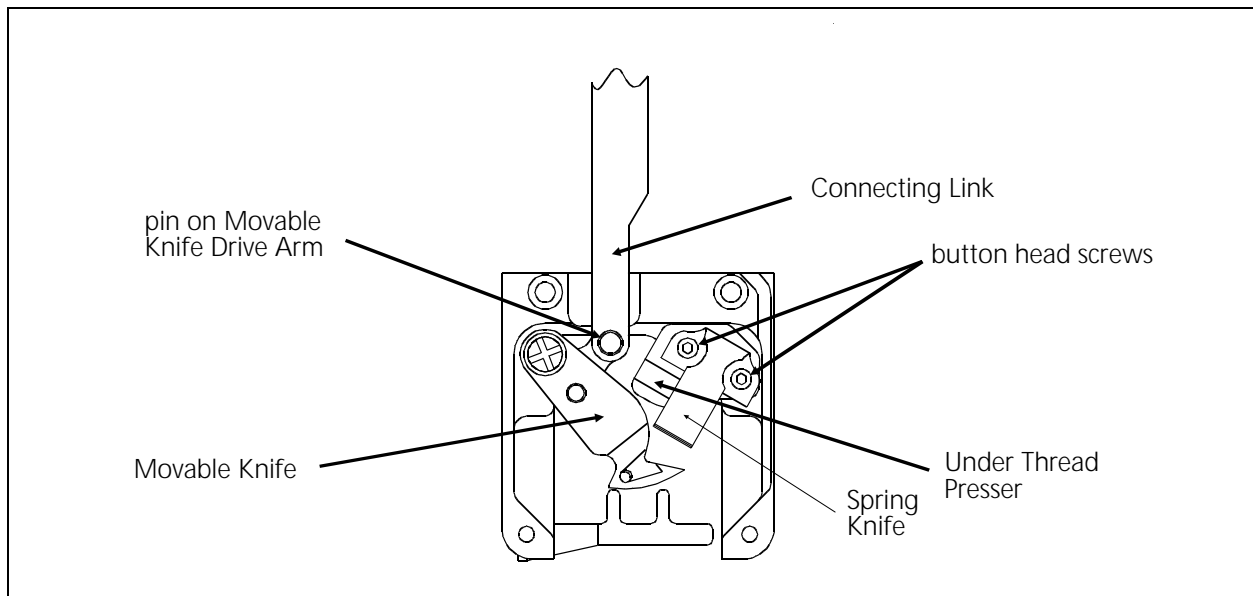

Figure 3 - 45

5. Remove the two button head screws from the top of the spring knife.
6. Remove the spring knife, under thread presser, and/or spacer. (A spacer may be placed under one of the screws for leveling the spring knife at initial installation.)
7. Replace required new parts and install the 2 button head screws.
8. Insure the under thread presser is in the proper position and not interfering with the knife drive arm or the rotating hook.



After replacing a spring knife, it is advised to operate the TRIM command several times to allow the spring knife to "seat" with the movable knife. If the movable and spring knives do not align properly for a successful trim replace the spring knife again. If the alignment is still not proper you may correct the alignment by inserting a thin shim between the spring knife and the under thread presser at the button head screw on the side that needs to be raised.

Picker Replacement

To replace a defective picker, refer to Figure 3-46 and the following steps:

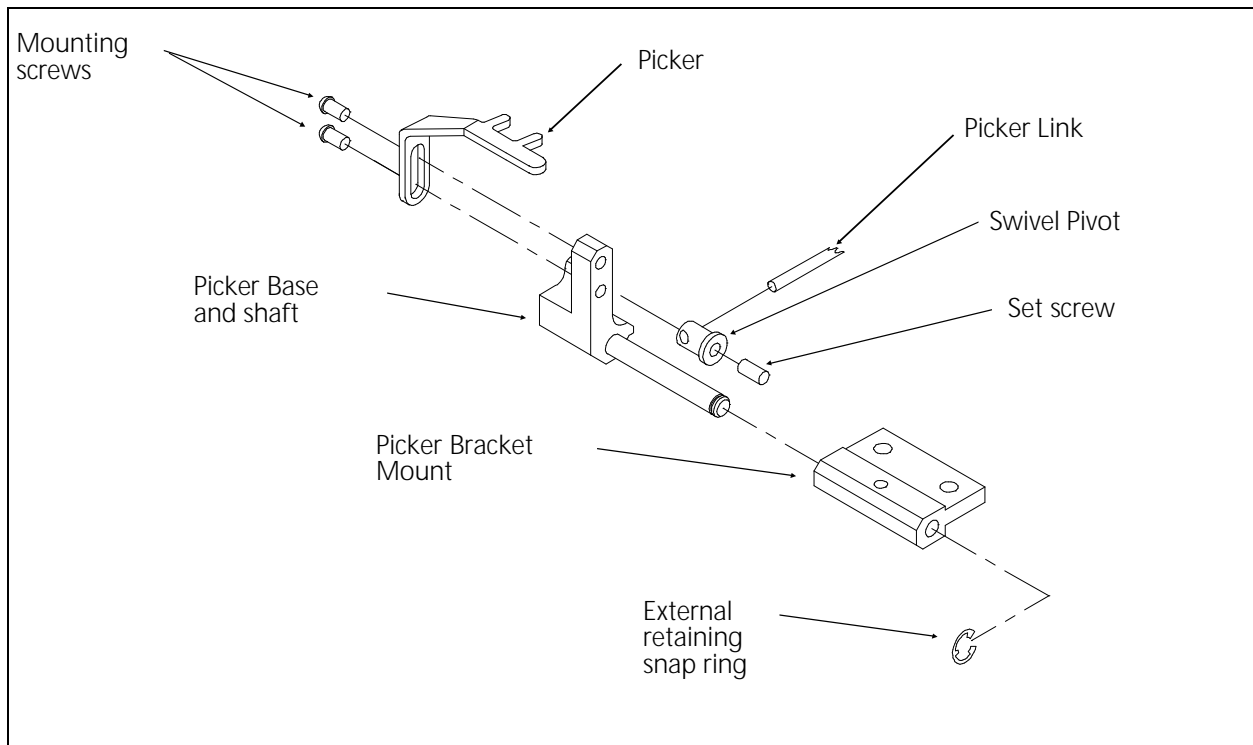

Figure 3 - 46

1. Remove the two mounting screws and defective picker.
2. Install a new picker and attach it to the picker base with the removed screws.
3. Refer to the picker adjustment procedures in Section 2 of this manual.

If other parts in the picker assembly need to be replaced refer to Figure 3-46 and the following steps:

4. Remove the 2 screws holding the needle plate. Remove the needle plate.
5. Disconnect the picker link from the picker base by loosening the set screw inside the swivel pivot of the picker base.
6. Remove the external retaining ring at the right end of the picker base shaft.
7. Slide the picker assembly out of the picker bracket mount.

When re-attaching the picker link to the picker assembly, refer to the picker adjustment procedures in Section 2 of this manual.

UTC Replacement

To remove the UTC assembly refer to the steps that follow:

1. With the machine in the head up position, turn the power switch OFF.
2. Remove the table top insert from the machine to access the Hook and UTC area.
3. Remove the needle plate, front bed cover, and right side rotary hook cover to access the UTC assembly including the sensor cable and connection to the harnessing in the bed.
4. Disconnect the sensor cable from the harness inside the bed and remove the cable from around the needle plate support bracket (see Figure 3-47).

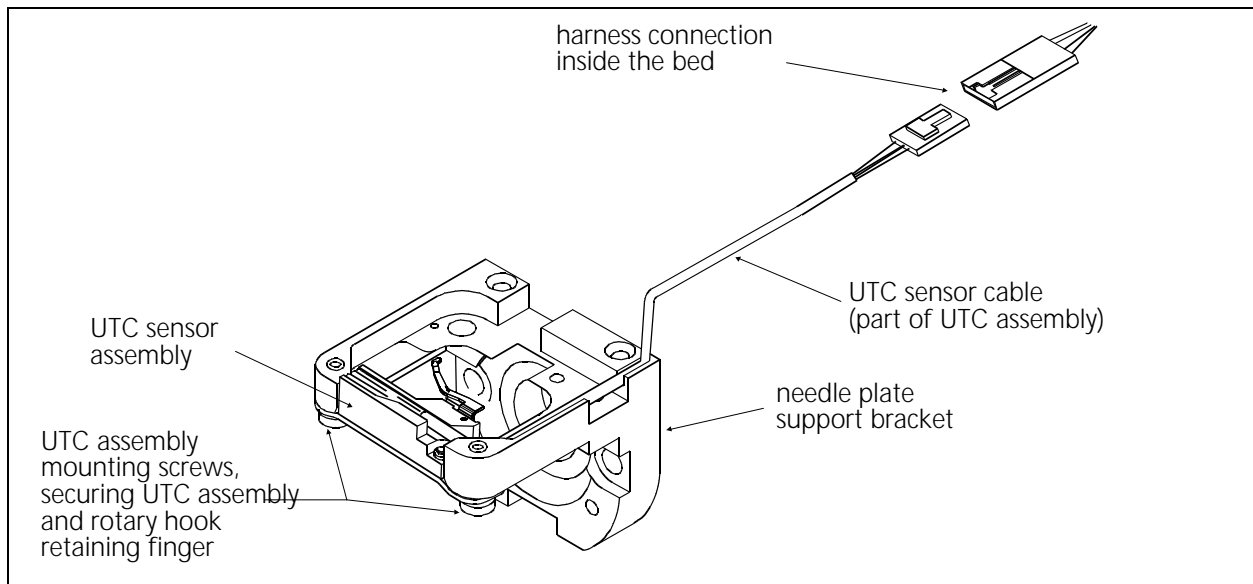

Figure 3 - 47

5. Remove the 2 UTC assembly mounting screws that hold the UTC assembly and rotary hook retaining finger to the bottom of the needle plate support bracket (see Figure 3-47).

To attach the UTC assembly, refer to the steps that follow.

6. Connect the sensor cable from the new UTC assembly to the harness inside the bed as indicated in Figure 3-47.
7. Rotate the rotary hook inner basket to position the notch to the top so the retaining finger tab will fit into the notch properly when the UTC assembly is attached.

- Place the UTC assembly under the needle plate support bracket as shown in Figure 3-48 and install the 2 UTC assembly mounting screws.

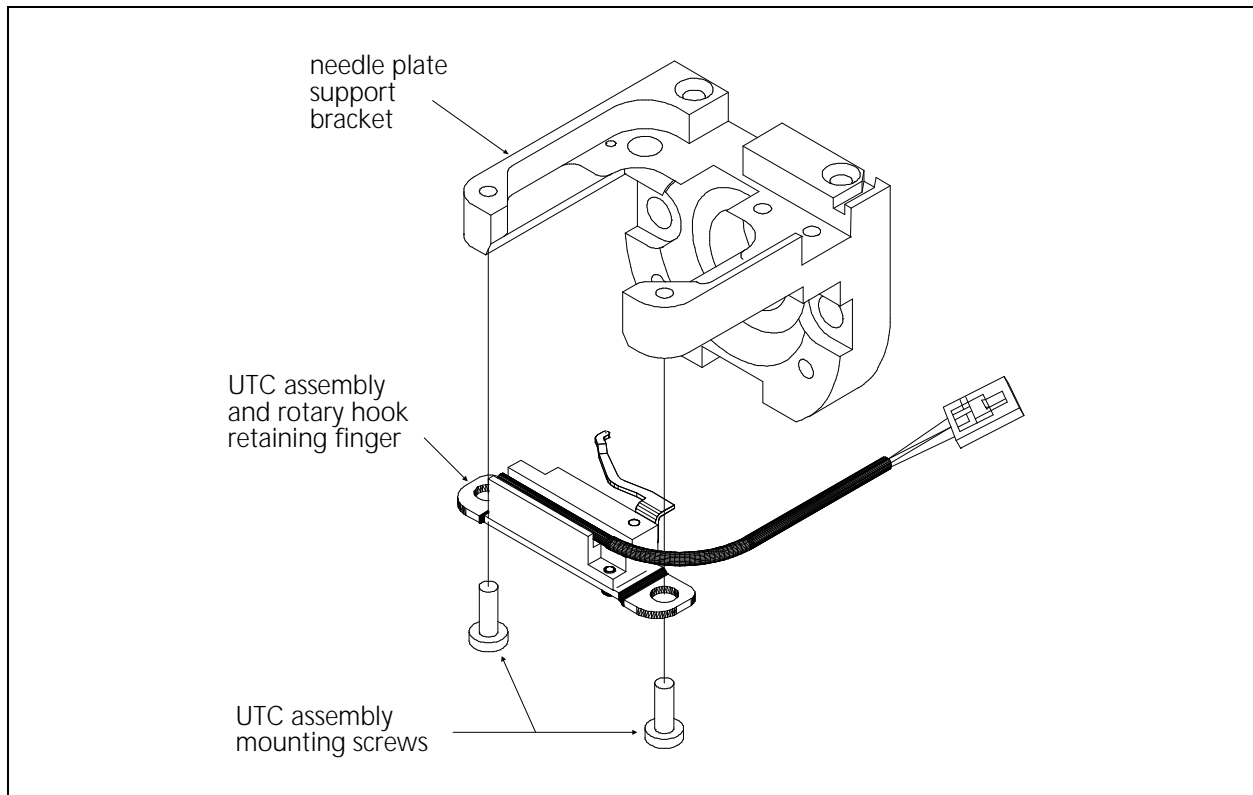

Figure 3 - 48

- Perform the UTC adjustments in Chapter 2 of this manual.

INDEX

<table border="0" style="width: 100%; border-collapse: collapse;"> <tr> <td style="text-align: center;">#</td> <td style="border-top: 1px solid black; border-bottom: 1px solid black;"></td> </tr> <tr> <td>+5 Volt Logic Voltage adjustment</td> <td style="text-align: right;">2-7</td> </tr> <tr> <td style="text-align: center;">A</td> <td style="border-top: 1px solid black; border-bottom: 1px solid black;"></td> </tr> <tr> <td>Arm and Bed Assembly</td> <td style="text-align: right;">3-21</td> </tr> <tr> <td style="text-align: center;">B</td> <td style="border-top: 1px solid black; border-bottom: 1px solid black;"></td> </tr> <tr> <td>Belt Replacement</td> <td></td> </tr> <tr> <td> Color Change</td> <td style="text-align: right;">3-39</td> </tr> <tr> <td> grabber motor</td> <td style="text-align: right;">3-40</td> </tr> <tr> <td> X and Y drive</td> <td style="text-align: right;">3-11</td> </tr> <tr> <td> X motor</td> <td style="text-align: right;">3-13</td> </tr> <tr> <td> Y motor</td> <td style="text-align: right;">3-15</td> </tr> <tr> <td>Belt Tension Gauge</td> <td></td> </tr> <tr> <td> how to use</td> <td style="text-align: right;">2-1</td> </tr> <tr> <td>Belt Tensions</td> <td></td> </tr> <tr> <td> color change motor</td> <td style="text-align: right;">2-24</td> </tr> <tr> <td> X and Y drive</td> <td style="text-align: right;">2-2</td> </tr> <tr> <td> X and Y motor</td> <td style="text-align: right;">2-4</td> </tr> <tr> <td style="text-align: center;">C</td> <td style="border-top: 1px solid black; border-bottom: 1px solid black;"></td> </tr> <tr> <td>Cap Frame</td> <td></td> </tr> <tr> <td> setting limits</td> <td style="text-align: right;">2-28, 2-30</td> </tr> <tr> <td>Center Index</td> <td></td> </tr> <tr> <td> setting</td> <td style="text-align: right;">2-27</td> </tr> <tr> <td>Check Spring</td> <td></td> </tr> <tr> <td> adjustment</td> <td style="text-align: right;">2-16</td> </tr> <tr> <td> replacement</td> <td style="text-align: right;">3-25</td> </tr> <tr> <td>Color Change Link Bar</td> <td></td> </tr> <tr> <td> adjustment</td> <td style="text-align: right;">2-24</td> </tr> <tr> <td>Color Change Motor</td> <td></td> </tr> <tr> <td> replacement</td> <td style="text-align: right;">3-39</td> </tr> <tr> <td>Color Change PCB</td> <td></td> </tr> <tr> <td> replacement</td> <td style="text-align: right;">3-38</td> </tr> <tr> <td>Computer Keyboard</td> <td></td> </tr> <tr> <td> replacement</td> <td style="text-align: right;">3-6</td> </tr> <tr> <td>Conventions Used In Manual</td> <td style="text-align: right;">1-1</td> </tr> <tr> <td>Covers</td> <td></td> </tr> <tr> <td> removal</td> <td style="text-align: right;">3-8</td> </tr> <tr> <td>Cross Roller Bearing</td> <td></td> </tr> <tr> <td> centering</td> <td style="text-align: right;">2-17</td> </tr> <tr> <td> replacement</td> <td style="text-align: right;">3-34</td> </tr> <tr> <td style="text-align: center;">D</td> <td style="border-top: 1px solid black; border-bottom: 1px solid black;"></td> </tr> <tr> <td>Disk Drive</td> <td></td> </tr> <tr> <td> replacement</td> <td style="text-align: right;">3-7</td> </tr> <tr> <td>Drive Belt Tensions</td> <td style="text-align: right;">2-1</td> </tr> <tr> <td style="text-align: center;">E</td> <td style="border-top: 1px solid black; border-bottom: 1px solid black;"></td> </tr> <tr> <td>Embroidery Heads</td> <td style="text-align: right;">2-9, 3-21</td> </tr> <tr> <td>Emergency Switch</td> <td></td> </tr> <tr> <td> replacement</td> <td style="text-align: right;">3-10</td> </tr> </table>	#		+5 Volt Logic Voltage adjustment	2-7	A		Arm and Bed Assembly	3-21	B		Belt Replacement		Color Change	3-39	grabber motor	3-40	X and Y drive	3-11	X motor	3-13	Y motor	3-15	Belt Tension Gauge		how to use	2-1	Belt Tensions		color change motor	2-24	X and Y drive	2-2	X and Y motor	2-4	C		Cap Frame		setting limits	2-28, 2-30	Center Index		setting	2-27	Check Spring		adjustment	2-16	replacement	3-25	Color Change Link Bar		adjustment	2-24	Color Change Motor		replacement	3-39	Color Change PCB		replacement	3-38	Computer Keyboard		replacement	3-6	Conventions Used In Manual	1-1	Covers		removal	3-8	Cross Roller Bearing		centering	2-17	replacement	3-34	D		Disk Drive		replacement	3-7	Drive Belt Tensions	2-1	E		Embroidery Heads	2-9, 3-21	Emergency Switch		replacement	3-10	<table border="0" style="width: 100%; border-collapse: collapse;"> <tr> <td style="text-align: center;">F</td> <td style="border-top: 1px solid black; border-bottom: 1px solid black;"></td> </tr> <tr> <td>Flats Limits</td> <td></td> </tr> <tr> <td> setting</td> <td style="text-align: right;">2-32</td> </tr> <tr> <td style="text-align: center;">G</td> <td style="border-top: 1px solid black; border-bottom: 1px solid black;"></td> </tr> <tr> <td>Grabber</td> <td></td> </tr> <tr> <td> disassembly</td> <td style="text-align: right;">3-46</td> </tr> <tr> <td>Grabber Assembly</td> <td></td> </tr> <tr> <td> replacement</td> <td style="text-align: right;">3-44</td> </tr> <tr> <td> setup and adjustments</td> <td style="text-align: right;">2-46</td> </tr> <tr> <td>Grabber Blade</td> <td></td> </tr> <tr> <td> replacement</td> <td style="text-align: right;">3-43</td> </tr> <tr> <td> setup and adjustments</td> <td style="text-align: right;">2-46</td> </tr> <tr> <td>Grabber Motor</td> <td></td> </tr> <tr> <td> replacement</td> <td style="text-align: right;">3-40</td> </tr> <tr> <td style="text-align: center;">H</td> <td style="border-top: 1px solid black; border-bottom: 1px solid black;"></td> </tr> <tr> <td>Home Position</td> <td></td> </tr> <tr> <td> movable knife</td> <td style="text-align: right;">2-39</td> </tr> <tr> <td style="text-align: center;">J</td> <td style="border-top: 1px solid black; border-bottom: 1px solid black;"></td> </tr> <tr> <td>Jump Stitch Solenoid</td> <td></td> </tr> <tr> <td> adjustment</td> <td style="text-align: right;">2-22</td> </tr> <tr> <td> replacement</td> <td style="text-align: right;">3-36</td> </tr> <tr> <td style="text-align: center;">K</td> <td style="border-top: 1px solid black; border-bottom: 1px solid black;"></td> </tr> <tr> <td>Keypad</td> <td></td> </tr> <tr> <td> replacement</td> <td style="text-align: right;">3-9</td> </tr> <tr> <td style="text-align: center;">L</td> <td style="border-top: 1px solid black; border-bottom: 1px solid black;"></td> </tr> <tr> <td>Logic Control Box</td> <td></td> </tr> <tr> <td> cover removal</td> <td style="text-align: right;">3-1</td> </tr> <tr> <td>Low Voltage Driver PCB</td> <td></td> </tr> <tr> <td> replacement</td> <td style="text-align: right;">3-5</td> </tr> <tr> <td>Lower Rail Retainer</td> <td></td> </tr> <tr> <td> adjustment</td> <td style="text-align: right;">2-21</td> </tr> <tr> <td style="text-align: center;">M</td> <td style="border-top: 1px solid black; border-bottom: 1px solid black;"></td> </tr> <tr> <td>Maintenance Philosophy</td> <td style="text-align: right;">1-2</td> </tr> <tr> <td>Monitor</td> <td></td> </tr> <tr> <td> replacement</td> <td style="text-align: right;">3-7</td> </tr> <tr> <td>Motherboard</td> <td></td> </tr> <tr> <td> replacement</td> <td style="text-align: right;">3-3</td> </tr> <tr> <td>Motor Drive Modules</td> <td></td> </tr> <tr> <td> replacement</td> <td style="text-align: right;">3-19</td> </tr> <tr> <td> setting current limit switches</td> <td style="text-align: right;">3-20</td> </tr> <tr> <td>Motor Replacement</td> <td></td> </tr> <tr> <td> X motor</td> <td style="text-align: right;">3-13</td> </tr> <tr> <td> Y motor</td> <td style="text-align: right;">3-15</td> </tr> <tr> <td> Z motor</td> <td style="text-align: right;">3-21</td> </tr> <tr> <td>Movable Knife</td> <td style="text-align: right;">3-47</td> </tr> <tr> <td> adjustment</td> <td style="text-align: right;">2-39</td> </tr> <tr> <td>Movable Knife Drive Arm</td> <td style="text-align: right;">3-48</td> </tr> </table>	F		Flats Limits		setting	2-32	G		Grabber		disassembly	3-46	Grabber Assembly		replacement	3-44	setup and adjustments	2-46	Grabber Blade		replacement	3-43	setup and adjustments	2-46	Grabber Motor		replacement	3-40	H		Home Position		movable knife	2-39	J		Jump Stitch Solenoid		adjustment	2-22	replacement	3-36	K		Keypad		replacement	3-9	L		Logic Control Box		cover removal	3-1	Low Voltage Driver PCB		replacement	3-5	Lower Rail Retainer		adjustment	2-21	M		Maintenance Philosophy	1-2	Monitor		replacement	3-7	Motherboard		replacement	3-3	Motor Drive Modules		replacement	3-19	setting current limit switches	3-20	Motor Replacement		X motor	3-13	Y motor	3-15	Z motor	3-21	Movable Knife	3-47	adjustment	2-39	Movable Knife Drive Arm	3-48
#																																																																																																																																																																																													
+5 Volt Logic Voltage adjustment	2-7																																																																																																																																																																																												
A																																																																																																																																																																																													
Arm and Bed Assembly	3-21																																																																																																																																																																																												
B																																																																																																																																																																																													
Belt Replacement																																																																																																																																																																																													
Color Change	3-39																																																																																																																																																																																												
grabber motor	3-40																																																																																																																																																																																												
X and Y drive	3-11																																																																																																																																																																																												
X motor	3-13																																																																																																																																																																																												
Y motor	3-15																																																																																																																																																																																												
Belt Tension Gauge																																																																																																																																																																																													
how to use	2-1																																																																																																																																																																																												
Belt Tensions																																																																																																																																																																																													
color change motor	2-24																																																																																																																																																																																												
X and Y drive	2-2																																																																																																																																																																																												
X and Y motor	2-4																																																																																																																																																																																												
C																																																																																																																																																																																													
Cap Frame																																																																																																																																																																																													
setting limits	2-28, 2-30																																																																																																																																																																																												
Center Index																																																																																																																																																																																													
setting	2-27																																																																																																																																																																																												
Check Spring																																																																																																																																																																																													
adjustment	2-16																																																																																																																																																																																												
replacement	3-25																																																																																																																																																																																												
Color Change Link Bar																																																																																																																																																																																													
adjustment	2-24																																																																																																																																																																																												
Color Change Motor																																																																																																																																																																																													
replacement	3-39																																																																																																																																																																																												
Color Change PCB																																																																																																																																																																																													
replacement	3-38																																																																																																																																																																																												
Computer Keyboard																																																																																																																																																																																													
replacement	3-6																																																																																																																																																																																												
Conventions Used In Manual	1-1																																																																																																																																																																																												
Covers																																																																																																																																																																																													
removal	3-8																																																																																																																																																																																												
Cross Roller Bearing																																																																																																																																																																																													
centering	2-17																																																																																																																																																																																												
replacement	3-34																																																																																																																																																																																												
D																																																																																																																																																																																													
Disk Drive																																																																																																																																																																																													
replacement	3-7																																																																																																																																																																																												
Drive Belt Tensions	2-1																																																																																																																																																																																												
E																																																																																																																																																																																													
Embroidery Heads	2-9, 3-21																																																																																																																																																																																												
Emergency Switch																																																																																																																																																																																													
replacement	3-10																																																																																																																																																																																												
F																																																																																																																																																																																													
Flats Limits																																																																																																																																																																																													
setting	2-32																																																																																																																																																																																												
G																																																																																																																																																																																													
Grabber																																																																																																																																																																																													
disassembly	3-46																																																																																																																																																																																												
Grabber Assembly																																																																																																																																																																																													
replacement	3-44																																																																																																																																																																																												
setup and adjustments	2-46																																																																																																																																																																																												
Grabber Blade																																																																																																																																																																																													
replacement	3-43																																																																																																																																																																																												
setup and adjustments	2-46																																																																																																																																																																																												
Grabber Motor																																																																																																																																																																																													
replacement	3-40																																																																																																																																																																																												
H																																																																																																																																																																																													
Home Position																																																																																																																																																																																													
movable knife	2-39																																																																																																																																																																																												
J																																																																																																																																																																																													
Jump Stitch Solenoid																																																																																																																																																																																													
adjustment	2-22																																																																																																																																																																																												
replacement	3-36																																																																																																																																																																																												
K																																																																																																																																																																																													
Keypad																																																																																																																																																																																													
replacement	3-9																																																																																																																																																																																												
L																																																																																																																																																																																													
Logic Control Box																																																																																																																																																																																													
cover removal	3-1																																																																																																																																																																																												
Low Voltage Driver PCB																																																																																																																																																																																													
replacement	3-5																																																																																																																																																																																												
Lower Rail Retainer																																																																																																																																																																																													
adjustment	2-21																																																																																																																																																																																												
M																																																																																																																																																																																													
Maintenance Philosophy	1-2																																																																																																																																																																																												
Monitor																																																																																																																																																																																													
replacement	3-7																																																																																																																																																																																												
Motherboard																																																																																																																																																																																													
replacement	3-3																																																																																																																																																																																												
Motor Drive Modules																																																																																																																																																																																													
replacement	3-19																																																																																																																																																																																												
setting current limit switches	3-20																																																																																																																																																																																												
Motor Replacement																																																																																																																																																																																													
X motor	3-13																																																																																																																																																																																												
Y motor	3-15																																																																																																																																																																																												
Z motor	3-21																																																																																																																																																																																												
Movable Knife	3-47																																																																																																																																																																																												
adjustment	2-39																																																																																																																																																																																												
Movable Knife Drive Arm	3-48																																																																																																																																																																																												

Index

N	
Needle Bar	
replacement	3-28
Needle Case	
installation	3-33
removal	3-31
Needle Centering	2-24
P	
Panels	
removal	3-8
Picker	
finger center positioning	2-44
height/depth position	2-45
home position	2-45
replacement	3-50
Power Supply	
motor voltage	2-6
replacement	3-18
system voltage	2-6
Pre-Tensioner	
replacement	3-24
R	
Reciprocator	
assembly replacement	3-35
Retainer Plate Bearing	
adjustment	2-19
S	
Sash Frame	3-11
movement dimensions	2-32
Select Position	
adjustment	2-43
Spring Knife	
adjustment	2-35
replacement	3-49
Start/Stop Switch	
replacement	3-10
Static Electricity	1-2
grounding strap use	1-2
Switch Replacement	
Start/Stop and Emergency	3-10
Synchronizing The Heads	2-11
System Overview	
physical/functional arrangement	1-3

T	
Tensioner	
assembly replacement	3-24
individual parts replacement	3-26
Tensioner Assembly Panel	
removal	3-23
Thread Break Brush	
adjustment	2-26
Thread Break Contact Brush	
replacement	3-28
Thread Break Contact Post	
replacement	3-27
Trimmer Cam Position	
adjustment	2-41
Trimmer System	
sequence of trim events	2-33
setup and adjustments	2-34
U	
Under Thread Presser	2-37
Upright PCBs	
replacement	3-2
User Station	3-1
W	
Warranty Considerations	1-2
X	
X and Y Stop/Limit Encoder	
adjustment	2-27
Z	
Z Drive Mechanical System	2-9
Z Drive Shaft	
couplings	2-9
gear mesh	2-12
thrust bearings	2-9
Z Encoder System	
calibration	2-14
inspection	2-13